

Austrian Napoleonic Artillery 1792–1815

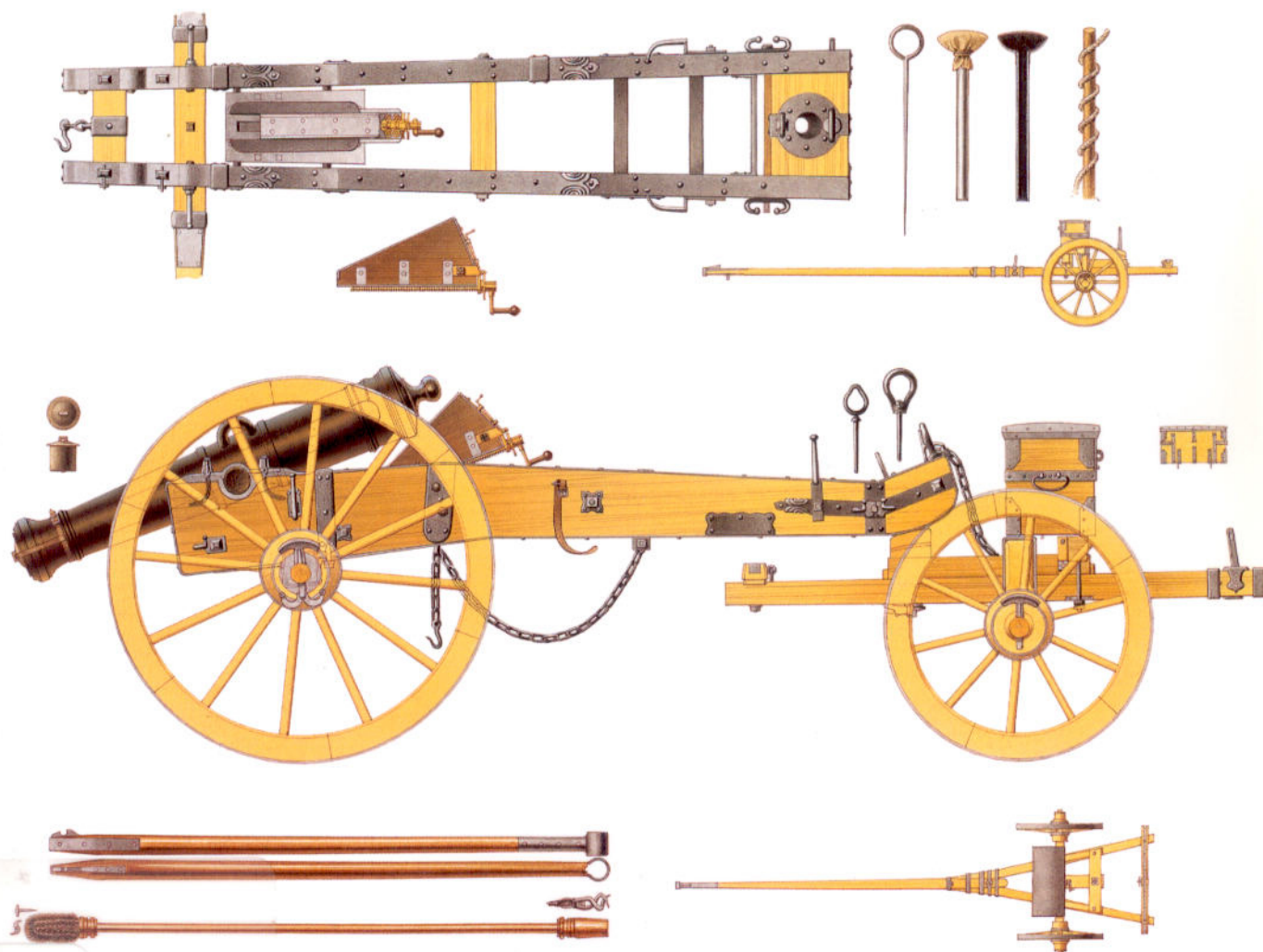



DAVID HOLLINS was born in Aberdeen, Scotland, in 1962. After graduating from University College London, he trained as a maritime solicitor and began his career in commercial shipping. He is a frequent contributor to specialist Napoleonic magazines and has written a number of books related to the Imperial Army and Archduke Charles. His previous work for Osprey includes *Men-at-Arms 299: Austrian Auxiliary Troops 1792-1816*, and *Warrior 24: Austrian Grenadiers and Infantry 1788-1816*.



BRIAN DELF began his career working in a London art studio producing artwork for advertising and commercial publications. Since 1972, he has worked as a freelance illustrator on a variety of subjects including natural history, architecture and technical cutaways. Some of his recently illustrated books have been published in over thirty countries. Brian lives and works in Oxfordshire.

CONTENTS

INTRODUCTION	3
ORGANISATION AND OPERATIONS	4
<ul style="list-style-type: none">• Overall strength• Allocation of artillery• Personnel• In battle	
EQUIPMENT	15
<ul style="list-style-type: none">• The Lichtenstein system• Gun carriages and limbers• Cavalry artillery guns• Siege and defence guns• Gun manufacture• Rockets• Ammunition• Ammunition storage• Powder• Effectiveness• Wagons and packhorses	
COLLECTIONS AND FURTHER READING	42
GLOSSARY	43
COLOUR PLATE COMMENTARY	44
INDEX	48

Austrian Napoleonic Artillery 1792–1815

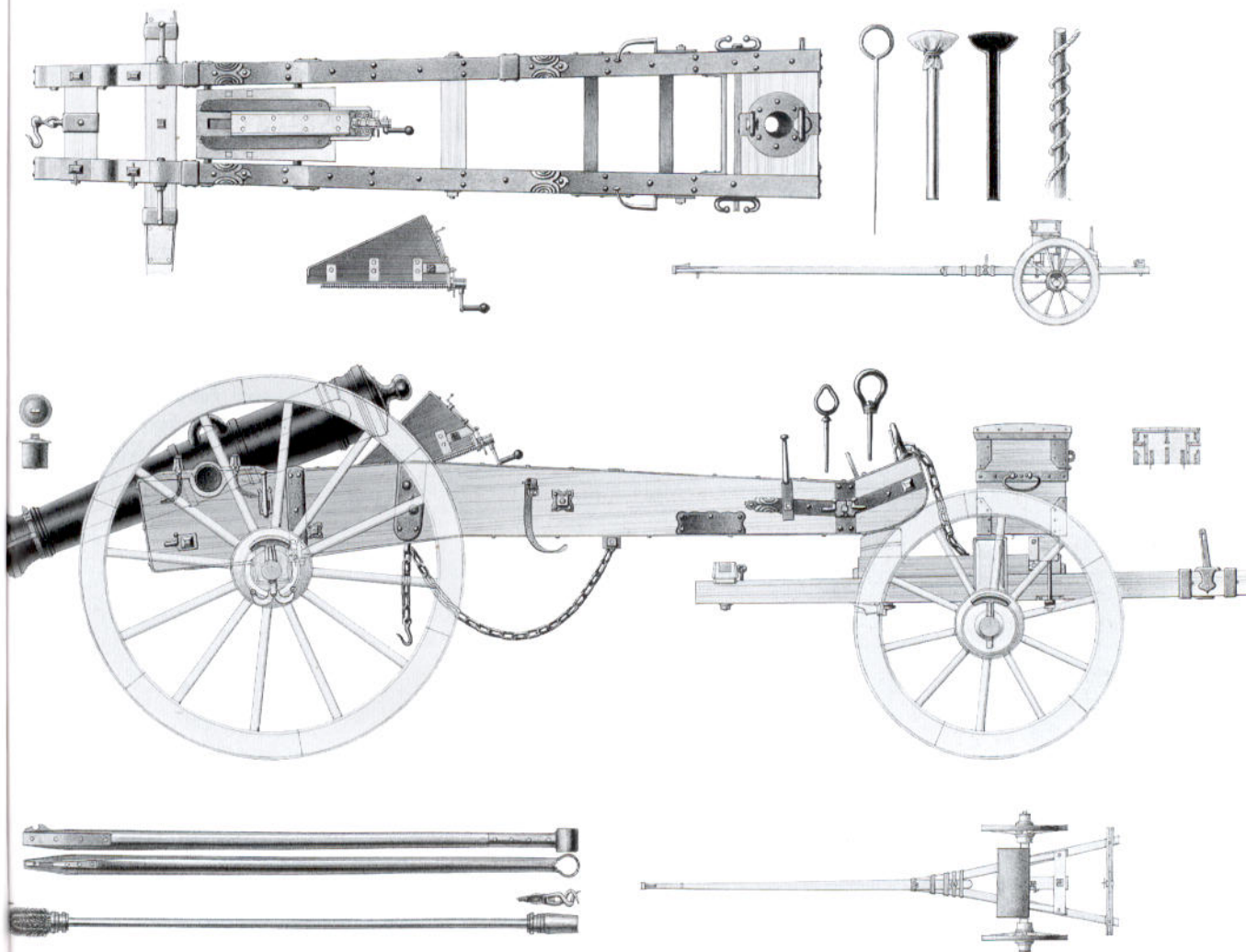

First published in Great Britain in 2003 by Osprey Publishing, Elms Court, Chapel Way, Botley, Oxford OX2 9LP, United Kingdom.
Email: info@ospreypublishing.com

© 2003 Osprey Publishing Ltd.

All rights reserved. Apart from any fair dealing for the purpose of private study, research, criticism or review, as permitted under the Copyright, Designs and Patents Act, 1988, no part of this publication may be reproduced, stored in a retrieval system, or transmitted in any form or by any means, electronic, electrical, chemical, mechanical, optical, photocopying, recording or otherwise, without the prior written permission of the copyright owner. Enquiries should be addressed to the Publishers.

ISBN 1 84176 499 X

Editor: Simone Drinkwater
Design: Ken Vail Graphic Design, Cambridge, UK
Index: Alison Worthington
Originated by The Electronic Page Company, Cwmbran, UK
Printed in China through World Print Ltd.

03 04 05 06 07 10 9 8 7 6 5 4 3 2 1

For a catalogue of all books published by Osprey Military and Aviation please contact:

Osprey Direct UK, P.O. Box 140, Wellingborough,
Northants, NN8 2FA, UK
E-mail: info@ospreydirect.co.uk

Osprey Direct USA, c/o MBI Publishing, P.O. Box 1,
729 Prospect Ave, Osceola, WI 54020, USA
E-mail: info@ospreydirectusa.com

www.ospreypublishing.com

Author's note

I would particularly like to thank Romain and Margot Baulesch for their generous hospitality and Michael Wenzel for his help throughout the research. I would also like to thank Ref. Karl Rossa and the staff of the Kriegsarchiv (KA), Frau Anna Plattner of the Austrian National Library (ONB) and Frau Mag. Ulrike Polnitzky of its Bildarchiv (BA), together with Mag. R. Munzer of the B urgenland Landesarchiv for their help in obtaining drawings and photographs. I should also like to thank Herr Berger, Curator of the beautiful Schloss Forchtenstein (nr. Eisenstadt, Austria), for his prompt assistance with the Cavalry howitzer; John Cook, Alfred Umhey and Roland Kessinger have also provided considerable assistance with illustrations. The Army Museum in Vienna and the British Library also hold useful material. My thanks must also go to Alexandru Bernaz for his help and information.

Artist's note

Readers may care to note that the original paintings from which the colour plates in this book were prepared are available for private sale. All reproduction copyright whatsoever is retained by the Publishers. All enquiries should be addressed to:

Brian Delf, 7 Burcot Park, Burcot, Abingdon, Oxon, OX14 3DH

The Publishers regret that they can enter into no correspondence upon this matter.

AUSTRIAN NAPOLEONIC ARTILLERY 1792-1815

INTRODUCTION

The Austrian artillery of the French Revolutionary and Napoleonic Wars was a creation of the Lichtenstein system of the 1750s. Known for its economy and standardisation of equipment, this system of guns and equipment would remain in use until 1850. The system produced a series of 3-, 6-, 12- and 18-pounder calibre guns, together with 7- and 10-pounder howitzers, based around standardised carriage and wheel designs. In the 1780s more mobile Cavalry artillery guns were added with their *Wurst* seats, on which sat most of the crew. Heavier 12-, 18- and 24-pounders were divided into two types: *Batterie Geschütz* (siege guns) and *Verteidigungs Geschütz* (defence artillery). In 1811 Austria began the establishment of rocket units and in the same year, improved the howitzers by reducing their windage and slightly lightening the 7-pounder barrel. As far as tactics were concerned Austria's gunners, notably Army Artillery Directors, Smola and Perczel, were in the forefront of developing mobile artillery tactics and the increasing use of concentrated batteries, creating a 192-gun battery, the second largest of the period, at Aspern in May 1809.

Weights and Measures

Contemporary Austrian weights and measures were different from modern systems. The guns were originally designated under the Nuremburg weight system, but by the 1790s, the heavier Wiener Pfund weights were in use and are used throughout this book. (See Plate G for ball weights).

Weight

Weights were measured in Löth, Wiener Pfund (Austrian pounds) and Zentner.

32 Löth = 1 Wiener Pfund; 100 Pfund = 1 Zentner

1 Pfund = 560 g = 1.235lb (Imperial pounds) = 1 Löth = 17.5g = 0.62oz;

1.15 Paris livres = 1.2 Nuremberg Pfund

Length

Distances were measured in Zoll (inches), Füsse (feet) and Schritte (paces).

1 Schritt = 2 Füsse; 1 Fuss = 12 Wiener Zoll

Zoll and Füsse were little different from UK Imperial inches and feet.

1 Zoll = 26.34mm = 1.04in.; 1 Fuss = 31.6cm = 1 ft 0.4in.

Angle

The Zoll distance produced the change in angle.

The measurements given in the text are the specifications, although allowance was made for contemporary tolerances in manufacturing.

ORGANISATION AND OPERATIONS

Overall strength

The Austrian army had begun the Seven Years War in 1756 with 203 field pieces and the total number of guns rose steadily to 1,060 by 1780. Before the Turkish War of 1788–91, the number of Cavalry guns (broadly equivalent to the horse artillery of other nations) had been increased to 64 and howitzers to 32. By the end of that war, 72 Cavalry guns were in service and this number had reached 120 by 1800. In 1790, the field establishment stood at 948 field pieces – 798 guns, 86 howitzers and 64 Cavalry pieces. The siege park numbered 252 pieces in 1800 – 128 heavy guns, 32 heavy howitzers and 88 mortars. Of the 1,257 field guns in service in 1805, 184 were Cavalry pieces. Following reforms in 1808, many 3-pounders (pdrs) were left in the depots, so the Austrian field force comprised 742 guns in 108 batteries. The calibres also became heavier: the 1813 Army of Bohemia's 52 batteries included eleven 12-pdr and two 18-pdr batteries with just three 3-pdr batteries for light brigades.



ABOVE Fürst Josef Wenzel Lichtenstein (1704–72), Direktor of the General-Artillerie-Direktion 1751–72 and father of the artillery system which was in service with the Austrian Army for nearly a century from 1753. His guns were modified slightly by Gribeauval into the Napoleonic French guns. See *New Vanguard 66: Napoleon's Guns (1)*. (BA)

Allocation of artillery

Until 1808 the line infantry battalions were supported by their own light guns. These guns were manned by a combination of artillery specialists and *Handlanger* (unskilled labour supplied by the infantry unit). The allocation of guns depended on the terrain and likely opposition. In Italy, most regiments used six 3-pdr weapons (as this usage was experimental, exact deployment is unknown), whereas four 3-pdr and a 6-pdr were more usual in Germany. Some 7-pdr howitzers were added in the early years of the Revolutionary Wars but were quickly phased out.

The remaining guns were located in the Reserve, where they were organised into batteries, which could either act on their own, especially with the advance guard, or in support of the main gun line. Lighter guns were allocated for battlefield support as required and heavier guns already placed in

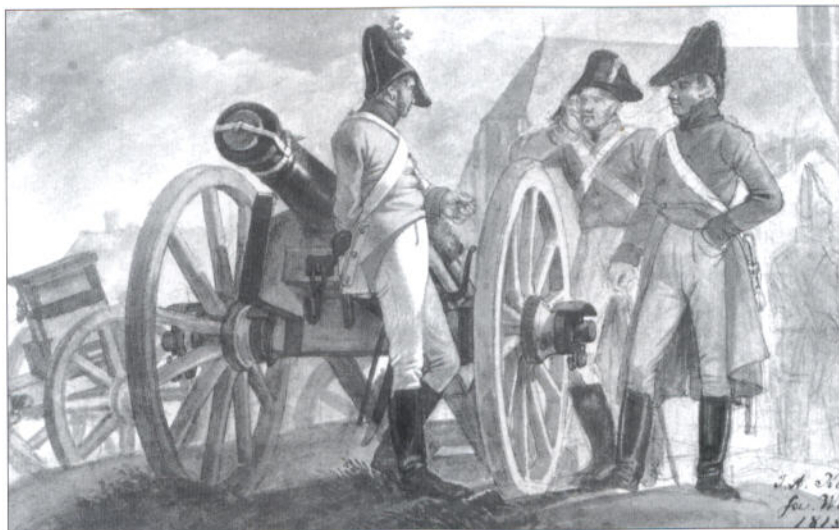

RIGHT A 6-pdr outside the Minoritenkirche in Vienna. The *Mundklotz* (bung) is in the barrel. The front hook and the axle ends are clearly visible. (Klein) (Vienna City Museum)

position at the commencement of a battle. Some 200–400 gunners, depending on the size of army involved, were held with the Reserve to prepare the Reserve guns for movement and replace casualties. In the early 1790s 18-pdrs and 10-pdr howitzers were formed in Position or Reserve batteries. The Reserve had at least a third of all the guns, although this rose to about half in Italy where lighter battalion guns were employed. The proportion of heavy guns in the Reserve depended on the nature of the terrain and likelihood of fortress warfare. As a rule of thumb, one gun per thousand men was kept in reserve for key attacks, especially Cavalry 6-pdrs and some howitzers.

The emphasis in battle was on all three arms working together. Lighter guns would support the infantry; howitzers and heavier pieces would be on the flanks to counter enemy cavalry and pour crossfire into enemy lines. The Reserve guns were assigned by the Artillery Director, who would remain with the Commander-in-Chief throughout a battle. He would give general objectives both for placing guns and their initial fire, but as orders continued to come down the chain of command, the emphasis was on individual officers directing their guns effectively.

The start of a battle was usually marked by concentrated fire against several key points in the enemy line. This fire also helped to screen the initial development of an attack. Although the guns would focus on specific targets, the battery commanders were cautioned to try not to reveal the main axes of an attack with their fire. Artillery fire was thus opened up slowly at 1,800–2,000 Schritte (1,135–1,265m). Musketry was limited to 300 Schritte, so prior to 1808, the battalion guns provided longer range fire and supported the infantry in between volleys. During an advance, battalion guns were usually dragged about 15 Schritte in front of the infantry line, moving up to 100 Schritte ahead as they approached the enemy, which allowed them a wider angle of fire as they engaged their targets. Here they would lay down a sustained fire to soften up the enemy as the infantry moved up. Once the infantry came within the 300 Schritte range of the enemy, the guns were manhandled back to the main line and opened fire from the gaps between the units. Once the infantry closed, the guns were moved to the flanks to enfilade the enemy or fire on their reinforcements. The guns would also support the infantry by firing while muskets were being reloaded. If the infantry were static in a defensive line, they would only open fire if the guns came under enemy musketry. Then the guns would either be withdrawn or the infantry would advance to engage their opponents. (see Warrior 24: Austrian Grenadiers and Infantry 1788–1816 pp. 30–31). Battalion guns were usually deployed in no more than two openings in the regimental line and four guns per gap.

The guns operated on a minimum frontage of 10 Schritte per gun. Lichtenstein had begun the use of *ad hoc* batteries by massing most of the 3-pdrs in groups of four to six with their parent units, where they came under the direction of a senior NCO. In the early 1790s, every third battalion in the *Treffen* (battle line) was assigned two 7-pdr howitzers in

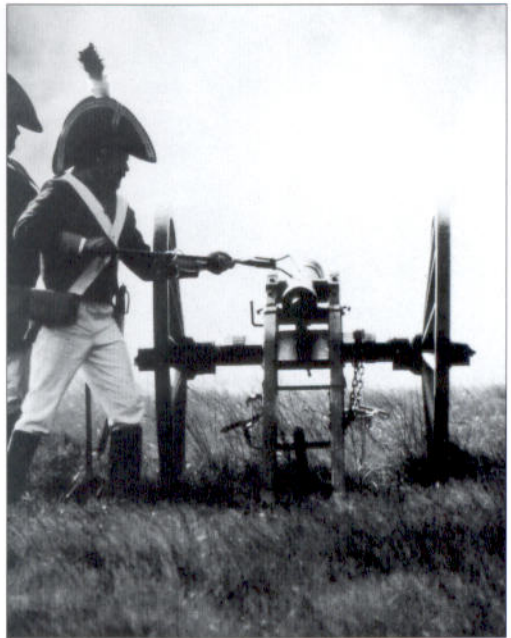

A full size 3-pdr being fired by members of the Artilleriebatterie Wurzburg re-enactment group. (Umhey)

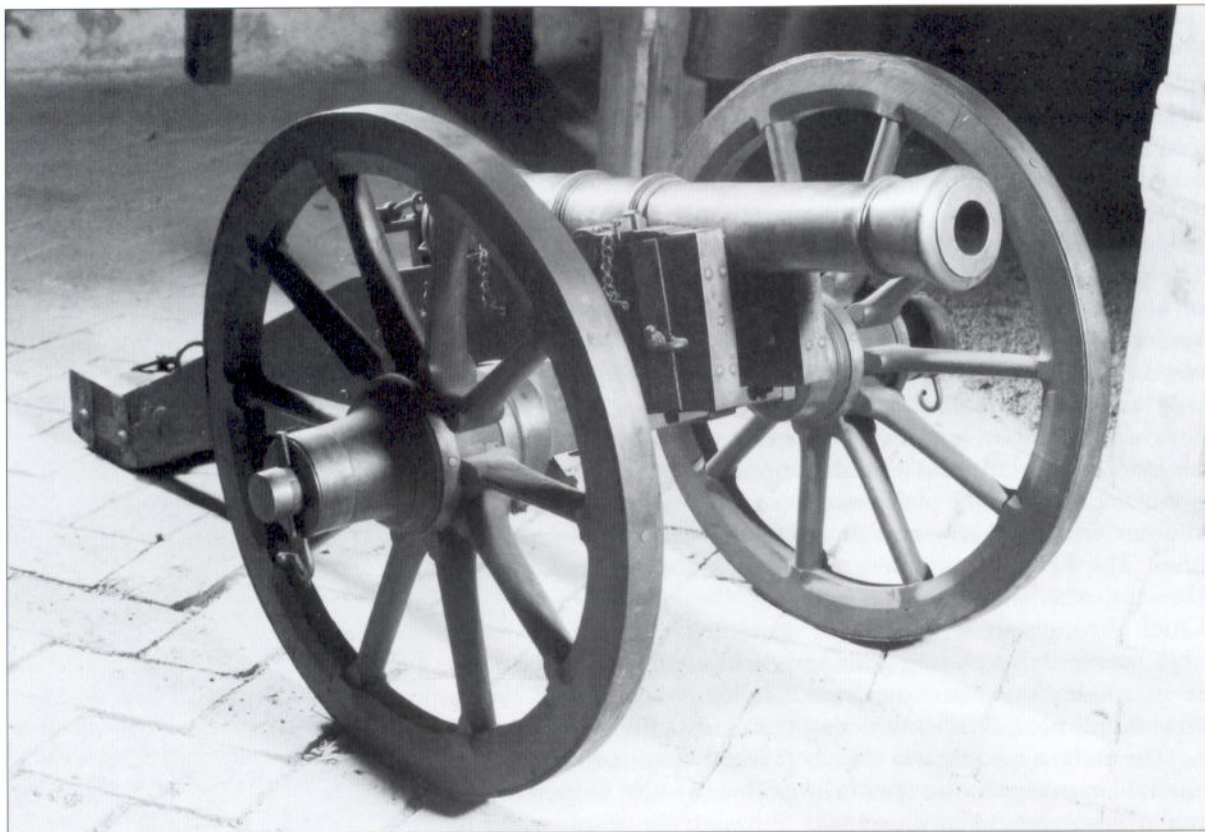

The 1747 system guns continued to be used by the Insurrection militias. This 3-pdr illustrates the heavier features of the older guns, including thicker carriage walls, smaller wheels and a heavier axle. (Forchtenstein Castle depot/Burgenländisches Landesarchiv)

place of its light guns. Infantry detachments would guard guns attached to cavalry. The army reserve guns, which would remain between the second Treffen and the Reserve in two or three groups, were divided into batteries of six guns and two howitzers, together with Cavalry batteries of four guns and two howitzers. The 3- and 6-pdrs usually formed small batteries, but the 12-pdrs would remain in a single central battery or, along with the 7-pdr howitzers, be placed on the flanks to handle hostile cavalry. The heavy artillery reserve was formed into Position batteries, either of six guns or four guns and two howitzers, and were often deployed to add weight to the battle line at key points – a tactic which had proved successful in the War of the Bavarian Succession (1778–80). On the march and in camp, light and Cavalry guns were also attached to both the advance guard and rear guard. Light guns would cross rivers with the first battalions. The 18th century view continued to prevail that each gun represented the equivalent of a flag in the rest of the army, although this might have made the Austrians more cautious in deploying their guns.

A major change came under an Imperial Order of 3 June 1808. Joseph Colloredo, Artillerie-Direktor 1808–09, abolished the battalion guns of the infantry and allocated all pieces to three types of permanent battery – designated as brigade (8 light guns), Position (6 heavier guns and 2 howitzers) and Cavalry batteries (four guns and two howitzers). Only the Grenzer battalions retained their battalion guns. At the same time, a separate Handlanger Korps was created to provide the labourers and the *Fuhrwesen* (Transport) service was militarised. *See also*

Men-at-Arms 223, and 299 pp. 3–12. The brigade batteries would accompany their respective formations and the others would make up the Reserve, many of the 12-pdr guns being emplaced at the start of an action. The new permanent batteries were led by the specialist NCOs (Oberfeuerwerker and Feuerwerker) under the direction of junior officers. Brigade batteries would march, camp and fight with their parent brigades and could be divided into half-batteries if required. By 1813 brigade batteries were mostly comprised of six 6-pdrs and two 7-pdr howitzers. Using 8-gun batteries allowed the guns to fire by half-batteries or in pairs to offer cover while others were being loaded. However, Reserve batteries were specifically forbidden to subdivide. Once they had achieved their objective, they were returned to the army Reserve.

The term 'Cavalry gun' referred to the speed at which these weapons could move and the fact that they would require cavalry detachments to protect them. Cavalry batteries were kept together to act at key points – using their swift movement to launch surprise attacks and batter the enemy front. On the advance they would be positioned on the lead flank. Consequently, on the march they usually accompanied the advance guard or remained in the Reserve. These batteries were assigned to light brigades, comprising light infantry and cavalry. The Cavalry guns would move forward and seize good positions to hold them until the infantry could advance, or cover a retreat, supporting infantry units under threat by firing into following enemy. During a pursuit they would move ahead to sow disorder in enemy ranks. The Cavalry gun teams could be moved forward into the forward line of Masses in the big battles and, if threatened with attack, could limber up and withdraw quickly. Contrary to popular belief, horse batteries did not charge with cavalry. The rationale was straightforward – each artillery horse dragged about four times the weight of a cavalryman and the guns would bog down on soft ground. The guns could also be lost, once the cavalry had engaged and they were vulnerable to counterattack.

Howitzers were not precise weapons, so Smola recommended slow steady fire to drop shells into large formations. Their angle of fire allowed howitzers and rockets to be concealed behind walls for surprise and their own protection. However, the gun commanders had to bear in mind the possible effects of enemy hits on the walls.

With the introduction of permanent batteries, the tactical focus turned to their deployment

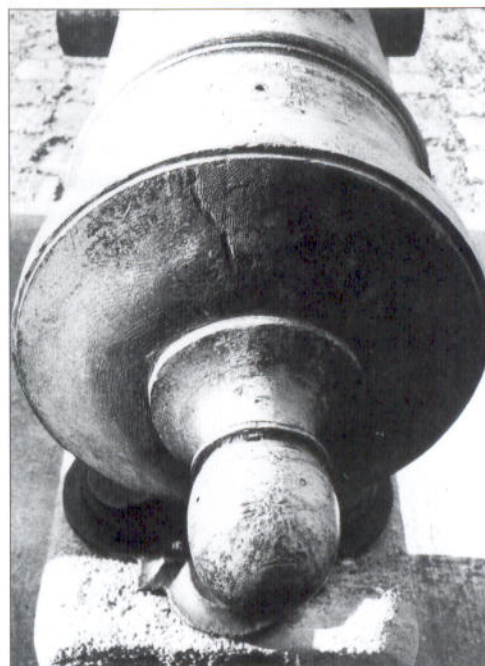

Details of the 1753 and 1780 touchhole designs. The vents were initially drilled at an angle through a rear touchhole support, so that the empty fuse tube was thrown clear of the crew on firing. In 1780 this design was changed to a vertical vent in the main part of the gun, which was easier to bore and, being shorter, was less prone to blockage.



in support of the brigades with the emphasis both on overlapping arcs of fire and the use of Cavalry guns in support of large formations. The 1757 regulations were only augmented in 1809 with the *Exercier Vorschrift mit dem Kaiserlich-königliche ordinaren Feld- und Kavallerie Geschütze sowohl einzeln als in Batterien* (drill regulation for the field and cavalry artillery both individually and in batteries), which modernised the drills, but focused more on battery action. Alongside, *Die Regeln der Placirung des Geschützes im Felde, als Versuch einer systematischen Zusammenstellung derselben* (the rules for positioning guns in the field, as an attempt at their systematic concentration) (1808) appeared as a tactical supplement and the *Beiträge* (contributions to practical field training for the officers of the Austrian army) *zum praktischen Unterricht im Felde für die Offiziere der österreichischen Armee* (practical training manuals issued between 1806 and 1813 for all army officers) included general guidance on tactics and field craft.

Smola summed up his philosophy as:

Advance as close to the enemy line as is possible, given the need for the safety of the guns against an unexpected enemy attack. Artillery is rarely decisive at ranges beyond 800 Schritte; an action at 500 Schritte will usually only last for a few minutes before the outcome is clear. Cavalry guns must make use of their mobility advantage to undertake skilful attacks, especially in actions against enemy cavalry, where a few positions close to the enemy will be decisive, rather than hour-long cannonades, which will tire the crews and use up ammunition pointlessly. When it is possible to advance against the enemy unnoticed, open fire only at the effective range.

Smola then noted that, since French guns had a range advantage, the Austrian gunners should try to close in to 500 Schritte, as experience had shown that the French guns were less accurate at that range. Once the guns got in close, they could decimate the enemy crew and horses with canister. Guns supporting attack columns were to open fire at 800–500 Schritte (505–315m), using canister at the end and focusing on a part of the enemy line. In defensive situations, fire could be opened against a heavy column at 600 Schritte (380m).

The preferred style was to maintain a slow, steady and well-aimed fire. Long-range fire was discouraged as it used up ammunition and caused the barrel to heat up. The best angle was across the enemy line or, if possible, enfilading it or striking at narrow chokepoints where enemy forces were concentrated. This had proved more effective against infantry than close-range canister. The guns were not to move beyond infantry support, so that these troops could arrive before enemy cavalry, and never more than 200 Schritte away, unless supported by light cavalry or infantry detachments.

The first task for the battery commander was to check the local area for ditches and streams, which might hinder movement. Officers were recommended to make good use of raised roads and dips in the ground for cover – a slope of 2 per cent was best for firing positions. If there was time, *Zimmerleute* (infantry pioneers) and *Handlanger* were sent out to remove obstacles. In broken ground, fire was to be directed on the roads and main exit points from congested areas. Where the enemy were amongst trees, firing into the upper branches was recommended to

cause confusion. In attacks on fortified positions, the guns were kept in a single line and coordinated their fire until the enemy was weakened significantly, then they would move up to attack at close range with canister. On the defensive, the guns were to be emplaced to maintain cross-fire by covering the arcs of fire of the adjacent guns. Officers were to look for positions protected by broken or swampy ground to the front. Under enemy fire, guns were to alter position half a battery at a time. When enemy fire was superior and finding its range, the guns were to be moved sideways. If enemy cavalry appeared, the guns could be abandoned and the gunners take cover amongst the infantry Masses – unless enemy cavalry had draught teams with them, the pieces were quite safe from removal. Were the gun in danger of being captured, the crew would render it ineffective by driving a soft, square nail into the touchhole and bending the protruding part with a square-headed mallet. Inside the barrel, the rammer was used to bend the lower end. One means of removing a nail was to run *Lunte* (slow-burning rope used to ignite the fuse – see plate D) down the barrel and load a charge. The *Lunte* was then lit and the nail blown out.

Reflecting the changing nature of warfare, guns became heavier and steadily moved from the role of infantry support weapons to providing the main force of an attack or defence in pre-organised batteries attached to brigades and divisions. Increasingly heavier concentrations of guns in improvised batteries had begun at Neerwinden in 1793 with Smola's battery to counteract the heavy French columns. At Wurzburg in 1796, 17 guns in a single line swept the centre of the field and at Marengo in 1800 three cavalry batteries (18 guns) were deployed in a line. Some 192 guns tore into the French at Aspern-Essling in May 1809, where Smola also positioned enfilading batteries on the flanks and poured 100 rounds a minute into the French defenders. In October 1813, at Lieberwolkwitz, Oberst Stein aggressively moved up with two heavy 12-pdr batteries to deny a rear rallying area to the French cavalry. Defensively, the expert handling of Austrian guns saved several precarious situations – Smola's guns offset the French numerical advantage at Messkirch (May 1800), then at Austerlitz (December 1805), Major Frierenberger's battery enabled Bagration's Russian troops to extricate themselves from the Allied left and two batteries halted Beaumont's cavalry pursuit at the end. From the main 1809 battles at Aspern and Wagram onwards, the heavier guns in pre-constructed positions and artillery generally came to dominate the battlefield. Nevertheless, considerable quantities of ordnance had to be fired to inflict casualties. At Aspern approximately 55,000 artillery rounds were fired and the entire French casualty total from all causes was about 22,000 men.

Personnel

The artillery was a single force within the army under the Director General of Artillery. From 1772 the artillery was organised into the *Feldartillerie* (field artillery), the *Garnisonsamt* (garrison force) and the *Feldzeugamt* (administration organisation with responsibilities across the artillery service).

The field artillery was mustered in three regiments (increased to four in 1802), each comprising four battalions which subdivided into four companies, expanded to a total of 22 in wartime (18 for the Wars of

Artillery crew 1800. Note the man with the Besteck (vent pricker). Each man carried a small black leather box on his belt worn to the front, in which he carried his tools, together with a Besteck on a yellow-black cord. Many wore canvas breeches for field service. (Seele)



Liberation). In 1805 an artillery company was composed of 4 officers, 14 NCOs, 159 gunners and 5 others. This was expanded in 1808 to 5 officers, 14 NCOs, 2 musicians and 180 men (increased to 200 in wartime).

The garrison artillery was formed from men unfit for field service and organised in 14 districts, manning the fortresses and other key places, the siege guns and, where necessary, with the additional task of reinforcing the field crews.

The Cavalry guns came under the authority of the *Feldzeugamt/Zeugwesen*, which also directed manufacture and repair of guns and equipment, together with powder supply and testing. A detachment would accompany each army reserve artillery park on campaign. The main arsenals were at Vienna, Prague, Olmütz and Budweis with many smaller reserves distributed across the Habsburg Lands.

Alongside the new guns introduced by the Lichtenstein reforms, the 300-page *Reglement für das Kaiserlich-Königliche gesammte Feld-Artilleriecorps* was issued in 1757. This covered organisation, administration and technical knowledge as well as pure *Exercier* (drill). The third chapter of Part 2 covered artillery skills, maths, testing, construction of fortifications and magazines as well as powder stores. In contrast to the custom in other arms, the emphasis was very much on the personal initiative of officers and treatment of soldiers as individuals. The introduction to the manual pointed out that the *Reglement* could only provide general rules as most situations would require individual judgement dependent on circumstances. At sieges, artillery commanders were permitted to send out individual officers to reconnoitre the terrain and roads to test their capabilities.

By 1790, Austria's artillery was considered the best in Europe, primarily because of its technical specialists, the Bombardiers. No other army possessed similar artillery personnel. Prince Lichtenstein had established a specialist Artillery Korps school near Budweis (Bohemia) in 1744, which also included depots and laboratories. Officers together with able NCOs and gunners were instructed in both the theoretical and practical aspects



of artillery subjects. After a move to the Artillerielyceum in Vienna in 1778, the Bombardier regiment was established as the elite of the artillery in 1786, when its home was renamed the Bombardier Korps school. The Korps was composed of four companies, expanded to five in 1802. The Bombardier companies were commanded by the lecturers and comprised 1 Hauptmann, 3 Leutnants, 24 Oberfeuerwerker, 36 Feuerwerker, 6 Kadetts and 108 Bombardiers.

This unit was the main training school for the NCOs and officers, drawing on the most intelligent and able recruits, who were trained for up to seven years in a mix of advanced academic and military subjects. Winter work focused on theory, summer on practical exercises. They would join military exercises and perform garrison duties. The first five years focused on arithmetic, geometry, two years of advanced maths, mechanics and ballistics. Throughout, they undertook the same general artillery training as gunners, with additional classes in geometric drawing, topography and surveying, fortress warfare, tactics, logistics, staff and adjutant work. After five years, most were appointed as Feuerwerker or Korporals and joined the regiments, particularly the howitzer crews. The best candidates were promoted to Oberfeuerwerker and stayed for a further two years, focusing on physics and finally, chemistry and technology, after which they would join the regiments. Most would be commissioned within an additional four years.

Gunners were paid one-third more than the equivalent ranks in the infantry and this, together with the humane conditions prescribed by the 1757 regulations, enabled the artillery to recruit freely amongst the more intelligent men in the rest of the army and to seek civilian volunteers, especially skilled tradesmen, across the Empire. Volunteers, who had to be Imperial subjects, were chosen for their self-reliance and decisiveness, alongside the ability to absorb the technical details of the arm. The training and knowledge required meant that service was for life, reduced to 14 years under the 1802 reforms. Part IV of the regulations required the men to be strong and solidly built, over 5 Füsse 4 Zoll (1.68m) and fully literate in German; they had to be unmarried and more mature men, especially from rural areas, were preferred. Many gunners came from Bohemia (western Czech Republic), where much of the artillery was based.

Bombardier school at the Rennweger Kaserne (barracks), home of these elite gunners 1802–49. This was the best route for intelligent army recruits to progress quickly to senior NCO or officer rank. (KA)

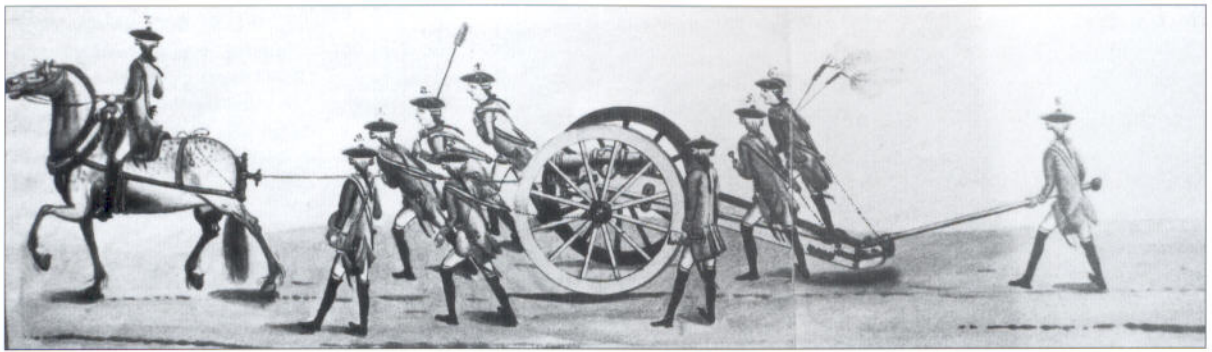

A 7-pdr howitzer being moved. This howitzer was allocated a three-horse team, so to move it in action the lead horse was unhooked from the limber and then connected by the drag rope to the front hook on the carriage. Manpower was also provided by the crew who would drag the gun by means of canvas straps slung over the shoulder nearest the gun and connected to it by ropes, which hooked through the drag hooks at the front and rear of the carriage.

Under the 1786 regulations the ordinary recruit, often as young as 15 or 16 years old, spent one year as a gunner in the Elementary School. The recruit was to be subjected to the minimum corporal punishment and educated. He would first be taught basic musketry and infantry drill in small formations, before moving on to artillery training. The gunners would practise twice a week with special 1-pdr training guns. Then, in the peacetime *Campement* (training camps), gunners would train in all the wartime drills in small *Korporalschafter* (groups under a *Korporal*) and then move up in steps to the summer field camps, which conducted exercises on a regimental scale. As trained crewmen, they would then join the Regimental School to take a practical and theoretical one-year course, including maths, range calculation, elevations and charges, battery construction and manning/working the different types of ordnance. To improve teamwork and efficiency, individual gunners were attached to a specific gun throughout a campaign, developing a pride in its care. The guns would then be allocated to the armies as required, when the campaign began.

In 1757 Lichtenstein established an Artillery Fusilier Battalion both to guard and assist with handling the guns. Disbanded in 1778 and re-established in 1790, it comprised 8 companies, and provided *Handlanger* for the Reserve guns until 1802, while the parent infantry units supplied the unskilled labour for the battalion guns. The failure of ad hoc arrangements in 1805 for the Reserve guns led to a new *Handlanger Korps* being formed in 1808 to provide labour to all the guns as required, which was expanded quickly to 40 companies during the 1809 war and 38 in 1813, each company servicing two or three batteries.

Aside from the Cavalry pieces, which did not use them, the number of *Handlanger* depended on the weapon's size:

CREWMEN PER GUN (INCREASED CREWS OF 1813-14, 1813 NUMBERS IN BRACKETS)

	Korporals	Gunners	Handlanger	Horses per team
3-pdr	1 per pair	4 (5)	4 (6)	2
6-pdr	1 per pair	4 (5)	6 (8)	4
Cavalry 6-pdr	1 per pair	6	0	6
7-pdr howitzer	1 per pair	4 (6)	7	3
Cavalry 7-pdr howitzer	1 per pair	7	0	4
12-pdr	1	4 (5)	8 (10)	6

In battle

The artillerymen concentrated on directing, loading and firing the guns, the remaining simpler functions being performed by the Handlanger. The No. 1 gunner inserted the charge and shot into the muzzle, No. 2 (a Handlanger) rammed it home and cleared the barrel with the sponge after firing. The chief gunner was No. 3, the *Vormeister* (gun commander) who was often a Bombardier, as were many *Korporals*. He cleared the touchhole and, while the charge was being loaded, kept his thumb (protected by a leather guard) on the vent to prevent burning embers from escaping through it. He then spiked the charge bag with the *Besteck* (or *Raumnadel* – vent clearer/powder bag pricker) to keep it in position, while the rammer was removed and pushed the *Schilfrohrbranrohr* (*Brandrohr* – ignition fuse) into the touchhole; he would also direct No. 5; the Handlanger holding the traversing spar and the Handlanger moving the gun. When ready, the *Vormeister* would order No. 4 (a gunner) to fire the *Brandrohr*. No. 4 carried two *Zundröte* (fuse lighters) and always had one alight unless there was no enemy threat. If quick fire was required, the *Lichteln* (tapers) were used and the *Brandrohr* inserted without the paper being removed. No. 6 moved ammunition up from the box about 12 *Schritte* behind the gun, taking six cartridges at a time in a canvas bag, whenever the immediate supply was down to two. No. 7 would get rounds from the reserve carts.

Due to the technical knowledge required for howitzer operation, two Bombardiers were always allocated to these pieces. For the ordinary weapons, they were the *Vormeister* (No. 3) and No. 8, responsible for preparing the shells; Nos. 1 and 4 were gunners and the rest were Handlanger. On a Cavalry howitzer, No. 1 was a Bombardier dealing with the shells, the rest of the crew being 5 gunners.

Oberst Smola directing his Cavalry artillery battery at Neerwinden in 1793. Part of the advance guard, his battery plus two 3-pdrs blocked Miranda's French division for several hours. Forced eventually to pull back, Smola added ten 12-pdrs, two 3-pdrs and two howitzers to his force and put the French to flight. His Cavalry guns then joined a counter-attack. The *Vormeister* has his thumb, protected by a leather guard, over the vent to prevent the emission of gas and burning powder through the vent while the round was being loaded. (BA)



Tactical diagram: cavalry guns covering a withdrawal, from Plate 46 of the 1807 *Kavallerie Reglement*. Austrian cavalry are withdrawing *en echelon* as cavalry guns fire on the advancing enemy from in front. Part of the battery would move to the enemy flank to pour enfilading fire across their line.

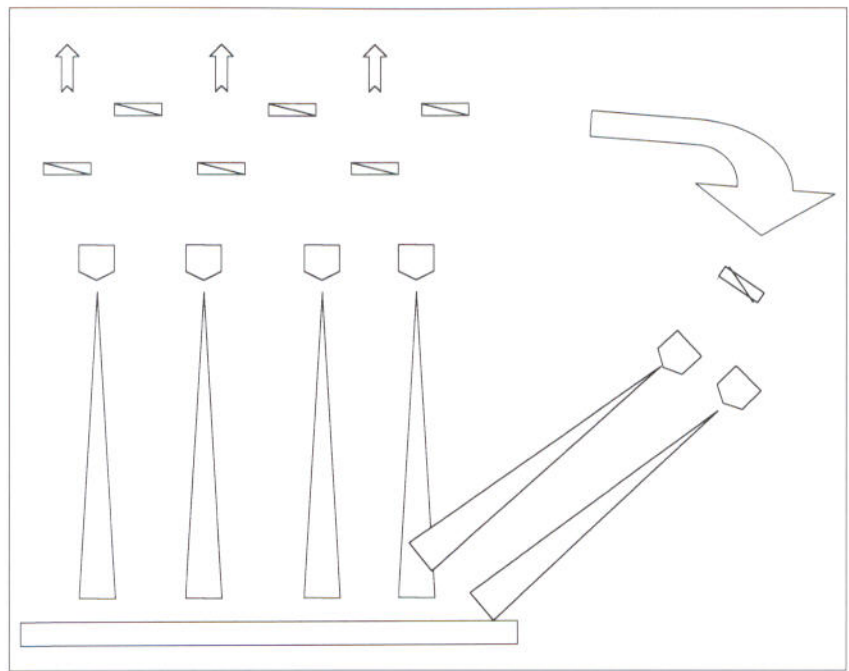

When a gun's aim needed to be changed, a Handlanger would manoeuvre it with the traversing spar by swinging the trail. In the case of lighter guns, to move the whole gun over short distances up to about 500 m, four Handlanger would heave on two bars, each inserted through two rings at the front of the carriage (this fitting was abolished in 1808). The remaining Handlanger, and some gunners (depending on the number of Handlanger on each gun) pulled on the carriage's hooks by ropes attached to slings worn across their chests. Fresh Handlanger could haul guns more quickly than horse teams.

In action, the barrel would be wiped after each shot during slow fire and after every third shot when firing rapidly. The guns could be fired at 7–8 rounds a minute, although this was reduced to 5–6 per minute when the gun was aimed and they could fire 4 aimed rounds a minute without difficulty. This rate was, however, often slowed by smoke, which would obscure the target, as happened at Lodi in 1796. The recoil on firing was 7–8 Füsse for the field guns, although it was significantly less for 3-pdrs.

NUMBER OF GUNS, CREW AND WAGONS PER BATTERY (1808)

Battery	Guns		Wagons		Crew	
	Cannon	Howitzers	Ammunition	Baggage	Gunners	Handlanger
3-pdr brigade	8	–	8	2	32	32
6-pdr brigade	8	–	8	2	32	48
6-pdr position	4	2	6	1	20	38
12-pdr position	4	2	6	1	20	46
6-pdr Cavalry	4	2	3	–	32	0

Note: The number of ammunition wagons includes the equipment wagon for the howitzer; in addition to those shown six forage wagons accompanied a 6-pdr Cavalry battery.

EQUIPMENT

The Lichtenstein system

After the Austrian Succession War (1740–48), the artillery clearly needed a radical overhaul. Under its Director since 1744, Prince Joseph Lichtenstein, a whole new system was introduced from 1753, providing Austria with the key advantage of having the best guns in Europe during the Seven Years War (1756–63). The Frenchman artillerist Jean Baptiste de Gribeauval essentially copied the designs in the 1770s and developed them into heavier weapons with longer 18-calibre barrels. As a result, although muzzle velocities were similar and Austrian guns of the same poundage were only slightly lighter than their French counterparts, Austrian guns were largely outranged and outpunched by the bigger calibre French guns throughout the Revolutionary and Napoleonic Wars. The difficulties of obtaining northern European heavy draught horses after 1795 also limited the use of heavier calibres by the Austrians in the field.

The bronze cast field guns (a mixture of 10 parts tin with 100 parts copper) were of 3-pdr, 6-pdr and 12-pdr calibre, all with barrels of 16 calibres in length. The 18-pdr Lichtenstein gun, which required a team of eight horses, remained in the inventory, but after the early years of the Revolutionary Wars was rarely used in the field until the Wars of Liberation. The barrels and metalwork were painted black, while the carriages were painted Imperial yellow (a light ochre colour). These new barrels became less heated during rapid fire.

A major innovation of the Lichtenstein system was the reduction in windage (the difference between the barrel bore and the round diameter), which made the guns more accurate and increased the range by preventing the force of the charge being dissipated. The 3-pdr's was just 0.125 Zoll (3.3mm), the 6-pdr's was 0.174 Zoll (4.6mm) and a 12-pdr was 0.204 Zoll (5.38mm). Improved boring techniques reduced the howitzer windages of 0.2085 Zoll (5.5mm) for a 7-pdr and 0.25 Zoll (6.5mm) for a 10-pdr by about 0.08 Zoll (0.21mm) from 1811.

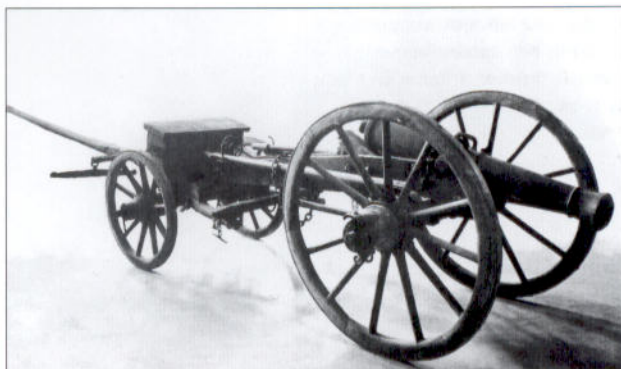

ABOVE A 6-pdr gun from the right. Note the substantial brake chain and the barrel of the 1780s' design with simpler handles. The traversing spar is on the hooks. This illustrates the two main wheel sizes of the Lichtenstein system. (BA)

GUN DIMENSIONS

	External Barrel length (Zoll/cm)	Weight (Pfund/kg)	Traube (Barrel rear counterweight) (Pfund/kg)
3-pdr	35.8 (94.3)	421 (236)	29 (16.25)
6-pdr	60.1 (158.3)	692 (388)	43 (24)
6-pdr Cavalry	54.95 (144.8)	690 (386)	none
12-pdr	75.8 (199.7)	1,376 (771)	86 (48.2)
18-pdr	86.78 (228.6)	1,980 (1,109)	126 (70.6)
7-pdr howitzer	35 (92.2)	500 (280)	100 (56)
7-pdr (1811)	34.5 (90.9)	490 (272)	100 (56)

RIGHT A 6-pdr gun from the left with its sponge/rammers and trail spike. The muzzle protruded 8 Zoll from the front of the wheel. The left side supports are carrying two sponge-rammers with six lines of bristles on the sponge. (BA)

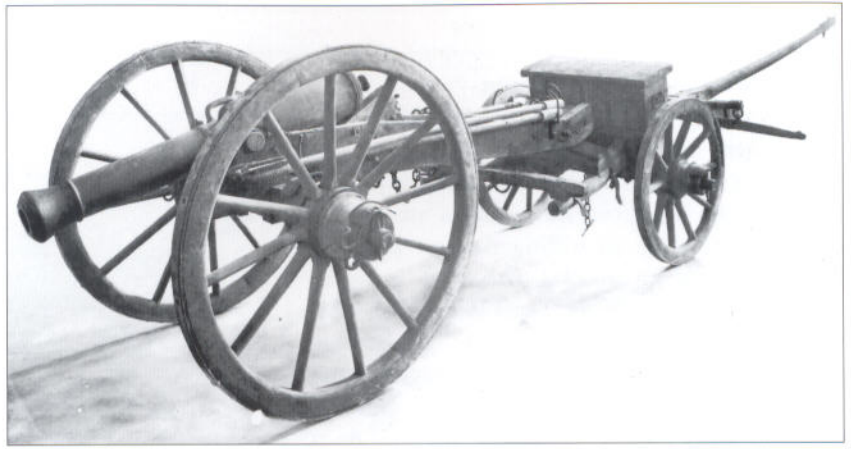

The ordinary weapons were elevated with a screw-driven wedge, while the Cavalry barrels were operated by a V-shaped platform. These elevations were limited as any elevation more than 13 degrees would damage the carriage on firing; a depression angle of 4 degrees was the maximum recommended. The maximum angles were:

	Elevation (degrees)	Depression
3-pdr	27	6.5
6-pdr	23	11.5
6-pdr Cavalry	14	6.5
12-pdr	21.5	8.5
7-pdr howitzer	30.5	4.5
7-pdr Cavalry howitzer	22.5	5.5

RIGHT The 12-pdr gun barrel had two positions – one for firing and a second set of rings, which are just visible by the wheel rim. This spread the load evenly across the carriage and limber wheels for movement of the gun. (KA)

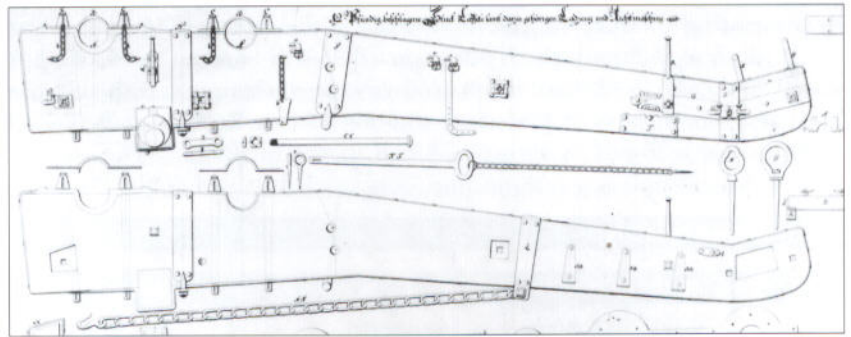

BELOW A 7-pdr howitzer and ammunition box. The howitzer carriage was stronger, with a higher shoulder to support the bigger barrel. (KA)

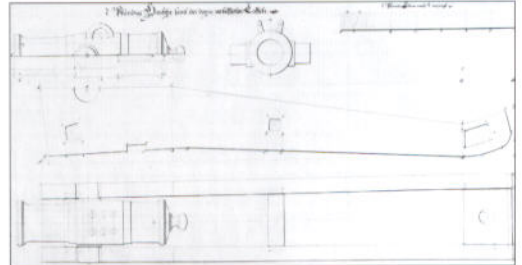
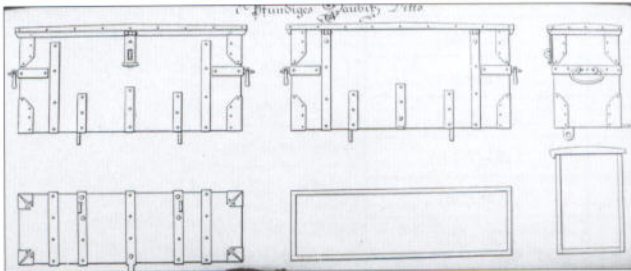

Gun carriages and limbers

Constructed with the best quality oak or elm wood, the 1753 carriages retained the overall shape of the earlier designs, but were significantly lighter. The loss of wood strength suffered in the reduction in the thickness of the walls was compensated for by the addition of three metal cross-ties towards the lower part of the trail and a complete metal strap around the edge of each wall. The inserts for the barrel trunnions were moved forward on the carriage, moving the centre of gravity forward, and thus making the trail easier to handle.

The system was based around a universal axle, which was 5 Füsse 6 Zoll long (173.8cm) and made of elm wood. It was 4.25 Zoll wide, tapering to 2.9 Zoll to accommodate the wheel. There were just two types of wheel (six and five pieces) for all carriages and wagons, which made the provision of spares significantly easier. A pair of spokes connected each rim piece to the central hub with a drilled size for all wheels to allow 0.83 Zoll (2.2mm) play.

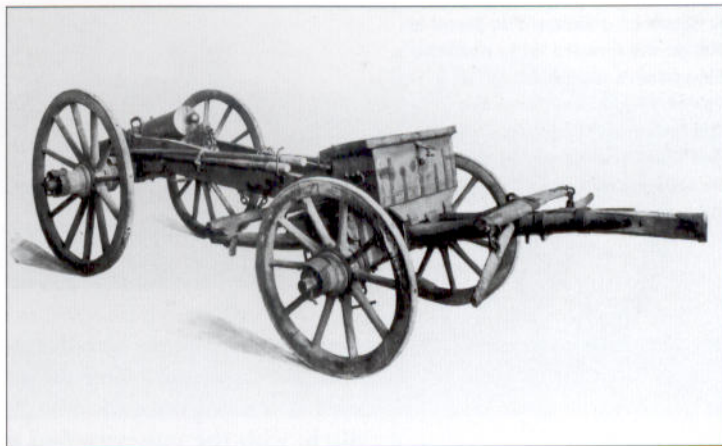

A 6-pdr gun from the rear. Note how flat the limber pieces for the rear pair of horses are. The wheel rims have also been modified by nails driven through the rim into the spoke. The sponge-rammers are secured with a leather strap in the centre. (BA)

CARRIAGE DIMENSIONS (ZOLL (CM))

	Length	Height (front)	Height (rear)	Wall thickness
3-pdr	92.66 (244)	10.92 (28.76)	6 (15.8)	2.5 (6.59)
6-pdr	104.75 (275.9)	12.25 (32.27)	7 (18.44)	3 (7.90)
12-pdr	121.15 (319.1)	15.41 (40.59)	8.67 (22.84)	3.75 (9.88)
7-pdr howitzer	104.5 (273.9)	15.08 (39.72)	7 (18.44)	3.25 (8.56)

At the trail end were two standing rings. The smaller forward ring was fixed, but the rear ring could be turned, both to aid lifting the trail from the limber and so that the gun could be directed with the traversing spar, while the trail was fixed to the *Schleppseil* (rope). At both ends were the drag hooks for the lines. At the front on the *Stirn* (front carriage wall) was a single hook for securing the rope, when the gun was being pulled by horses from the front. When this was being done a pair of horses (or the single horse from a 7-pdr howitzer) was unhooked from the limber and attached to this hook by means of a *Deichselstangen-Tragstrick* (drag rope), which connected up to the hook with an eye and the horses' limber bar by a simple T-piece. To maintain traction when connected to the hook, the bar was raised to about 2 Füsse (63cm) above the ground by shortening the chains by tying them through the rear harness. In action, the limber was located 10 Schritte behind the gun position.

The 22 Füsse-long *Schleppseil* rope was often used on the battlefield as a quicker alternative to limbering the gun properly. Any movement of 100 Schritte or less was normally conducted with the *Schleppseil*. It was usually fixed to the short chain, secured on the strongpoint just behind the limber axle, but when the gun went into firing operations, the other

A 12-pdr on a limber. The barrel is still on the forward firing position. Feuerstein's radical design of a lighter 12-pdr made field use of this heavy calibre possible for the first time. The traversing spar can be seen hooked on to the rear support. (BA)

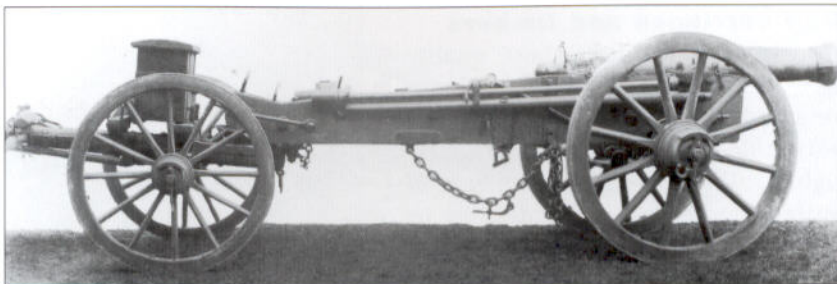

end with its T-piece was slung through the immovable ring on the trail end. When withdrawing the gun, it was thus still possible to fire the gun as it was being moved. The Schleppeil was also used when crossing a ditch: with the gun attached to the limber by this long rope, the horse team would cross the ditch slowly. Once they were on the far side and the limber wheels were just reaching the far bank with the whole system in a straight alignment, the order 'Marsch, marsch' would send the horses racing forward and as the Schleppeil went taut, the gun would be dragged through the obstruction.

TURNING CIRCLES (LIMBERED) (FÜSSE(M))

3-pdr gun	21.5 (6.8)	7/10-pdr howitzer	22.3 (7.1)
6-pdr gun	22.75 (7.2)	7-pdr Cavalry howitzer	33 (10.4)
12-pdr gun	26.75 (8.5)	6-pdr Cavalry gun	36 (11.4)



These 3-pdr barrel handles are of the later, simpler design. The trunnion diameter was 2.72 Zoll. (Wenzel)

Rear view of a 3-pdr illustrating the metal ties securing the trail and the aiming wedge. See also MAA 096: *Artillery Equipments of the Napoleonic Wars* p.5, for another rear view. A 3-pdr mountain gun, introduced in 1772, used the same barrels, but lighter carriages. (Dolleczek)

Cavalry artillery guns

After some early experiments during the Seven Years War, a system of mobile artillery was established in 1776 by an Imperial Commission. The cavalry were to receive batteries of four 6-pdr guns and four 7-pdr howitzers. Feldmarschall-Leutnant Freiherr von Rouvroy, who had directed the first designs, wrote the new regulations, which were

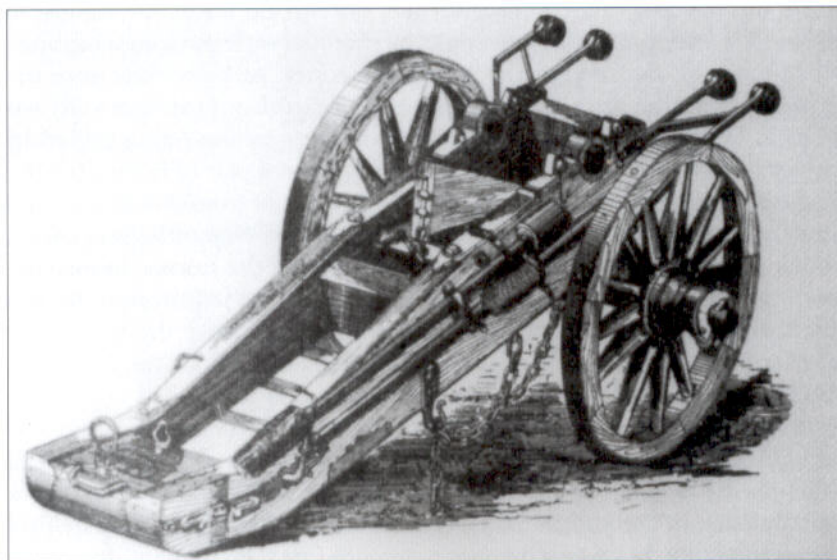

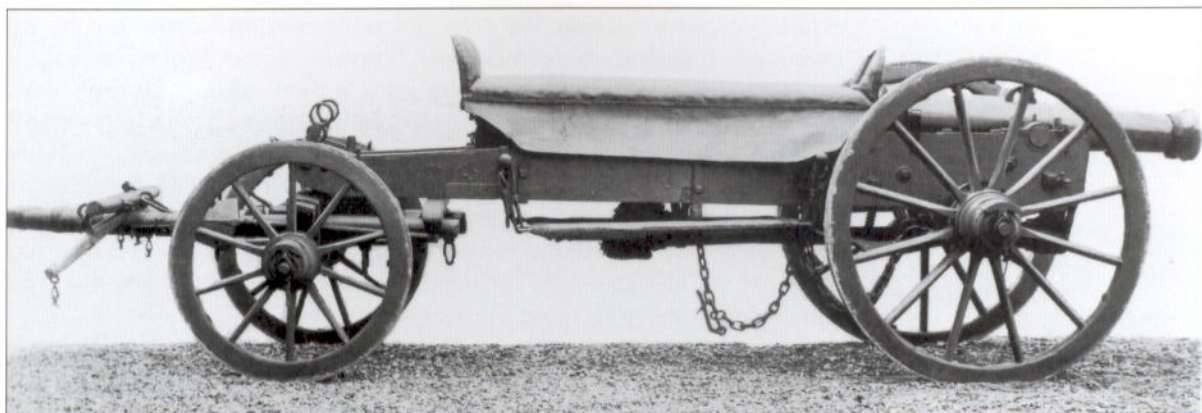

issued on 20 April 1778. Each pair of 6-pdr guns was directed by a Kanonier-Korporal; a Bombardier commanded each pair of 7-pdr howitzers, both riding their own horse. New guns were ordered over the winter of 1778–79 after early success in the War of the Bavarian Succession. Each group of four guns was supplied by a two-wheel ammunition wagon and every four howitzers had a two-wheel *Feuerwerkskasten* (howitzer ammunition and equipment) wagon. All the Cavalry artillery pieces now had six-horse teams and each howitzer was now directed by a Bombardier. After the war, a particular emphasis was placed on training with these mobile guns. Each of the three artillery regiments was equipped with a pair of 6-pdrs and a 7-pdr howitzer for training purposes. One company per regiment would serve these weapons, although all artillery were trained to use them. By the start of the Turkish War in 1788, each battery comprised two guns and one howitzer.

In 1790, on mobilisation, the Cavalry guns were allocated in batteries of four guns and two howitzers, taken into the artillery and teamed with horses from the Kavallerie Geschütz-Bespannungs-Divisionen, which had been formed in 1783 to cream off the best drivers and horses. Each division serving a battery was commanded by an artillery officer, whose deputy, the Oberfeuerwerker, was responsible for the howitzers. The horse team was directed by a Fuhrwesen Korps officer, who was subordinate to the artillery commander.

The guns were essentially the same as the line versions, except that the 6-pdr barrel did not have a *Traube* (backweight). Unlike the horse

ABOVE A 6-pdr Cavalry gun. Although the forward bar on the limber was a common feature of all the field guns, it was especially important for carrying the extra weight of the Cavalry guns. Two sponge-rammers are in the underneath position. The seat cover has a large side flap as weather protection for the ammunition. (BA)

BELOW An 1807 6-pdr Cavalry gun barrel without the *Traube*. (Wenzel)

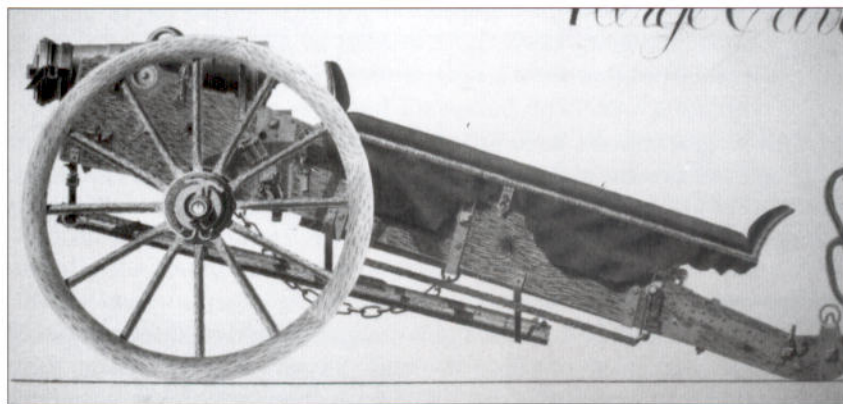

An early design for the Cavalry artillery howitzer. The metal fittings were reduced by the time it entered service (see Plate C) and the forward drag ring had been moved back from under the seat to the end of the trail. On this side, the leather seat cover has been cut to reveal the lock on the Wurst ammunition box. (Burg Forchtenstein, Austria)

artillery of most nations, the crew did not travel on horses, but on an extended trail with a leather seat, known as the Wurst (sausage). Although this made the whole gun system about 20 per cent slower-moving than its counterparts in other armies, it made for faster mounting and dismounting, one or two rounds being fired in the time which other nations' gunners required to dismount. Additionally, fewer crewmen had to be taught to ride.

The axle was very similar to the standard, although the wheel spar was set back on the axle block, because of the weight of the Wurst seat. The 1809 regulations prescribed the seat's contents:

	6-pdr	7-pdr howitzer
Schleppseil with an iron T-piece	1	1
Ball rounds	4	–
6 Löth canister	10	–
Schrotbüchsen	–	5
Shells	–	2
16 Löth howitzer cartridge	–	12
24 Löth howitzer cartridge	–	20
32 Löth howitzer cartridge	–	20
40 Löth howitzer cartridge	–	20
Brandrohr	100	80
Taper lighters	20	20
4 Pfund roll of Luntten	1	1
Cartridge carrying bag	2	1
Brandrohr carrying bag	1	1
Canvas pouch with 4 Pfund of powder	–	1
Arm sleeve	–	1
Worming tool (in lid)	1	1
Vent pricker (in lid)	1	1
Touchhole nail	1	1
Square-head mallet	1	1
Padlock	1	1
U-bolt	1	1
Shovel	1	1

The six packhorses accompanying each Cavalry piece carried two large natural brown leather bags down each side, one above the other. Each horse carried 20 rounds for a Cavalry gun and 10 shells for a Cavalry howitzer.

Siege and defence guns

In 1753 Feuerstein, Lichtenstein's gun designer, had developed a series of heavy Batterie guns of 12-, 18- and 24-pdr calibre which were approximately 50 per cent larger than their Lichtenstein field equivalents.

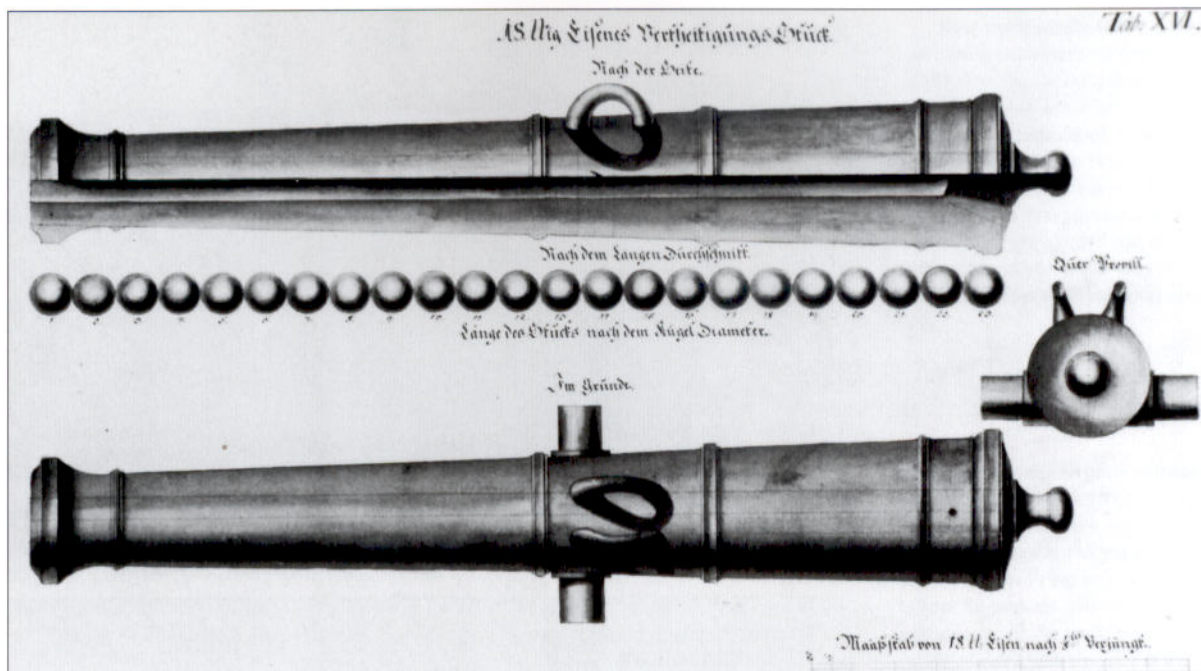

These guns were paired off as long and short versions with barrels of 20 and 22 calibres, and in 1764, a medium size barrel was added for the 12- and 18-pdrs. The greater weight of the barrels meant that these guns had slightly larger 54 Zoll wheels and thicker axles than the field guns (see Plate E). In 1776 improvements in manufacture allowed the introduction of longer iron guns, which were designated *Vertheidigungs* (defence) guns for fortresses and other strongpoints, which were modelled on the former long-barrel Batterie guns. The weight of the 12- and 18-pdr barrels meant that these required the 54 Zoll wheels, but the lighter 6-pdr (26 calibres long and weighing 1,278.6 Pfund/716kg) used the 51 Zoll type. All the defence gun wheel rims were thinner as they were rarely moved in the fortresses, where they could also be supplemented by mortars. The *Vertheidigungs* carriages were modelled on the 18-pdr field carriage and had no metal reinforcement around the hole at the end of the trail, which accommodated the limber spike.

The bronze guns were redesignated as *Belagerungs* (siege) guns and were overhauled in 1780 into a set of heavy and light barrels, the light 12- and 18-pdr barrels replacing the former long-barrel Batterie guns. The heavy siege barrels were 24 calibres long. These guns were supported by 10-pdr howitzers. A 12-pdr could destroy a weak wall at 400 Schritte, but otherwise 24-pdrs were required for walled defences. In addition to the field methods, siege artillery used fire with a lowered barrel (or 'dominating fire', when the gun overlooked its target), *Stechschuss* (direct fire to damage fortifications at close range), *Prellschuss* (used to bounce balls off a vertical surface, so the ball did not embed itself), high angle fire to drop the round on a target and its counterpart, and shallow fire to hit the ground and ricochet upwards at the same angle. The guns could be fired with a full powder charge or, when using heated balls or ricochet fire, with reduced charges. Siege guns would be taken on campaign if expected to be required but would remain in the rear reserve park.

An 18-pdr *Vertheidigungs* cannon barrel made from cast iron. The barrel was 23 calibres long and its bore took up only a third of the total barrel width. (Abbildungen von kk Geschütze) (KA)

Hohe Wall-Lafette (high wall carriage) or casement guns, the lower being on a runner (1799). These guns were employed at the major fortresses: Josephstadt and Theresienstadt used 6- and 12-pdr bronze barrels, Königgratz and Olmutz had 6-pdr bronze barrels, and Temesvar used 12- and 18-pdr iron barrels. (Schleicher) (ONB)

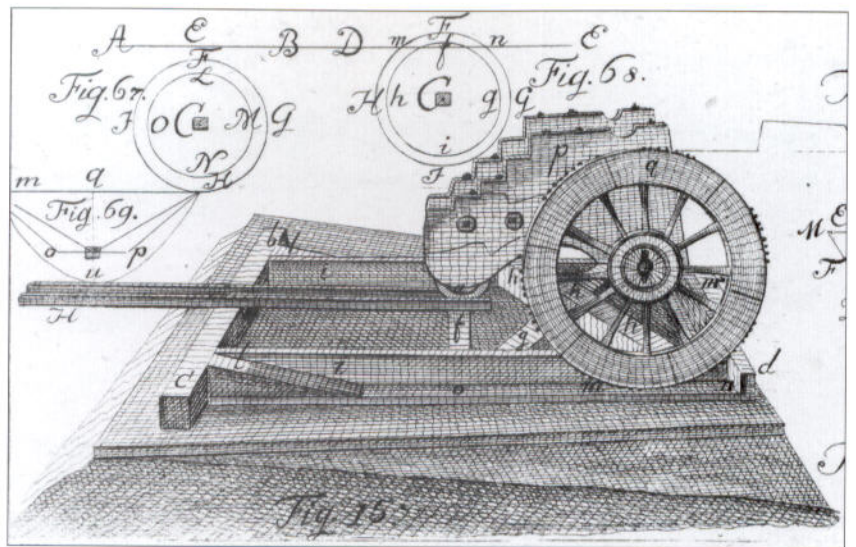

RIGHT *Verteidigungs* gun carriage and limber (1799). Unusually, this example uses thicker solid wooden wheels of the 54 Zoll diameter. The limbers for the siege and defence guns had 46 Zoll wheels and no ammunition box. The iron strap strengthening was only fitted to the end of the trail, the *Stirn* and around the trunnions. (Schleicher) (ONB)

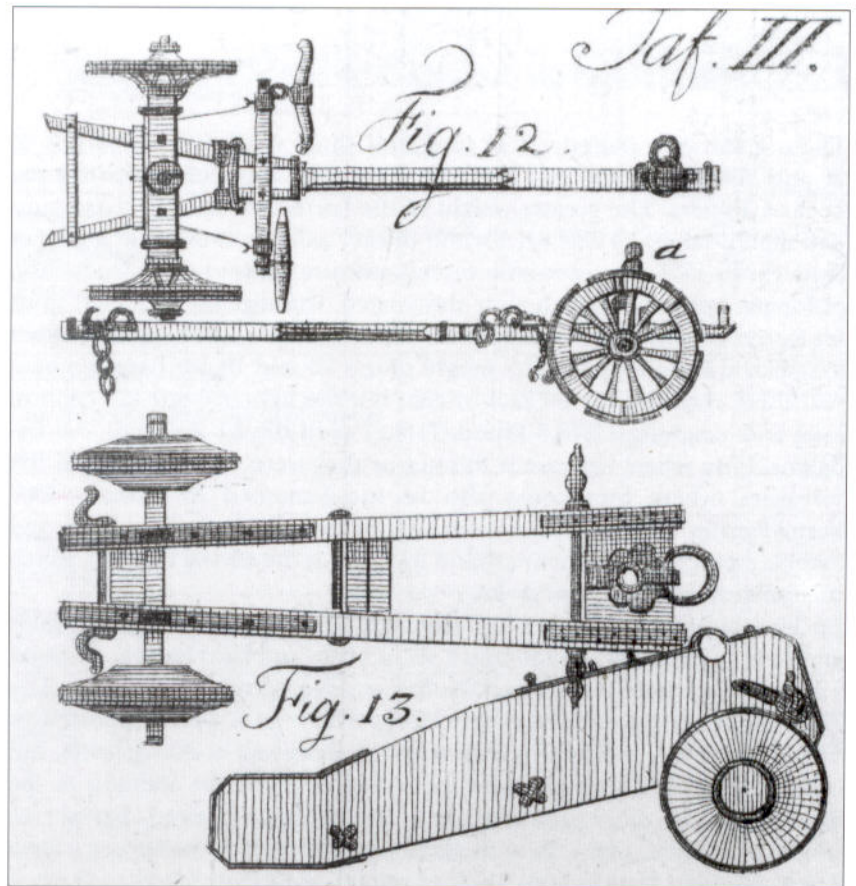

The heavy siege work was conducted with mortars, which had huge, short barrels of 10-, 30- or 60-pdr size, made of bronze and each of a standard 2.78 calibres in length. In 1794 Oberstleutnant Vega, a mathematics professor at the Bombardier School, directed 16 siege pieces including three 10-pdr howitzers to reduce Vauban's masterpiece,

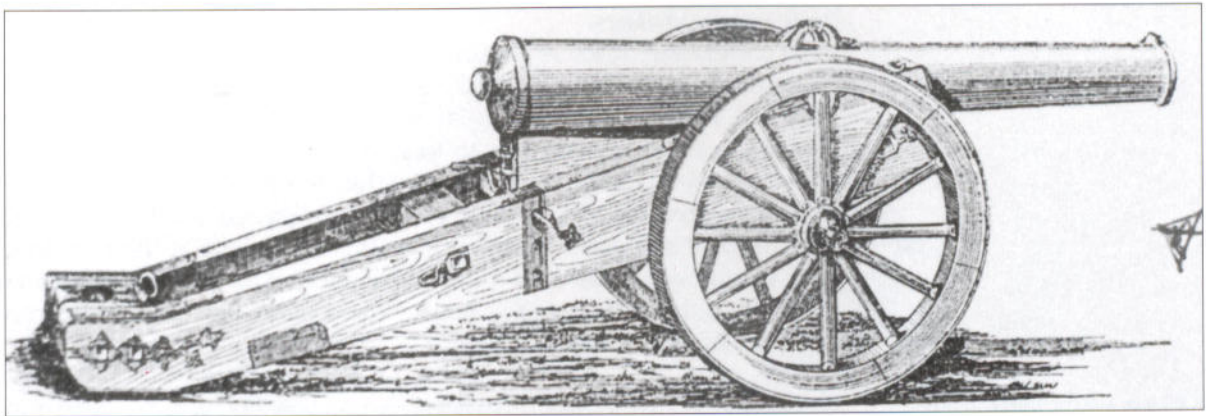

Fort Louis, in 24 hours. In 1796 he developed new 30-pdr and 60-pdr weitreibende *Mörser* (long-range mortars) and Mannheim fell to him after a seven-day pounding. Aligned at an angle of 45 degrees, the 30-pdr could propel a shell weighing 54.5 Pfund (30.5kg) for a distance of 2,250 Schritte (1.62km) using a 72 Löth charge; the 60-pdr had a range of 2,850 Schritte (1.8km) with a 109.25 Pfund (61.2kg) shell propelled by a 144 Löth charge. Enormous *Steinmörser* (stone-throwing mortars) remained in the inventory, but were rarely employed – there were two iron versions of 60- and 100-pdr size together with a bronze 120-pdr mortar. A small 6-pdr Coehorn mortar completed the inventory. The technical nature of mortars meant that their crews were composed of two Bombardiers and one, two and four Handlanger for the 10-, 30- and 60-pdrs respectively to carry the rounds.

ABOVE The simpler gun carriage still in use with the 1822 barrel. Verteidigungs barrels were made of iron to sustain the greater pressures on firing and were longer to provide greater range and accuracy. As they were rarely moved, the heavier iron was also preferred as a cheaper alternative to bronze. (Dolleczek)

BARREL LENGTHS (ZOLL (CM))

	6-pdr	12-pdr	18-pdr	24-pdr
Batterie gun (22 calibre)	–	115.35 (304)	127.08 (336)	134.42 (353)
Defence gun	94.98 (250)	115.45 (304)	122.3 (321)	–

During sieges, mortars and the heavy guns could fire solid shot which had been heated red-hot in ovens. The Austrians employed this technique at Lille in 1792 and during the siege of Valenciennes in 1793. At Valenciennes these rounds landed amongst French storehouses, causing an inferno which melted 14,000 muskets. However, the heating increased the size of the ball and made them harder to load, so shells were preferred. Heated rounds were also effective against fortifications constructed of green tree trunks, in which cold rounds tended to become entangled.

MORTARS AND 10-PDR HOWITZER SIZES AND SHELL DIAMETERS (ZOLL (CM))

	Bore	Shell Size (External)	Shell Size (Internal)
10-pdr	6.5 (17.1)	6.2 (16.3)	4.5 (11.85)
30-pdr	9.33 (24.6)	8.92 (23.5)	6.55 (17.25)
60-pdr	11.75 (31)	11.24 (29.6)	8.25 (21.7)

Gun manufacture

Most barrels were made of bronze, a mixture of 100 parts of copper with 10 parts of tin. Cast iron was used for the heavier *Verteidigungs* (defence/fortification) guns as it was stronger to sustain the larger charges, but was less resistant to wear than bronze. Wrought iron was already known to be a better material, but the production process was difficult and expensive. Guns were manufactured at Vienna, Graz, Prague, Pest and Hermannstadt (Brasov), but most were made at the foundries near Vienna and at Mecheln (now in Belgium). Iron guns were made at Mariazell and Reschitza in the Banat, where there were substantial iron and coal supplies.

A 60-pdr mortar barrel. These large mortars were used to fire stones and various large shells such as the *Stinkkugel*, in which powder was mixed with grated horsehoof, asafoetida (a type of smelly plant gum) and rotted cabbage leaves.



The basic shape of the barrel was first worked in moulds, some of which were lime, but most were sand, so it was easy to improve the shapes over time. Six men could cast a 12-pdr barrel from raw metal in five hours. The older ovens could handle 15–18,000kg of metal but needed 30–36 hours to melt it all down; the smaller ovens could melt 4–5,000kg but could produce molten metal in about four hours; the addition of 1,500 kg of boring scraps extended the process for an hour until the metal was ready for pouring into the moulds. The barrels could be removed from the sand moulds after 24 hours and 120–144 hours from lime.

The barrels were then bored out to half their widest diameter at the Imperial Bohrwerke at Mecheln and at Ebergassing near Vienna by wheels driven by water with a force of 6–8 horsepower, which turned the wheels 16 times a minute. The trunnions were finished off separately after the touchhole had been drilled. A 3-pdr required 20 hours of boring work, a 6-pdr 24, a 7-pdr howitzer 22 and a 12-pdr 28 to complete the process; the iron *Verteidigungs* 6-pdr required 30 hours and a 12-pdr 38 hours. Each bored barrel was then tested. First, it was closely examined, using a *Sterninstrument* (bore measuring device) to check the bore. Then, it was test-fired with 10 rounds or, for howitzers, three shots with a full charge. In addition, water was pumped into the barrel under pressure.

A: A regimental 3-pdr being moved forward with its ammunition box

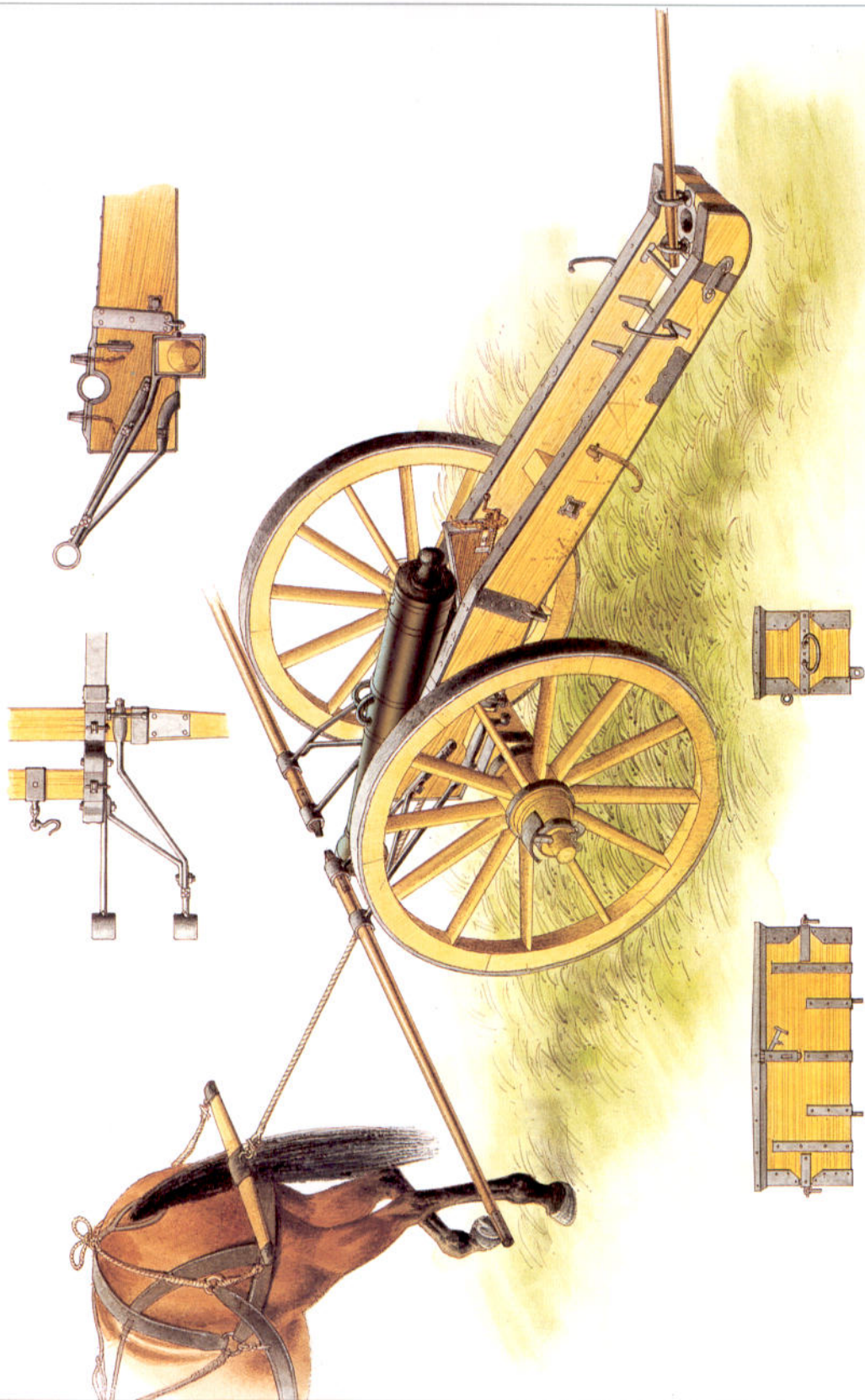

B: A 6-pdr cavalry gun with Wurst seat detail and part of the six-horse team

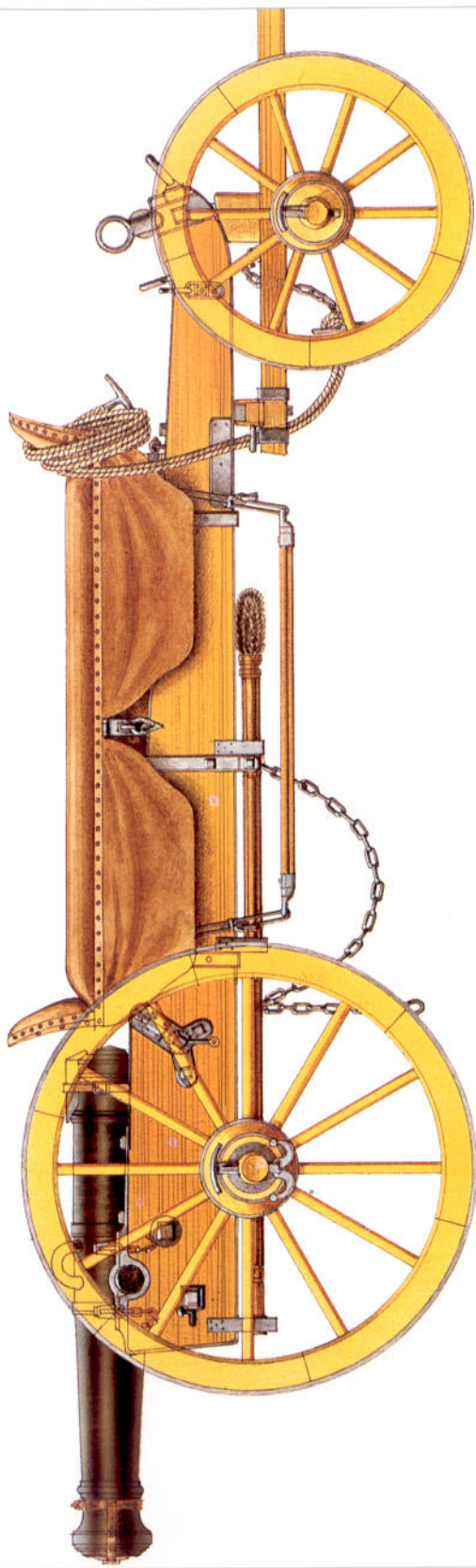
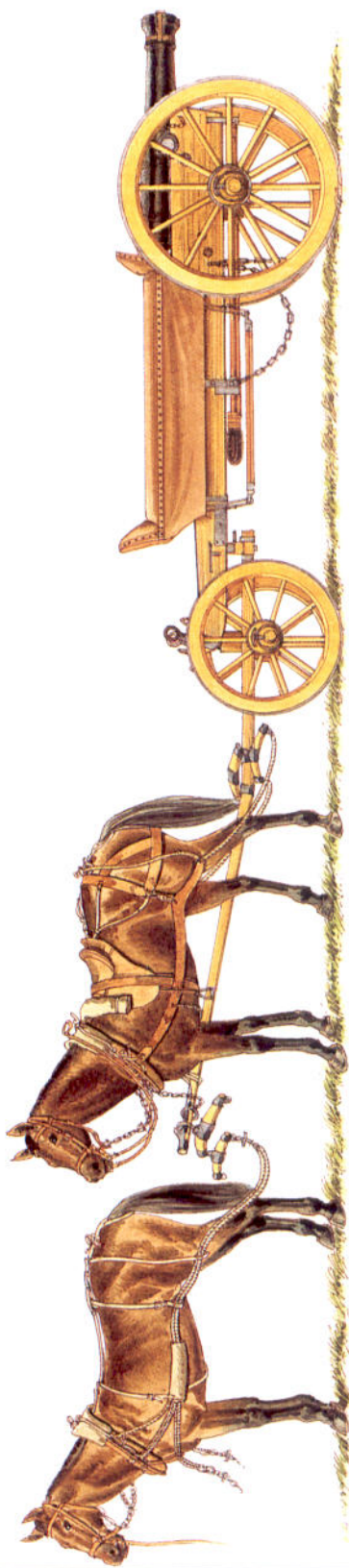

C: A 7-pdr Cavalry howitzer being repaired

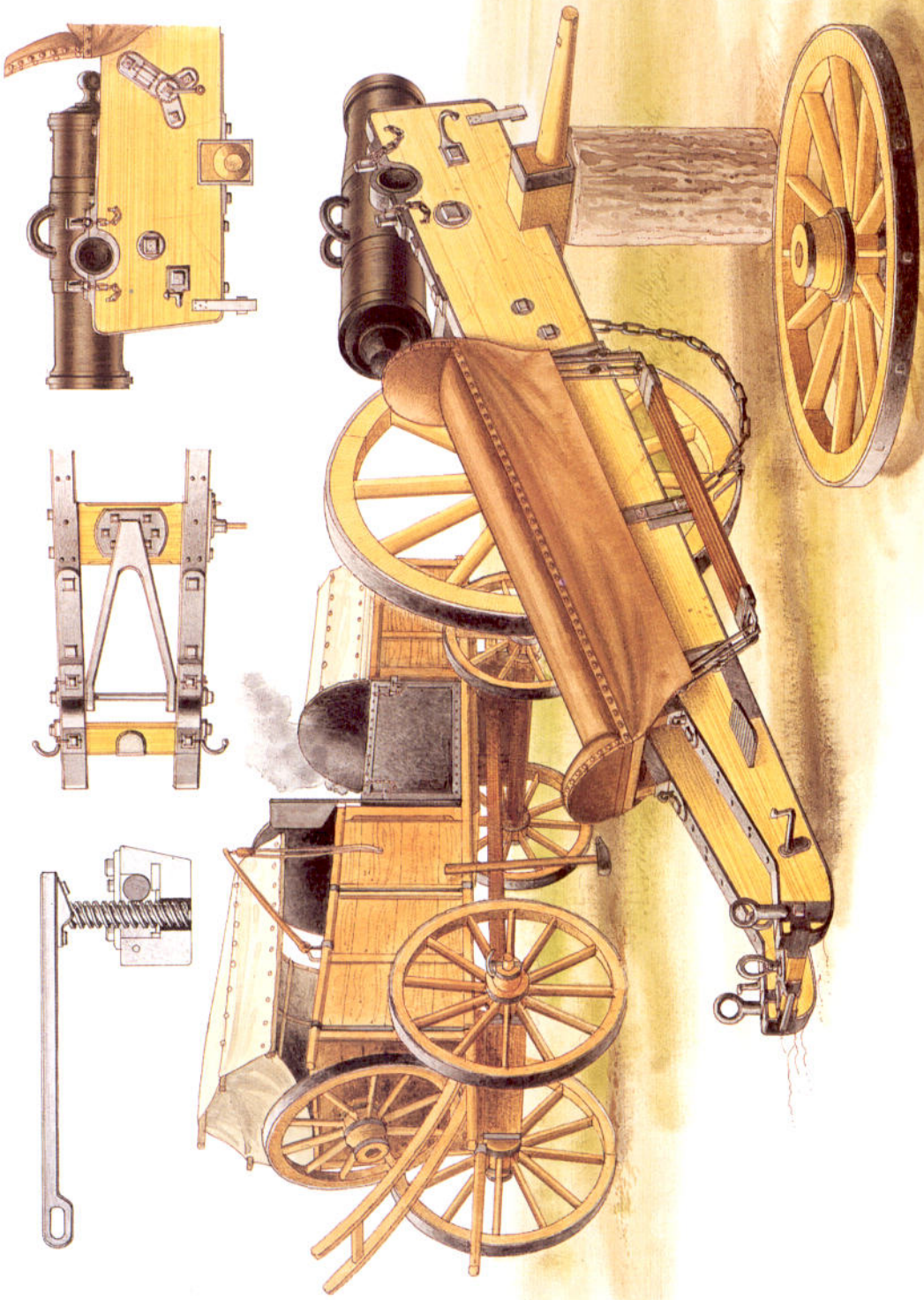

D: DETAIL OF A 6-PDR FIELD GUN

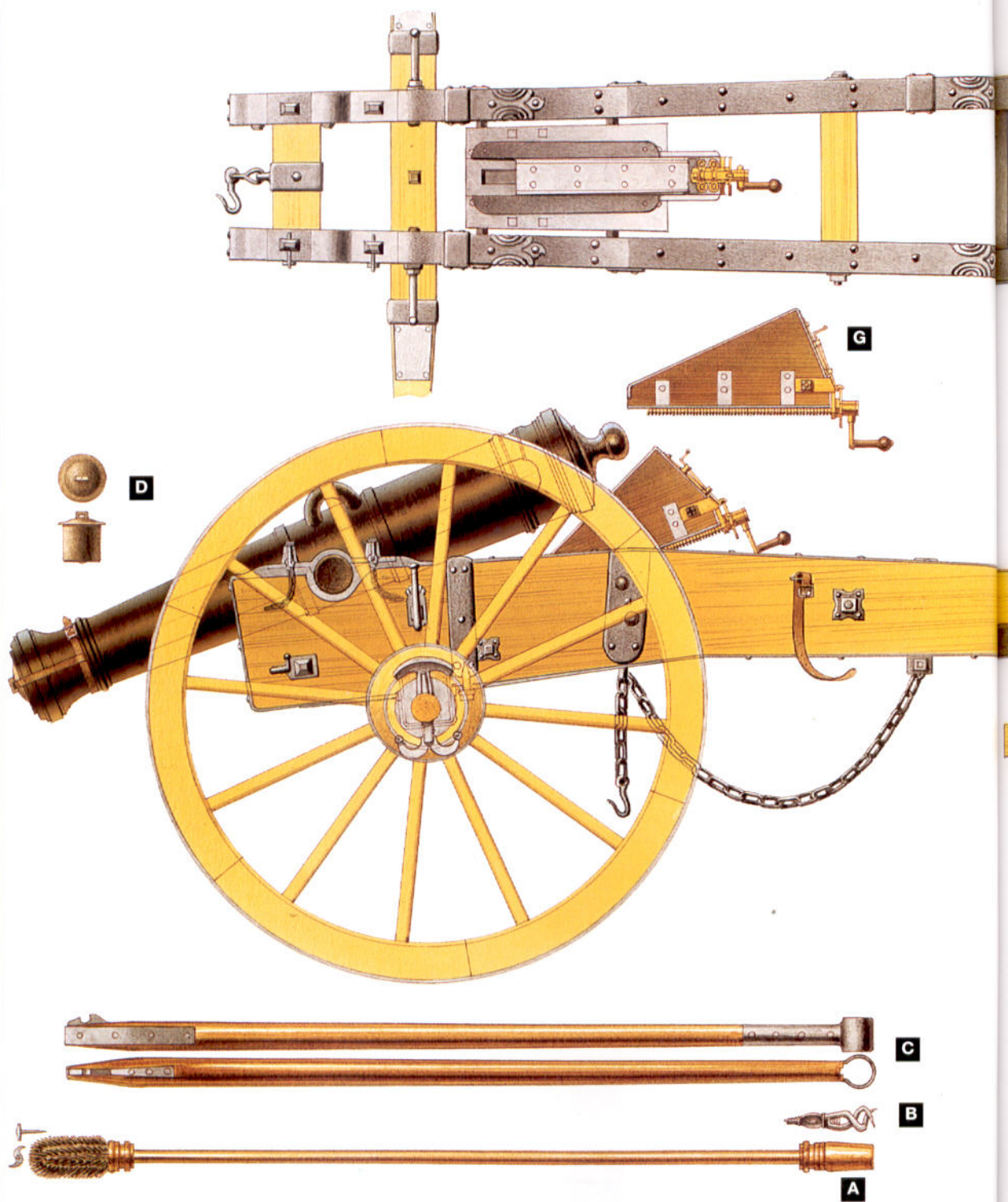

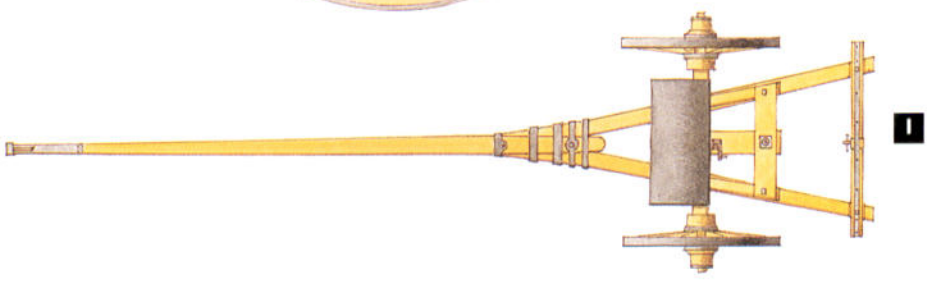
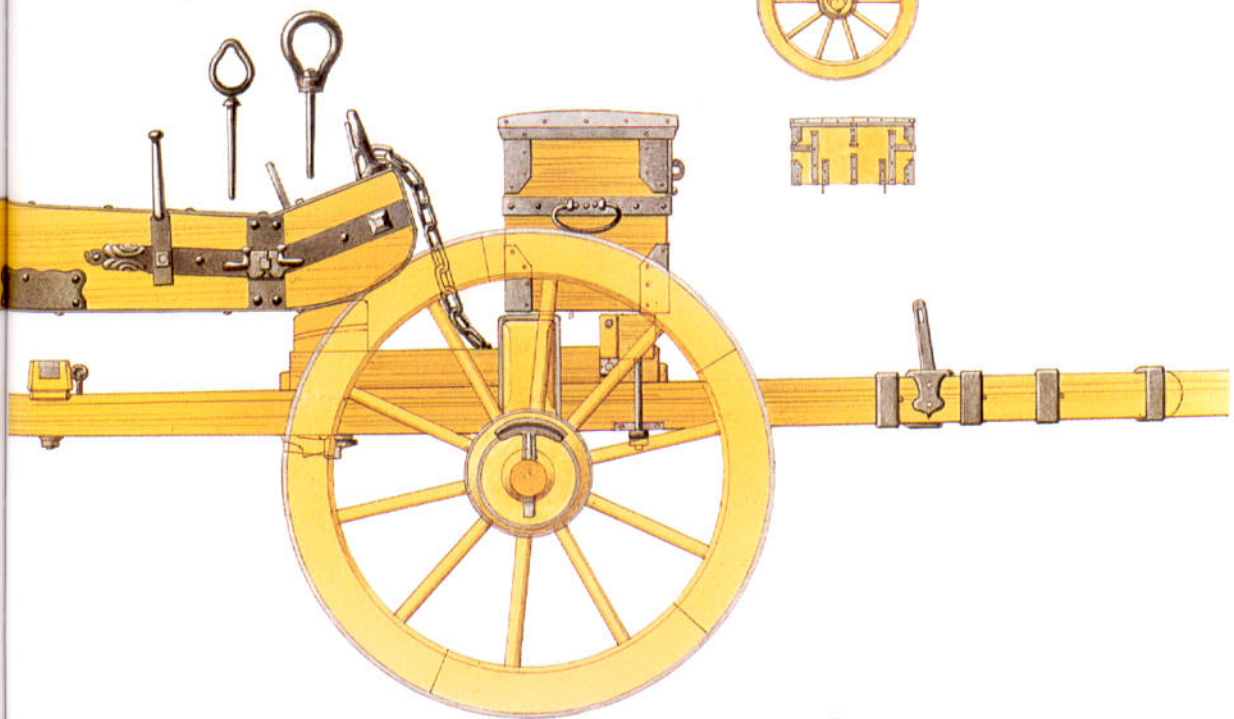
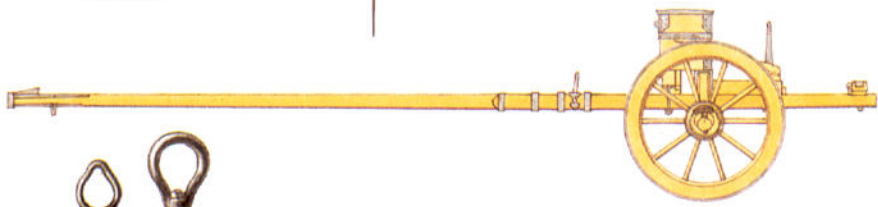
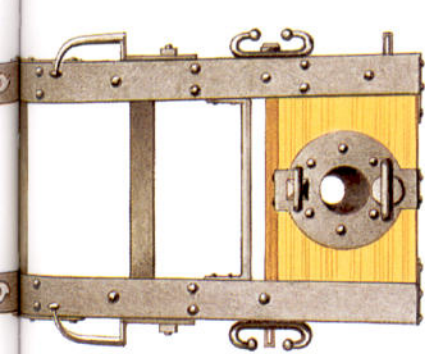

E: A 12-pdr Batterie (siege) gun in an improvised field fortification

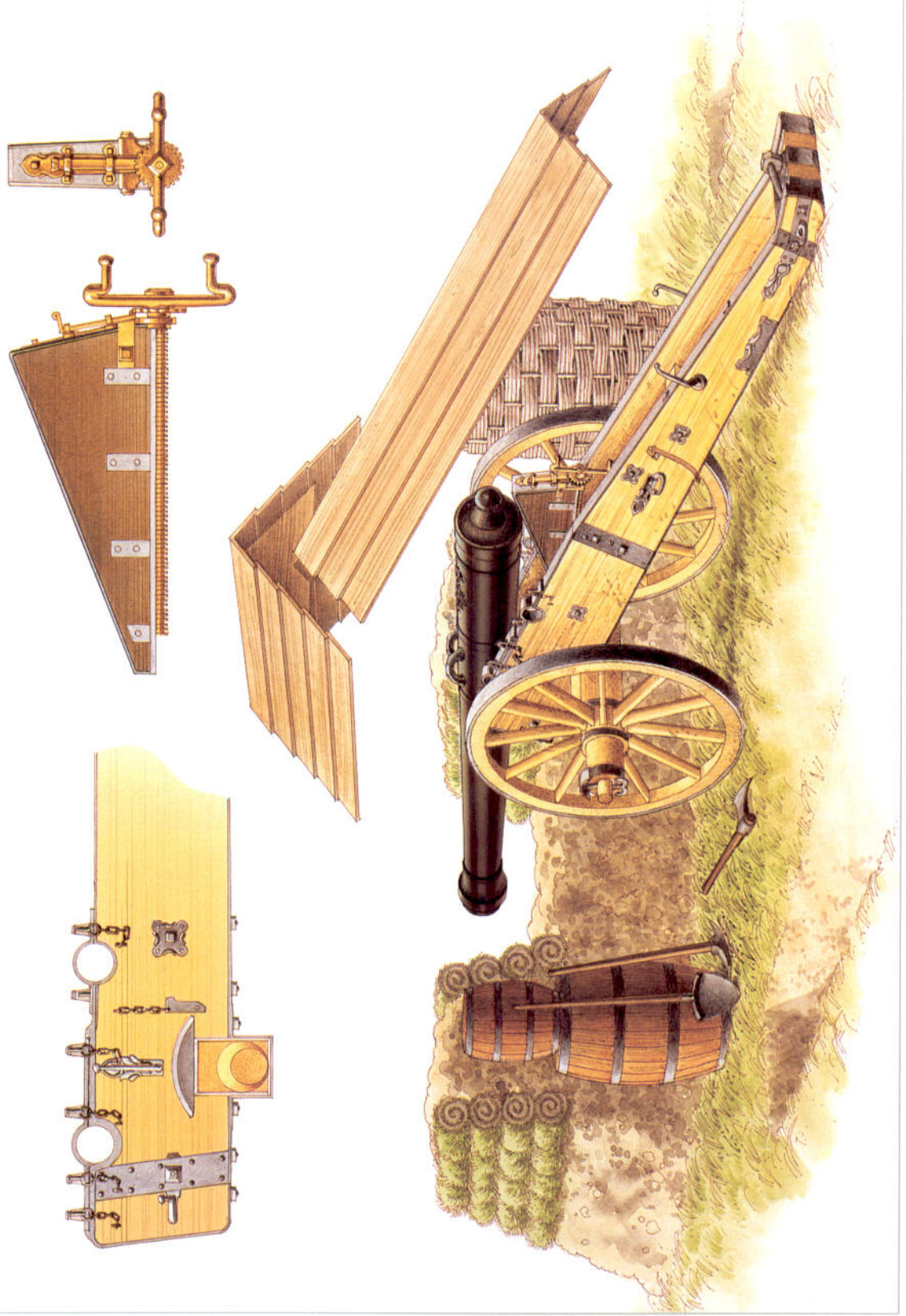

F: A tactical advance, based on Plate 45 of the 1807 Kavallerie Reglement

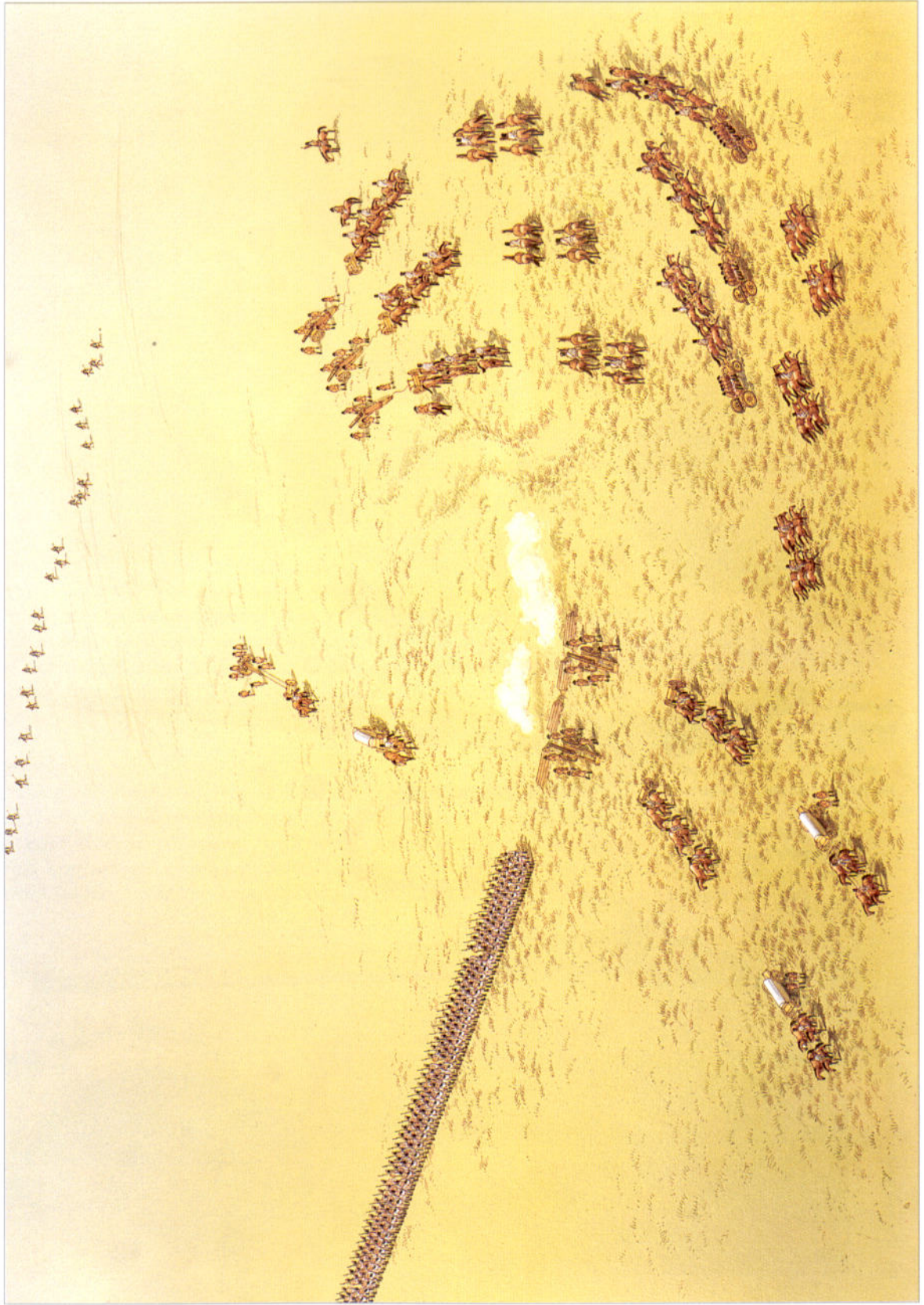

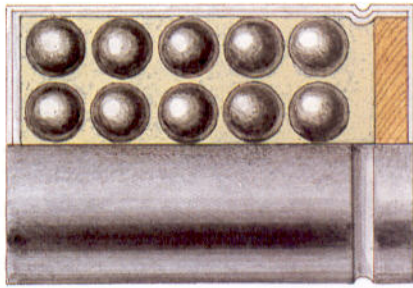
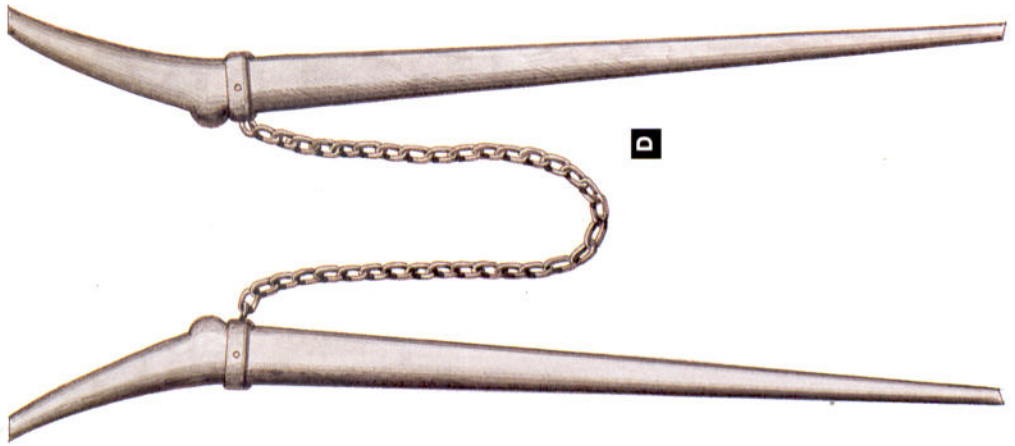
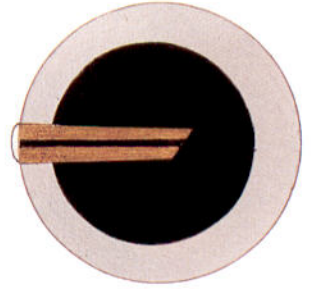
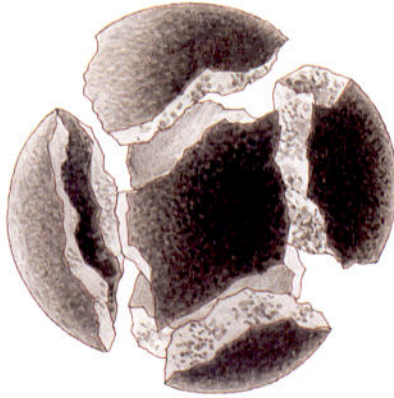
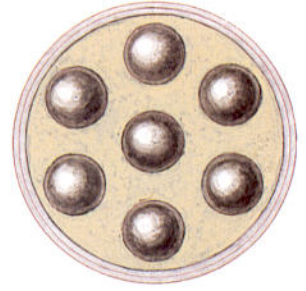
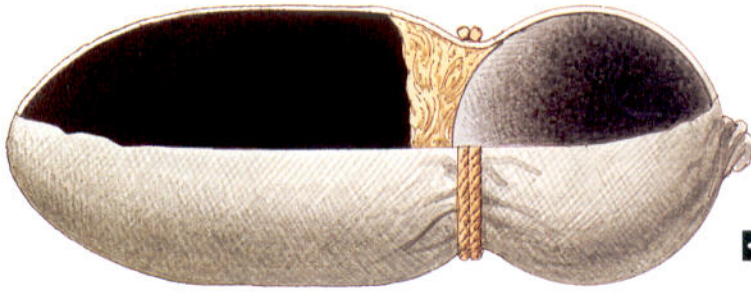

G: Ammunition types

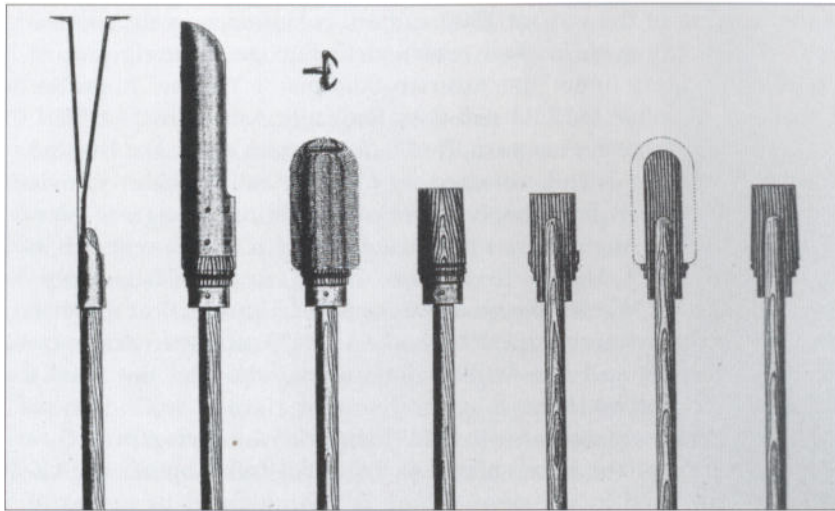

Ends of the tools to service a *Verteidigungs* gun. Left to right: two scrapers, the sponge, the rammer head (external and internal) and the internal design of the sponge. The front of the sponge has a small S-shaped scraper in addition to the six lines of bristles to remove material from the end of the bore.

The data obtained allowed an estimate to be made of the barrel's likely lifespan. In 1777 in Vienna, a series of tests assessed the wear of the barrels from firing. Three 24-pdrs fired 2,070 balls over a 17-day period and the barrels only expanded by about 2mm each. Four 6-pdr field guns fired 4–7,000 balls with full charges producing wear of 2.5–6.5mm. 4mm rendered them useless for field service. Generally, on field service, barrels would be worn out after 900–1,000 rounds. The 0.25 Zoll (6.5mm) touchhole would expand by about 2.6mm after 100 shots. As a result of these tests, few barrels split in action, but siege guns seem to have been more prone to this hazard. During the 1794 siege of Kehl, for example, five of the six 18-pdr and 19 of the 29 12-pdr siege guns burst, some around the barrel muzzle and some at the firing end.

Rockets

Following the British success at Copenhagen in September 1807, the General-Artillerie-Direktion ordered Oberfeuerwerker Mager to undertake trials of rockets in April/May 1808 near Vienna to create a battery comprising 24 rockets of 2 Zoll diameter (5cm). Unlike the British Congreve version, these rockets had tin tubes, but little more was

Watermill-powered boring machine of 1793 from Mecheln, Belgium. Horizontal boring had been in use for some time, starting in 1739, but vertical boring was only finally phased out in 1830. The loss of Mecheln to the French during the Revolutionary Wars severely reduced Austria's capacity to produce guns. (KA)

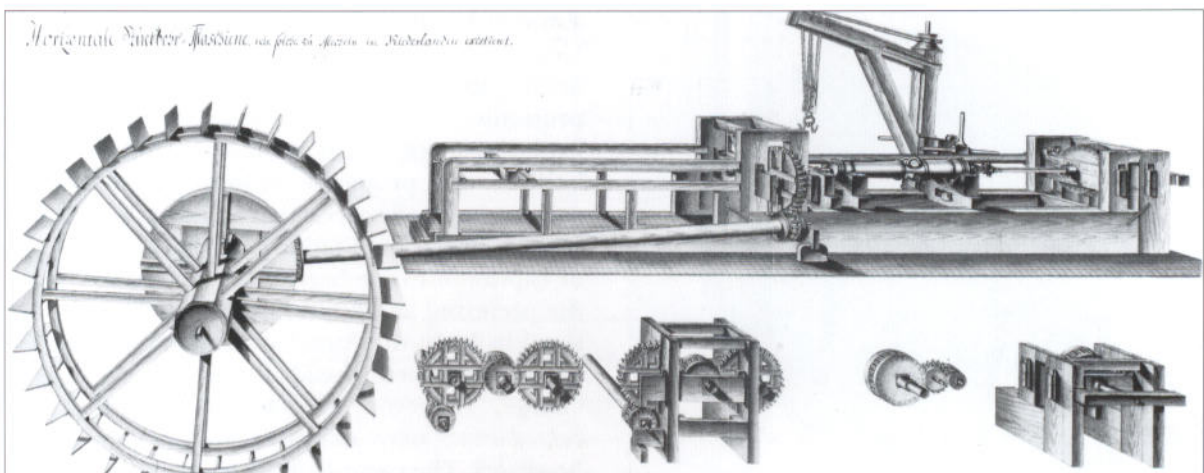

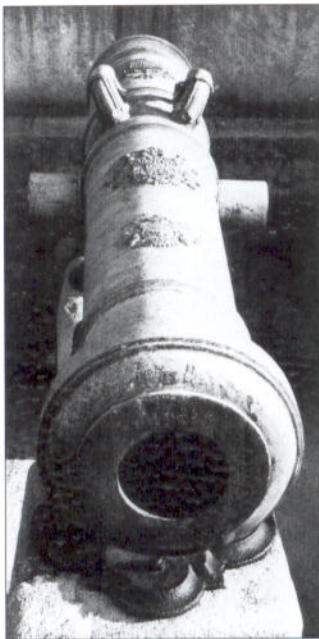

A 12-pdr barrel. From 1768 only the *Doppeladler* (double-headed eagle) crest was cast on the rear part of the cannon. A special crest would occasionally be cast on the front half, carrying a sponsor's arms. The trunnions were 4.32 Zoll in diameter.

A 6-pdr shot from the Aspern battlefield. Note the surface damage caused by a mix of the effects of the original casting and the firing process. (M. Baulesch)

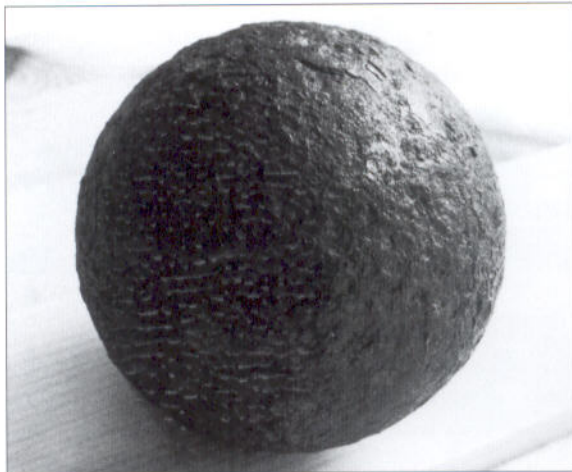

done because of the wars of 1809 and 1812. However, in the following year, British Congreve rockets returned to Europe, forming part of a combined battery under the Austrian Stabsmajor Vinzenz Augustin at Leipzig in October 1813. Ordered by Radetzky, Army Chief of Staff to resume trials, Augustin was permitted limited access to the Danish rocket factory on Hjelm Island, directed by Captain Schumacher, who had carried out further development work on the British Congreve system. Back in Austria, Augustin was instructed to begin rocket research and production on 2 March 1815. Two weeks later his laboratory at Steinfelder near Wiener Neustadt was open and production underway. On 16 May the first unit was established – 46 NCOs and men drawn from the Bombardiers and the Artillery Regiments, who had the need for secrecy impressed on them.

The rockets were divided into *Feld* (light field) and *Belagerung* (heavy siege). There were three sizes of rocket, 2, 3 and 4 Zoll diameter, the 4 Zoll design being used as the siege rocket. It was mounted by means of a square 5–6 Zoll width staff, which went through the frame supports and was attached to the rocket by a square housing. This was 9 Füsse (2.8m) long and came in two parts for easy transport. When required for use, the two parts were clipped together and the staff driven into the side housing. At the top sat a small shell, basically the same design as the howitzer shell with a *Brandrohr* fixed at the bottom. The tripod rocket frame weighed just 10.6kg and could be carried by one man.

A vehicle known as a *Wurstwagen* had been designed in 1810. This was essentially a four-wheeled ammunition cart with a *Wurst* seat (with a lower forward end, adopted on the Cavalry guns after the wars) on top, and a radical turntable style of axle mounting for the front wheels. By the time a full rocket battery of 2,400 rockets of varying calibres was ready for duty on 31 May 1815, the 12 heavy siege and 24 light field frames for launching the rockets were carried in 18 *Wurstwagen* with some ammunition, the rest being carried in ammunition carts. The rockets only saw action at the siege of Hüningen and were not very effective. The flat-firing range of a 6-pdr (2 Zoll) rocket was 250 Schritte, increasing to 1,200 Schritte with 25 degree elevation. A 12-pdr (3 Zoll) could reach 1,600 Schritte with a 30 degree elevation, but could veer off course and only achieved a 50 per cent hit rate against a 5.5 Füsse high, 90 Schritte target at 1,000 Schritte.

Ammunition

Most Austrian powder charges were assembled in linen bags which were secured directly on to the projectile, which sat on a sabot, so that the explosive force of the gunpowder was retained behind the projectile. The cartridges were painted in an oil-based mix of lead carbonate and varnish, which both reduced friction and the risk of explosion in the barrel. For close-range work, the preferred ammunition was a canister, a tin of small balls. In the Austrian Army, this was called *Kartätsche*, when already secured to the power charge. However, unattached rounds, called *Schrotbusche*, were allocated to the 3-pdrs and howitzers. The cartridges were kept upright in six

or eight compartments per ammunition box; 7-pdr howitzer boxes carried ten rounds, 10-pdr boxes just six.

The 3-pdr, 6-pdr and 12-pdr guns were allocated ball and canister ammunition. The Schrotbuchsens were also allocated to 3-pdr guns for emergency use or for greater effect, when they were loaded on top of a ball round. The 7-pdr and 10-pdr howitzers fired shell, illuminating shell and Schrotbuchsens. See Plate G for more information on ammunition types. The main field howitzer was the 7-pdr; the 10-pdr was usually deployed in siege work in support of the mortars, although it was used in the field in the early Revolutionary Wars. The powder charges for howitzers were separate because different charges were required for different ranges. The powder bag would be rammed into the narrower rear part of the chamber, which then widened to accommodate the round.

Loading shells required a special method. The charge cartridge was first rammed into the narrower part of the howitzer and then the barrel was aligned. The loader would then sprinkle some additional powder over the top of the Brandrohr and place the shell inside the barrel with the Brandrohr facing the charge, using the arm sleeve to protect his arm against the heat and embers in the barrel.

Ammunition storage

In 1774 the ready ammunition store was moved from the trail to a large box, made of softwood and mounted on the limber. Under the 1809 regulations, the limber box held:

	3-pdr	6-pdr	12-pdr	7-pdr howitzer
Ball rounds	12	–	–	–
3 Löth canister	12	9	6	–
6 Löth canister	–	9	–	–
32 Löth canister	–	–	6	–
Schrotbuchsens	8	–	–	2
40 Löth howitzer cartridge	–	–	–	45
Worming tool (in lid)	1	1	1	1
Vent pricker (in lid)	1	1	1	1
Touchhole nail	1	1	1	1
Square-head mallet	1	1	1	1
Padlock	1	1	1	1
U-bolt	1	1	1	1
Shovel	1	1	1	1

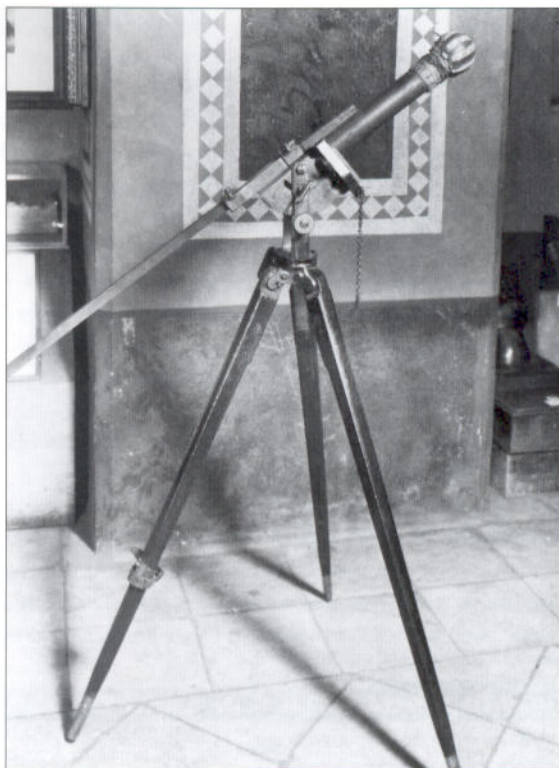

A 12-pdr rocket and launcher of the Augustin-Schumacher system, a development of the British Congreve system (see New Vanguard 65) and the Danish Schumacher version. Note the simple aiming device, an engraved semi-circular plate. The rocket troops' uniform was initially dark green. The tunic had black collars and cuffs piped red, brass buttons, and on both sides of the collar were brass burning grenade badges. Headgear was the shako with a large grenade badge. The heavier siege rockets used a reversed tripod. (BA)

Powder

Austrian powder, which had the reputation of being well manufactured and the strongest in Europe, was made exclusively by a state monopoly and private manufacture was forbidden. The actual mixture of saltpetre and minerals was decreed by the Pulver- und Salniterwesen, although it was conducted by artillery officers on the remoter garrisons. Under Feuerstein's 1756 regulation, the mixture was 70 parts saltpetre, 15 parts sulphur and 20 parts coal (75 parts, 12 parts, 13 parts for musket powder). The three constituents were worked together for 24 to 30 hours to create a coarse grain powder, using one of two water-powered mill processes: either in a *Walzmühle*, using rollers to grind the mixture, or at *Stampfmühle*, which crushed the mixtures. Although a *Walzmühle* required less power, its rolling method required more time and entailed greater risk of explosion. The powder was then dried in heated rooms or the open air.

The artillery bases had purpose-built accommodation barracks for the men; powder was stored in 4-storey magazines constructed in a 6-pointed star shape with the lowest floor below ground.



10-pdr shells used by the heavier howitzers and the lightest mortars. The fuse in a smaller mortar bomb burned 4 Zoll in 14 seconds; 4 Zoll would burn in 27 seconds for a larger bomb, such as the 10.42 Zoll fuse in a 60-pdr bomb.

POWDER QUANTITIES IN A CARTRIDGE (PFUND/KG)

	Ball	Canister
3-pdr	0.75 (0.4)	1 (0.6)
6-pdr	1.5 (0.8)	2 (1.1)
12-pdr	3 (1.7)	4 (2.2)

Effectiveness

There were several styles of fire. In the field, the emphasis was on the advantages of *Göllschusse* (ricochet fire) to extend both the range and effect of fire. Within a battery, the guns could be fired in rotation, although the emphasis was on concentrated fire against definite points.

Firing at a packed earth target, at 800 Schritte, the 3-pdr could penetrate 1.5m, the 6-pdr could penetrate 2.15m and the 12-pdr could penetrate 2.3 m (0.95 – 1.27m into oak). 6-pdr balls could pass through doors or light palisades easily at 400–500 Schritte (250–315m). Roundshot accuracy was acceptable out to 1,000 Schritte, where a company-sized target would take 40–70 per cent hits, but this reduced to 15 per cent at 1,500 Schritte. The 12-pdrs were effective to 1,200–1,400 Schritte, lighter pieces were effective to 800 Schritte. All ranges could be extended by 200 Schritte against dense formations. Tests were conducted at Ledenitz and near Vienna over several years, using a standard target of 6 Füsse high by 25 Schritte wide.

Austrian canister tests revealed the low percentage of hits with the balls at longer ranges:

At range of (Schritte/m)	475 (300)	554 (375)	712 (450)
6-pdr	7%	5%	Nil
12-pdr	5%	3%	2%
7-pdr howitzer	10%	6%	6%

EFFECTIVE RANGES (SCHRITTE (M))

(Ranges dependent on elevation)

Gun	Ball	Ball with ricochet	Canister type	Range
3-pdr	500–1,200 (315–760)	1,400–1,500 (885–950)	3 Löth	300–400 (190–255)
6-pdr	500–1,400 (315–885)		3 Löth	300–400 (190–255)
			6 Löth	400–600 (255–380)
12-pdr	500–1,600 (315–1,010)		3 Löth	300–400 (190–255)
			12 Löth	600–700 (380–440)
			32 Löth	900–1,000 (570–630)

The 7-pdr howitzer was judged a most effective area weapon. At 1,000 Schritte, tests produced 20–30 per cent hits from parts of the shell casing.

Using $\frac{1}{2}$ Zoll elevation, it could fire canister to a range of 400–550 Schritte and a 10-pdr's range was 450–600 Schritte. 40 and 60 Löth charges were rarely used for canister as the recoil damaged the carriage, but they extended the canister range to 700 Schritte for a 7-pdr with 40 Löth charge and an elevation of $\frac{1}{2}$ Zoll, while a 10-pdr with a 60 Löth charge could fire canister to 1,000 Schritte at an elevation of 1 Zoll.

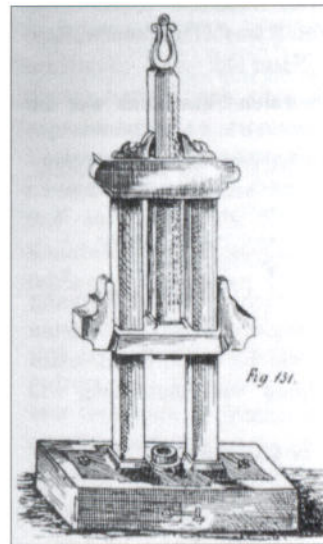

ABOVE From the 18th century, the strength of the powder was tested with a Stangenpulverprobe. In 1812 the French Probemörser with its large bronze counterweight was introduced. Water content was established by drying 100–200 grains at no more than 60 degrees C until they lost no more weight. (Above, Dollezek and below, surviving example)

FIRING SHELL

Gun/Charge	Elevation (Zoll)	Range (Schritte/m)
7-pdr		
16 Löth	0	100–500 (65–315)
	3.5–7	500–1,000 (315–630)
24 Löth	0	150–700 (95–440)
	3.5–7	800–1,400 (505–885)
32 Löth	0	250–900 (160–570)
	3.5–8	1,000–1,400 (630–885)
40 Löth	0	300–1,100 (190–695)
	3.5–7.5	1,200–2,100 (760–1,325)
10-pdr		
24 Löth	0	100–900 (65–570)
	3.5–6	500–900 (315–570)
36 Löth	0	150–1,300 (95–820)
	3.5–6.5	900–1,500 (570–950)
48 Löth	0	200–1,500 (125–950)
	3.5–7.25	1,000–1,800 (630–1,140)
60 Löth	0	250–2,800 (125–1,770)
	3.5–6	1,500–2,400 (950–1,520)

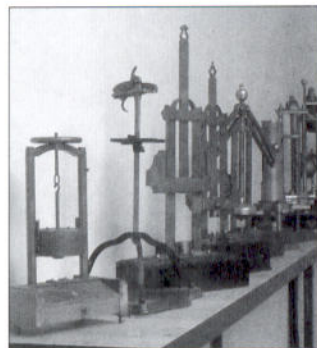

A mortar bomb being loaded. The short rope is run through holes on the side and the round lifted by several men. All mortars were mounted in a solid wooden box and angled with a flat wooden support. This is a slightly later illustration c.1820 with an 18-pdr Verteidigungs gun in the background. (Umhey)

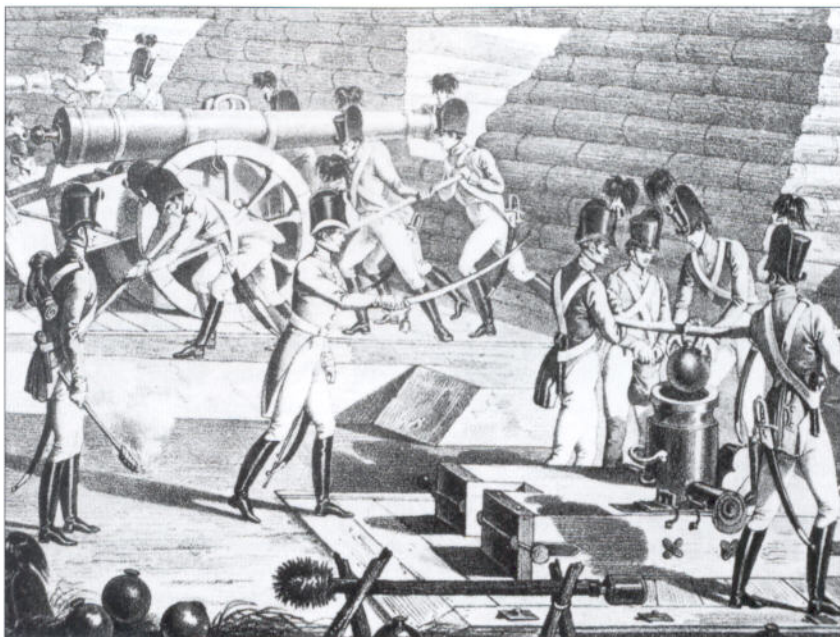

Wagons and packhorses

Lichtenstein also overhauled the wagons. The immediate reserve ammunition was carried in carts placed 30–40 Schritte behind the guns when in action. One two-horse cart was assigned to each 3-pdr and every two Cavalry pieces. The ordinary howitzers and the 6-, 12- and 18-pdr guns had a larger four-wheeled wagon with a four-horse team. Under enemy fire, one ammunition wagon present per pair of guns was regarded as sufficient, the others being placed under cover.

Horses and drivers were provided by the *Fuhrwesen* (transport unit), although establishing this usually entailed the rapid requisition of draught horses before the outbreak of war. The *Fuhrwesen* was manned by civilians, but was militarised in 1808. Horses were driven in pairs in the two- and four-horse teams. The leader of the six-horse team would also direct the centre pair. The four-horse wagon teams were driven from the front horse. (Klein) (Nürnberg Museum)



Under the 1809 regulations, the gun wagons were loaded as follows:

	3-pdr	6-pdr	6-pdr Cavalry	12-pdr	18-pdr
Ball	120	160	80	70	56
In no. of boxes	5	10	5	7	7
3 Löth canister	24	–	–	–	–
6 Löth canister	–	16	16	–	–
12 Löth canister	–	–	–	10	–
18 Löth canister	–	–	–	–	8
In no. of boxes	1	1	1	2	1
Brandrohren	200	250	200	130	120
Lighting tapers	50	50	60	50	50
In no. of boxes	1	1	1	1	1
4 Pfund roll of Lunten	1	1	1	1	1
Spare sponge/rammer	1	1	1	1	1
Horse drag rope	1	1	2	1	1
Carrying bag for rounds	2	2	–	3	3
Brandrohr bag & strap	1	1	–	1	1
Man drag line and strap	4	6	–	6	–
Schleppseil	1	1	1	1	1
36 Füsse Schleppseil	–	–	–	–	1
Worming tool	–	–	–	–	1
Vent pricker	–	–	–	–	1
Touchhole nail	–	–	–	–	1
Square-head mallet	–	–	–	–	1
Trunnion rollers (pair)	–	–	–	1	1
Lubricant (Pfund)	12	12	16	12	12
Limber spike	1	1	1	1	1
Horseshoes	4	8	12	12	12
Shoe nails	80	160	240	240	240
Rear traces	2	2	4	2	2
Forward traces	–	2	4	4	4
Kit box	1	1	1	1	1
Padlock	1	2	1	2	2

All items of equipment were marked with the gun's number. Every two guns carried a spare Schleppseil in an ammunition wagon. The six packhorses, which accompanied each Cavalry piece from the 1790s, carried large 2 natural brown leather bags down each side, one above the other. Each horse carried 20 rounds for a Cavalry gun and 10 shells for a Cavalry howitzer.

The howitzer carts were loaded as follows:

	7-pdr	7-pdr Cavalry	10-pdr
Shells	80	40	54
Schrotbuchen	10	10	6
In no. of boxes	9	5	10
Illumination shell	3	2	–
8 Löth cartridge	3	2	–
16 Löth cartridge	35	20	–
24 Löth cartridge	35	20	24
32 Löth cartridge	35	20	–
36 Löth cartridge	–	–	24
40 Löth cartridge	–	20	–
48 Löth cartridge	–	–	24
60 Löth cartridge	–	–	24
Box for cartridges and illumination shell	1 large	1 small	1
Shell ignition tubes	80	40	54
Brandrohren	140	120	100
Lighting tapers	50	60	50
In no. of boxes	1	1	1
4 Pfund roll of Luntten	1	1	1
Canvas pouch with 4 Pfund of powder	2	1	2
Spare sponge/rammer	1	1	1
Horse drag rope	1	2	1
Carrying bag for rounds	3	4	3
Brandrohr bag and strap	1	–	1
Arm sleeve	1	–	1
Man drag line and strap	6	–	–
Schleppseil	1	1	1
Worming tool	–	–	1
Vent pricker	–	–	1
Touchhole nail	–	–	1
Square-head mallet	–	–	1
Lubricant (Pfund)	12	16	12
Limber spike	1	1	1
Horseshoes	6	12	8
Shoe nails	120	240	160
Rear traces	2	4	2
Forward traces	2	4	2
Kit box	1	1	1
Padlock	2	1	2

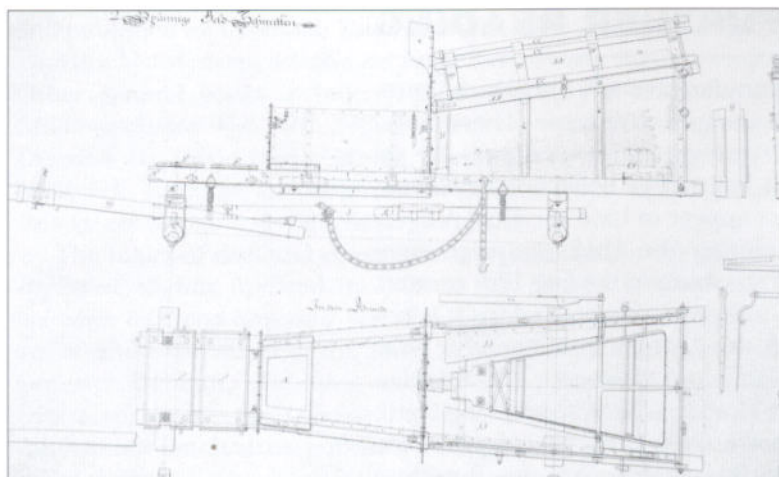

Two-wheeled field smithy with 51 Zoll wheels. An empty two-horse ammunition cart weighed 999 Pfund and a four-horse version 1,284 Pfund.

Four-wheeled wagon with 46 Zoll wheels at the front and 51 Zoll wheels at the rear.

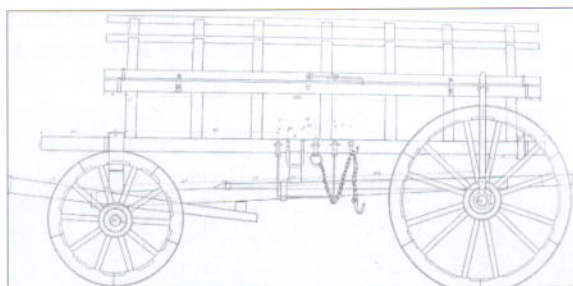

In action, the immediate reserve ammunition wagons would be replenished by a steady stream of wagons moving from the reserves, the two-wheeled type being used more frequently for its greater speed. The immediate *Unterstützungsreserve*, behind the second *Treffen* (battleline), comprised about a quarter of the ammunition – $\frac{1}{4}$ was on two-horse wagons and $\frac{1}{4}$ on four-horse wagons. The main *Hauptreserve*, behind the army, held half of the ammunition of which two thirds was on two-horse wagons and one third was on four-horse wagons. The *Schwere Reserve* held $\frac{1}{4}$ of the ammunition held one to two days' march behind, which was replenished by bigger wagons bringing ammunition from the magazines.

The allocation of ammunition for each gun from the immediate reserve was approximately:

Guns	Ball	Canister	Schrotbuchen	Shell	Chainshot
3-pdr	90	12	2	–	–
6-pdr	94	26	–	–	–
12-pdr	123	40	–	–	22
6-pdr Cavalry gun	94	26	–	–	–
7-pdr howitzer	–	–	12	72	–

The larger ammunition wagons were about 50 per cent larger than the smaller versions:

WAGON DIMENSIONS

	2-wheeled	4-wheeled
Length along the base	68 (179)	104 (274)
Width across the base	27.5 (72.4)	30 (79)
Width across the top of the sides	30 (79)	40 (105.4)
Height of the sides	15 (39.5)	22 (57.9)
Highest point of the lid	71.5 (188.3)	78 (205.5)
Turning circle (Füsse/m)	25.34 (8)	43.34 (13.7)

COLLECTIONS AND FURTHER READING

Only one gun has survived – a 6-pdr manufactured in 1814, which is now displayed in the Landeszeughaus Museum in Graz, Austria. There is also a 1753 barrel mounted on an earlier carriage and several tools are on display. The Army Museum in Vienna has a large collection of barrels, although no other carriages or limbers appear to have survived. A 6-pdr and a 6-pdr Cavalry gun captured during the 1812 campaign were recorded in the Army Museum in St Petersburg in the late 19th century, but do not appear to have survived. Both were painted red, so it is not certain whether they were taken from the Austrian contingent or were re-used French–Allied guns (probably Saxon). However, 180 Austrian barrels from that campaign are still in Moscow – 10 × 12-pdr, 70 × 6-pdr, 71 × 3-pdr guns and 29 × 7-pdr howitzers. Only 4, 24, 18 and 4 of these respectively can be seen in the Borodino Museum, the Borodino Panorama and in part of the Kremlin Arsenal, as the remainder are in the restricted access part of the Kremlin. Earlier patterns can be seen in the Esterhazy castle at Forchtenstein in eastern Austria.

The main books in English are the recent general surveys: Duffy, *The Army of Maria Theresa* (reprinted 1990) and *Instrument of War* (2000), which cover the 18th century wars, together with Rothenburg, *Napoleon's Great Adversary: Archduke Charles & the Austrian Army 1792–1814* (reprinted 1995). G. Nafziger, *Imperial Bayonets* (1996), is a comparative survey of all the main nations.

Other sources

General background information comes from the histories of the four Artillery Regiments, together with the Staff Histories: *Osterreichische Erbfolgekrieg (1740–1748)*, *Kriege unter Joseph II*, *Krieg gegen die Franzosische Revolution*, *Krieg 1809*, *Befreiungskriege 1813–14* and the Prussian Staff History of the 7 Years War, Smola's papers were collected



ABOVE Barrels outside the Army Museum in Vienna. Left to right: 60-pdr mortar (1756), two 7-pdr howitzers (1765 and 1759), 3-pdr (1770), two 6-pdrs (1761 and 1764), 12-pdr (1768).



LEFT A large gun (probably an 18-pdr field gun), being moved with an eight-horse team in 1813. Some illustrations suggest that the pieces of the wheel were strengthened by the addition of metal plates at the joins.

and published in: C. Smola, *Taschenbuch für kk öst. Artillerie-Officiere. Teilweise nach den hinterlassenen Schriften des Joseph Freiherrn von Smola* (Vienna 1822). Other general books include: J. Zimmerman, *Handbuch zur deutschen Militärgeschichte*, Vol. III: *Militärverwaltung und Heeresaufbringung in Osterreich bis 1806* (1965); Wrede, *Geschichte der kk Wehrmacht* (Vol. 5); Dolleczek, *Geschichte der österreichischen Artillerie* (reprinted 1970); Gallina, *Beiträge zur Geschichte des öst. Heerwesens* (1872).

The basics of drill and operations are contained in the 1757 *Artillerie Reglement*, slightly updated in 1809 in the *Exercier Vorschrift mit dem kk ordinaren Feld- und Kavallerie Geschütze sowohl einzeln als in Batterien*. There are several manuals from the time, although their drawings tend to be generic: Demian, *Anleitung zum Selbst – Studium der militärischen Dienstwissenschaft für Officiere der k.k. österreichischen Armee* (1807); Anonymous (an Austrian gunner), *Die Regeln der Placirung des Geschützes im Felde, als Versuch einer systematischen Zusammenstellung derselben* (1808). The 1767 *Die Artillerie Lehre* concentrates on geometry, but is a useful source of technical figures. Hauser, *Die Artillerie*, is particularly useful for howitzer information. Technical drawings are held in the *Kriegsarchiv* in Vienna.

Later published articles include: Semek: 'Die Artillerie in 1809', *Mitteilung des Kriegsarchiv*, Series 3, Vol. 7; Boltek, 'Das KK Cavallerie Geschütz', *Mitt des Kriegsarchiv*, Series 1, 1885; Unterberger, 'Nötigste Kenntnis von dem Geschütz und dessen Gebrauch', Nemetz: *Die Kriegsraketen im öst Heere*, *Mitteilung des ost. Staatsarchiv* X, 1957.

For repair or changing, heavier barrels were lifted using a **Hebzeug**, which comprised three or four legs and a pulley system. (Hochle c.1820) (Umhey)



GLOSSARY

Besteck – Tool for clearing the touchhole vent and pricking the powder charge

Brandkugel – Large illumination shell fired from mortars

Brandrohr – Shell ignition fuze (also Schilfrohrbrandrohr)

Deichselstangen-Tragstrick – Drag rope for horses attached to the hook on the *Stirn*

Feuerwerkskasten – Howitzer wagon for carrying specialist equipment and shells

Fuss – Austrian measurement (approx. Imperial foot)

Göllschusse – Ricochet fire to extend range

Handlanger – Untrained labourers assisting gunners

Hebbaum – Pole for lifting Cavalry pieces at the rear

Hebzeug – Frame for lifting barrels from carriages

Kartätsche – Canister round with powder charge attached

Lafette – Gun carriage

Leuchtkugel – Illumination shell

Lichte – Short tapers for rapid fire in place of *Zündrute*

Löth – Austrian measurement (approx. Imperial ounce)

Lunte – Slow-burning rope on the *Zündrute*

Mörser – Mortar

Mundklotz – Barrel bung

Pfund – Austrian weight (approx. 1 pound or French Livre)

Prellschuss – Style of shot to bounce off vertical surfaces

Protzbaum – Traversing spar to align the gun

Raumnadel – See *Besteck*

Richtsmaschine – Aiming screw to set the barrel angle

Schleppseil – Long rope run from the limber for field movement (equivalent of the French *Prolongue*)

Schrotbuchse – Canister tin with no charge attached

Sperrschusse – Chainshot for anti-battery fire

Stechschuss – Style of siege fire for direct fire

Stossplatte – Iron base of a *Leuchtkugel*

Stirn – Front crosspiece of the *Lafette*

Transmissionsrichtmaschine – Aiming system of a Cavalry gun or howitzer

Traube – Backweight counterbalance on a barrel

Treffen – Army battle line

Vormeister – Gun captain

Zoll – Austrian Measurement (approx. Imperial inch)

Zundlochcappe – Touchhole cover, also to secure the barrel end for transport

Zündrute – Fuse igniter (or port fire)

COLOUR PLATE COMMENTARY

A: A REGIMENTAL 3-PDR BEING MOVED FORWARD WITH ITS AMMUNITION BOX

The 3-pdr's short barrel meant that the end of the barrel was exactly in line with the front of the 51 Zoll standard wheel. The 3-pdr was essentially a smaller version of the 6-pdr, although its limber box differed slightly in its fittings. In line with the trunnions, the inner width of the carriage was 8.45 Zoll (6-pdr 9.5 Zoll) to accommodate the barrel. At the back, the inner distance inside the walls was 11.25 Zoll (6-pdr 13 Zoll). The distance from the centre of the trunnion cut to the front was 7.75 Zoll (6-pdr 9.15 Zoll). The distance from the centre of the trunnion support to the shoulder was 19.25 Zoll (6-pdr 24.25 Zoll).

The front drag rings protruded up at an angle of about 45 degrees to the front, so that the rings were above the barrel. They supported two drag bars, each of which was pushed on by two men. These 6 Füsse bars were pointed on the inner ends closer to the barrel and could be used to shift the gun if it became bogged down. For the main power, a horse was taken from the limber, but it was normally connected to the limber bar attached to the limber cross-piece. This bar could not be unhooked, so the *Deichselstangen-Tragstrick* (drag rope), which connected up to the hook on the *Stirn* (front of the carriage), also had its own limber bar, to which the horse's chain harness could be attached.

B: A 6-PDR CAVALRY GUN WITH WURST SEAT DETAIL AND PART OF THE SIX-HORSE TEAM

The seat was made of wood, covered with a plain reddish brown leather cover on the main part of the seat, and the cover nailed round the edge. The seat, which was set back 37.5 Zoll from the *Stirn* at the front, was stuffed with horsehair.

It was 63 Zoll long, 15 Zoll high in the main part of the seat, and 10.75 Zoll wide at the front and rear. The drop-down footrests were made of wood with a metal mounting plate fitted at the rear. Hard up behind the barrel end, the seat made it impossible to use the usual aiming device or to have a counter-weight on the end of the barrel. In the Wurst seat box was stored the immediate use ammunition and so there was no ammunition box on the limber, which was otherwise the same as for the ordinary guns.

The gun itself was essentially the same as the 6-pdr with a longer trail, but no backweight (*Traube*) on the barrel. The barrel was strapped down with a white *Zundlochkappe* (strap), which had iron fittings and doubled as a protective cover for the touchhole. The trail was 130.5 Zoll long, the extra length of 25.75 Zoll being in the main part of the trail. Its heights were 12 Zoll at the front and 6.15 Zoll at the back. In line with the trunnions, the inner width was 9.5 Zoll to accommodate the barrel. At the back, the inner distance inside the walls was 14 Zoll. The distance from the centre of the trunnion cut to the front was 8.6 Zoll. The distance from the centre of the trunnion support to the shoulder was 24.25 Zoll, as for an ordinary 6-pdr. It only had drag hooks at the front. The trail end ring arrangement was different from the ordinary guns, as there were an additional two rings set across the trail end for lifting the trail from the limber.

The sponge-rammer and two traversing spars were supported underneath on the bars, which ran right across, while at the front there was a square hook wide enough to accommodate the sponge-rammer and then a traversing spar

Gun crew sitting on the trail of a 12-pdr. (Klein) (Nürnberg Museum)



which was hooked on; the other traversing spar was strapped on. The axle was the same 5 Füsse 6 Zoll size with a 51 Zoll wheel as in the standard 6-pdr, but the outer parts of the axle were narrower and set slightly back from the centre of the wood axle block. The main difference with Cavalry pieces was the aiming apparatus, the *Transmissionsrichtmaschine*, which worked from the left side with a handle, which turned to move a screw which raised a V shaped platform with the open ends to the front. These ends were secured to the carriage wall but further forward than in the usual aiming system plate.

When limbered, the Schleppeil rope was wrapped around the rear of the gun. Only the left side rear horse saddled and a right side unsaddled horse in the second line with traces going ahead to the front horses are shown from this six-horse team. At the front of the limber was a hook, which accommodated the ring to secure the central bar for the middle two horses.

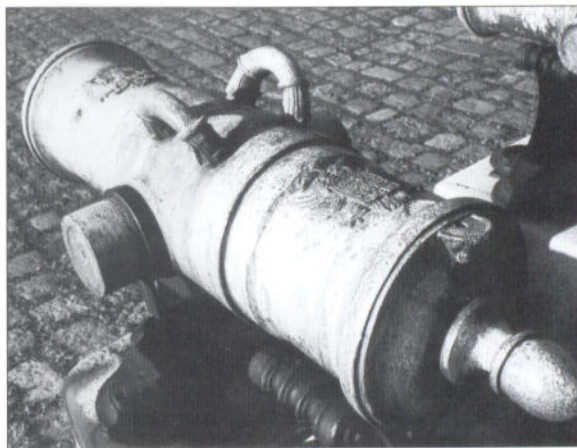

A 7-pdr howitzer barrel. The wider bore extended as far as the rear end of the thicker part.

COMPARATIVE WEIGHTS (PFUND/KG)

	6-pdr		7-pdr howitzer	
	Ordinary	Cavalry	Ordinary	Cavalry
Barrel	692 (388)	690 (386)	490 (274)	490 (274)
Carriage	710 (398)	777 (435)	788 (441)	861 (482)
Wurst Seat	-	123 (69)	-	128 (72)
Limber	463 (259)	327 (183)	442 (248)	327 (183)
Ammunition	157 (88)	108 (60)	101 (57)	158 (88)
Men	-	650 (364)	-	520 (291)

C: A 7-PDR CAVALRY HOWITZER BEING REPAIRED

The barrel of this weapon was exactly the same length, 35 Zoll, as that of the ordinary 7-pdr, and the muzzle for both was in line with the Stirn. The gap between the walls at the trunnions was 10.2 Zoll. The carriage was 125 Zoll long, thus 20.6 Zoll longer than a normal 7-pdr howitzer, with a height at the front of 15.1 Zoll (as for a normal 7-pdr howitzer) and at the rear 6.5 Zoll. In line with the trunnions, the inner width was 10.2 Zoll to accommodate the barrel. At the back, the inner distance inside the walls was 12.3 Zoll (normal: 12.1 Zoll). The distance from the centre of the trunnion cut to the front was 9.4 Zoll (normal: 10.5) to counterbalance the heavier trail.

This gun had the same arrangement of drag hooks at the front and rear as for the 6-pdr gun in Plate D. The arrangement for the underneath support of the tools was the same as for the 6-pdr in Plate B. The axle was the same standard pattern.

The Wurst seat had slightly different dimensions from the 6-pdr gun, as it only carried four men. It was 57.5 Zoll long, 16.5 Zoll high in the main part of the seat, 10.15 Zoll wide at the front and 11.25 at the rear. It was set 36.5 Zoll back from the front of the carriage. The seat precluded any use of the normal aiming mechanism, so this was moved to the side. This *Transmissionsrichtmaschine* operated by means of a handle at the side of the gun, close up to the seat. The barrel was sat on a V-shaped support secured at the front almost in line with the trunnion inserts and coming to a point, which was located above the vertical screw, so that this carried the thickest part of the barrel at the rear. The vertical screw moved up and down through a metal block, which was open at the base, so that the

barrel could drop below horizontal. It was operated by moving against a horizontal screw worked by the exterior handle. The greatest elevation was 18½ degrees for the howitzer barrel compared with 15½ degrees for the 6-pdr barrel.

In the background is a 4-wheel field forge. Its wheels were the 6-piece 51 and 5-piece 36 Zoll types. The forge was protected by an off-white linen cover. The metal furnace was painted black and the bellows were worked by the lever to the left. The total weight when empty was 1,380 Pfund (773kg).

D: DETAIL OF A 6-PDR FIELD GUN

The barrel handles are in the simpler post-1780 style. There were three metal ties towards the rear, which fixed on via the narrow plate running along the outside of the trail on its lower edge. The *Lafette* (carriage) was 104½ Zoll long and its walls were 3 Zoll thick. The carriage is shown as after 1808 when the drag rings were removed. The sponge/rammer and the *Protzbaum* (traversing spar) hooked on to the upper support just above the axle with the other ends on the lower support. They were secured in the centre with a leather strap.

The wheels were 6-piece with an iron rim and measured 51 Zoll in diameter. The limber's securing mechanism was also simplified. Note the small chain, which hooked into the back ring on the carriage when limbered up, and took both of the eyes at the end of the Schleppeil when the gun was moved using that rope.

Equipment

A) The sponge/rammer. The sponge was made of stiff horsehair bristle fixed in six rows with an S-shape worming tool on the end. **B)** The large worming tool which could be screwed into the rammer head. **C)** The *Protzbaum* (traversing spar) had a hook end for passing through the two rings at the end of the carriage. The 12- and 18-pdr guns and 10-pdr howitzers had a T-end so that two men would use the bar and also carried a *Hebbaum* (lifting pole), which was passed through the swivelled ring to lift the trail on to the limber. **D)** *Mundklotz* (barrel bung). **E)** The charge was fired by the *Schilfrohrbrandrohr* (fuse tube), which was inserted into the ¼ Zoll wide touchhole. It was made of tin and pre-filled with powder. The tin container was open at



A 6-pdr barrel. Two surviving examples from the 1760s show a discrepancy of 6cm (2.3 Zoll) in length. The trunnions were 3.44 Zoll in diameter and this 1761 example has the older style, elaborate handles.

the bottom but came encased in paper, which was penetrated with the pricker just before it was inserted into the touchhole. **F)** The Zündrute (lighter) was 2 Füsse 6 Zoll long, carrying burning Lunte of 0.5 Zoll diameter. 1 Fuss of Lunte would burn for 3¼ hours.

G) The *Richtsmaschine* (aiming mechanism) was a screw system, the block being made of wood and the fittings from brass and iron. The screw would be turned by a handle, moving the block along the central axis of the gun. The rear end of the barrel was supported on the block and so the barrel could be raised or lowered by moving the block by the screw working through the loop at the right hand end. The barrel rested on the top of the block and when the gun was being readied for fire the Handlanger at the end of the barrel would lean on it to make the movement of the *Richtsmaschine* easier. The Empire's financial difficulties meant later models were entirely iron-mounted. The *Richtsmaschine* on the sole surviving 6-pdr, dated 1814, is angled so that its top edge is horizontal. This is because its support is made from thick wood and the outer slide is also made from wood.

H) *Besteck* (or *Raumnadel*) – vent clearer/powder bag pricker, for clearing the vent and pricking the cartridge.

I) The limber was a standard piece for the lighter guns, measuring 15 Füsse 3 Zoll (4.82m) in length, constructed from elm or beech. The 12-pdr limber was 7 Zoll (18.4cm) longer from the axle. The wheels of the 6-pdr limber were smaller versions of the main design, measuring 36 Zoll (94.82cm) in diameter and made of five pieces, giving a clearance from the lower axle edge of 16 Zoll (42.14cm).

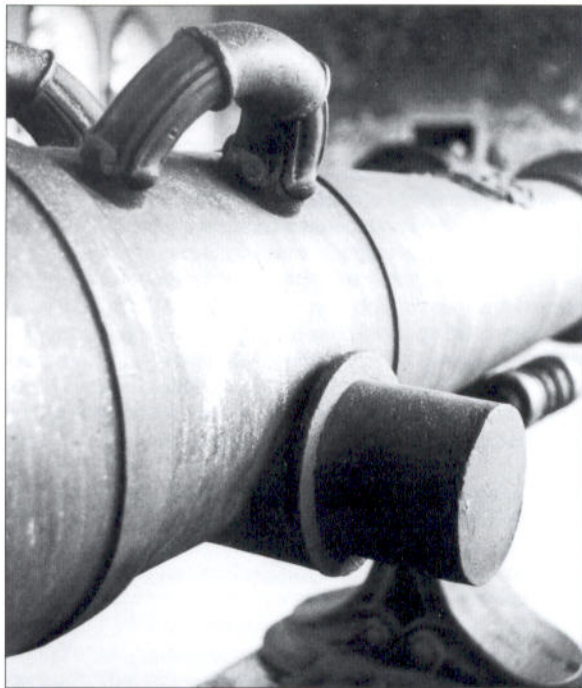

Details of the central part of a 12-pdr barrel. The handles are of the older 1753 style and the barrel has strengthening rings on either side of the handles and trunnions. Rollers around the trunnions enabled it to be moved between the inserts.

E: A 12-PDR BATTERIE (SIEGE) GUN IN AN IMPROVISED FIELD FORTIFICATION

To the front, are a gabion and two barrels, the smaller being a powder barrel, to protect the position, which is made of earth banked up and stabilised with rolled turf. Smola recommended that 0.65m deep trenches were dug to the sides to protect crews from incoming fire. The working frontage for these guns was at least 14–16 Füsse, but this could be reduced to 10–12 Füsse in field fortifications.

This 12-pdr gun barrel was 22 calibres (115.35 Zoll) long and was made of blackened bronze. Its *Traube* (backweight) measured 7.15 Zoll. All carriages for heavy 12-pdr guns and larger had two inserts for their barrels' trunnions: one to the front for firing and one to the rear for movement. The carriage, which measured 180 Zoll long, was in the same style as for the field guns, but the heavier barrel required a thicker axle – its centre width and height being 7 × 9 Zoll. The outer parts of the bearing were 6.8 tapering to 4.75 Zoll. The aiming device was bigger and heavier than for a field gun with a double handle.

Above the gun is a *Wetterdach*, a two-piece wooden roof covering the barrel/wheels and the trail to protect them against the weather. In windy areas, the *Wetterdach* had to be secured to the gun. Each was made of a pair of frames, which were supported on shaped wooden pieces, so that the *Wetterdach* could sit on part of the gun.

F: A TACTICAL ADVANCE, BASED ON PLATE 45 OF THE 1807 KAVALLERIE REGLEMENT

Cavalry guns move up to attack a French line from the flank, while two 12-pdrs remain in position and 3-pdrs lead the

infantry advance. The Austrian line has begun its advance from a position protected by a couple of 12-pdrs in a temporary fortification. A 3-pdr is up ahead, but has come under enemy skirmish fire and is now pulling back. Coming up on the flank is a Cavalry artillery battery, which has its first half (3 × 6-pdrs) in action and the second half coming up (1 × 6-pdr and 2 × 7-pdr howitzers). The 6-pdrs are firing across the French line to maximise their effect. Behind the 12-pdrs are the limbers with six-horse teams and two ammunition wagons.

The retiring 3-pdr is being withdrawn on the 22 Füsse Schleppeil, so that the trail is about 1.5 Füsse off the ground and the traversing spar is through the smaller ring and out at 70 degrees.

The first three Cavalry guns are already up and unlimbered, but attached to the 22 Füsse ropes. The packhorses are another 20 Füsse beyond the main horse team.

G: AMMUNITION TYPES

Roundshot A) The ball was cast in the normal way in foundries and then reheated and forged to render the surface tough and smooth. The sabot wadding was made of wool off-cuts (*Stoff*) or cowhair. The cartridge round was made of linen for the heavier siege and defence weaponry, but wool fabric for the field guns, secured with light brown string to

targets. In fact, for men, they were best at half man-height and for buildings, they needed to go through the roof and explode at ground level for maximum effect. The 7-pdr's firing charge was the same diameter as a 3-pdr and the 10-pdr was the same as a 6-pdr, the length depending on the charge weight/range required.

Kartätsche (Canister) C) This was made of sheet tin with a wood base between the tin bottom and the part where the canister narrowed. The top was similar with a thinner wooden disc and above a tin sheet lid. The narrower part allowed the round to be secured against the cartridge with the sabot formed by the wooden disc. Canister was used with varying sizes of ball, which were packed inside with sawdust. At close range, smaller lead balls were used and often loaded in pairs with a Schrotbuchse loaded on a Kartätsche round. At longer range and for wooded and uneven terrain, larger iron canister was preferred as it was less prone to distortion on discharge and the ricochet effect was improved.

The 3-pdr's Kartätsche and Schrotbuchsen contained 30 × 3 Löth balls. The 6-pdr used a light canister of 60 × 3 Löth balls and a heavy version of 28 × 6 Löth balls. The 12-pdr used three types: a light canister with 120 × 3 Löth balls, a medium version containing 28 × 12 Löth balls and then a heavy canister filled with 12 × 32 Löth balls. The 7-pdr and 10-pdr howitzer used Schrotbuchsen containing 6 Löth balls, numbering 67 and 120 respectively.

Sperrschusse (Chainshot) D) Made in a rounded form, the two bars were 3.5 Füsse (1m) long and 2 Zoll (5cm) at the widest point. The chain had 36 links and measured 3 Füsse (36 Zoll). Chainshot was mainly used as an anti-battery weapon.

Leuchtkugel E) The illuminating shell was oval-shaped with a widest width equal to that of the equivalent shell for the 7- or 10-pdr howitzers which fired them. The 7-pdr shell was 8.5 Zoll high and the 10-pdr was 9.5 Zoll high. Three pieces of elliptical canvas were sewn together to form the basic bag, which had a net of thin ropes around it, pulled together to form the handle at the top. The bag held a mixture of 2pds of saltpetre, 3pds of sulphur, ½pd of coal, 1pd of resin and 1pd of antimony, so that after the initial ignition at the top, it burned slowly for three minutes.

The bag was placed inside a linen bag, which was covered with pitch and tallow and at the base was a hollowed-out rounded piece of iron (*Stossplatte*). At the top was a thicker tubular iron ring and up the sides were five layers of string, the tops of which were pulled together to form a ½ Zoll wide hole at the top where the ignition charge was fitted. The ignition charge was similar to the shell Brandrohr with a fuse-filled wood tube. This was lit a few seconds before firing, as the shells were launched with the *Stossplatte* facing the charge. The bore therefore had to be dampened down with earth or water before firing to prevent early ignition. As a large charge would destroy the shell, the 7-pdr used an 8 Löth charge and an elevation of 13 degrees, so that the *Leuchtkugel* travelled a range of 500 Schritte (316.8m) after a 13 second flight after which it would burn for approximately three minutes. A 10-pdr used a 12 Löth charge and a 12 degree elevation to throw the shell 550–600 Schritte (350–380m). Larger projectiles, known as *Brandkugeln*, were fired from 30- and 60-pdr siege mortars and incorporated small tubes in a spiral around the projectile, which held small iron balls.

BALL SIZES, WEIGHTS, CHARGE DIAMETERS

	Diameter (Zoll/cm)	Weight (Pfund/kg)	Charge (Zoll/cm)
3-pdr	2.73 (7.19)	2.45 (1.37)	2.76 (7.27)
6-pdr	3.43 (9.03)	4.90 (2.74)	3.52 (9.27)
12-pdr	4.32 (11.38)	9.82 (5.5)	4.42 (11.64)

hold the slightly narrower ball against the sabot and charge. The material was then drawn round the ball and twisted off.

Shell B) The shell was filled with powder and the metal would break into about six parts on detonation. The 7-pdr shell measured 5.5 Zoll in diameter and the hole was 0.78 Zoll; the whole shell actually weighed 12.75 Pfund. Inside, the chamber was 4 Zoll in diameter, and the case was thicker at the bottom (0.85 Zoll) and thinner to the top (0.65 Zoll) with a slightly flattened base. Ignition was provided by a wooden Brandrohr, which was filled with fuse composition, which was usually a mixture of 3 parts black powder, 2 parts saltpetre and 1 part sulphur. More powder produced a quicker burn time, but extra sulphur slowed it. Until a Brandrohr was used, a plaster plug protected its top. The tube was made of very smooth hornbeam wood and, for the 7-pdr shell shown here, was 5 Zoll long. It could then be cut for the required time of up to 38 seconds before detonation, the cut being made at an angle. The 10-pdr howitzer shell measured 6.2 Zoll outside and 4.5 Zoll inside and weighed 18.25 Pfund; its Brandrohr measured 5.5 Zoll. Ideally, the shell would explode at about half man-height in the open and at ground level when used against buildings, so that it could be fired through the roof. (Popular wisdom is that shells exploded above their

- aiming 14, 46
 Cavalry guns 45
 preferred targets 8–9, 47
 rockets 35
- ammunition 24, 34–5, 47, **G**
 6-pdrs **34**
 10-pdrs **36**
 heated 23
 howitzers 23, 35
 mortars 23, 24
 storage and wagons **16, 19, 35, 38–41, 41, 44, A**
- arsenals 10
- artillery
 allocation 4–9
 organisation 9–10
 strength 4
- Aspern-Essling, battle of (1809) 9, 34
 Augustin, Stabsmajor Vinzenz 34
 Austerlitz, battle of (1805) 9
 axles 17, 20, 21
- barrel handles **18, 45, 46, D**
- batteries
 brigade batteries 6–7
 Cavalry batteries 6, 7, 19
 composition 14
 Position batteries 5, 6, 7
 Reserve batteries 4–5, 7
 size 3
- Bombardiers 10–11, 13, 19
 Bombardier school, Rennweger
 Kaserne **11**
- brigade batteries 6–7
- Cavalry batteries 6, 7, 19
 Colloredo, Joseph 6
- drill 8, 10, 43
- elevation angles and methods 16, 36–7
 howitzers 45
 mortars 23
- Feuerstein 20
 field forges 45, **C**
 field smithies **41**
 fire, style of 8, 21, 36
 firing 13–14, **13, 45–6, 47**
 rate 14
 recoil 14
 touchholes **7**
- Fort Louis, siege of (1794) 22–3
 fortifications, field 46, **E**
 Frierenberger, Maj. 9
 frontage 5
 fuses 36
- Gribeauval, Jean Baptiste de 15
- gun carriages 17–18, **22, 23, 45, 46, D, E**
- guns
 1747 system **6**
 disabling 9
 effectiveness 8, 36–7
 Lichtenstein system 3, 15–16
 lifespan 33
 loading 13, 35
 manufacture 10, 24–33, **33**
 positioning 8–9
 protecting from weather 46, **E**
see also firing; transport
- guns, battalion 5, 6
- guns, casement **22**
- guns, Cavalry 4, 7, 18–20
 6-pdrs **19, 44–5, B**
 wagons 38–9
- guns, field
 3-pdrs **5, 6, 18, 42, 44, A**
 6-pdrs **4, 15, 16, 17, 42, 45–6, 46, D**
 12-pdrs **16, 18, 34, 42, 44, 46**
 18-pdrs **42**
- guns, siege and defence 20–3, 24
 12-pdrs 46, **E**
 18-pdrs **21, 38**
- horses and drivers 12, **12, 38–9, 38, 42, 44–5, B**
 Cavalry guns 19–20
- howitzers 3, 7
 7-pdrs **12, 16, 42, 45, 45, C**
 ammunition 23, 35
 Cavalry artillery 18–20, **19**
 deployment 5–6
 moving **12**
 operation 13
 wagons 38–40
- Kehl, siege of (1794) 33
- Lichtenstein, Prince Josef Wenzel 4, 5,
 10, 12, 15, 38
- Lieberwolkwitz, battle of (1813) 9
 lifting frames **43**
- limbers 17–18, **18, 19, 22, 45–6, B, D**
- Lodi, battle of (1796) 14
- Mannheim, siege of (1796) 23
 Marengo, battle of (1800) 9
 Messkirch, battle of (1800) 9
 mortars 22–3
 60-pdrs **24, 42**
 ammunition 23, 24
 loading **38**
- Neerwinden, battle of (1793) 9, **13**
- Perczel 3
 personnel
- administration 10
 field artillery 9–10
 garrison artillery 10
 gunners 4, **10, 11–14**
 handlers 4, 6, 12–14
 mortars 23
see also Bombardiers
- Position batteries 5, 6, 7
- powder 34–5, 36, 47
 supply 10
 testing **37**
- ranges 8, 36–7
- Rennweger Kaserne **11**
- repair 10
 howitzers 45, **C**
- Reserve batteries 4–5, 7
 rockets 3, 7, 33–4, **35**
- Rouvroy, Feldmarschall-Leutnant
 Freiherr von 18–19
- Schleppseil rope 17–18, 45
 Schumacher, Captain 34
 seats and seat boxes 3, **19, 20, 44, B**
 howitzers 45, **C**
- siege warfare *see* guns, siege and
 defence
- Smola, Oberst C. 3, 7, 8, 9, **13, 46**
- Stein, Oberst 9
- tactics 4–9, **14, 46–7, F**
- tools **33, 45–6, D**
 bungs 4, 45, **D**
 sponge-rammers **16, 17, 19, 33, 44, 45, B, D**
 traversing spars **15, 18, 44–5, B, D**
 vent prickers **10, 46, D**
- touchholes **7**
- training 8, 10–11, 12, 19
- transport 13, 17–18, **42, 44–5, A, B**
 Cavalry guns 19–20
 howitzers **12**
 personnel 6
- uniforms
 artillery crew **10**
 rocket troops 35
- Valenciennes, siege of (1793) 23
- Vega, Oberstleutnant 22–3
- wagons 34, 38–41, **41**
- weight
 ammunition 47
 guns 15, 45
- weights and measures 3
- wheels **15, 17, 17, 21, 22, 41, 45**
- windage 15
- Wurzburg, battle of (1796) 9

The design, development, operation and history of the machinery of warfare through the ages.

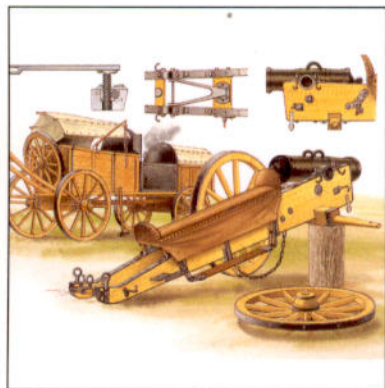

Full colour artwork

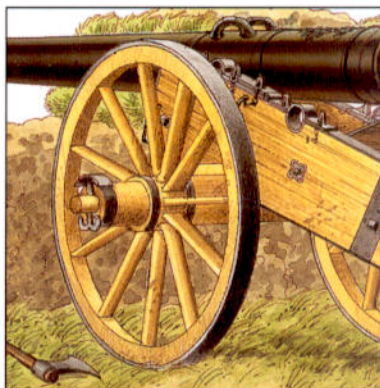

Unrivalled detail

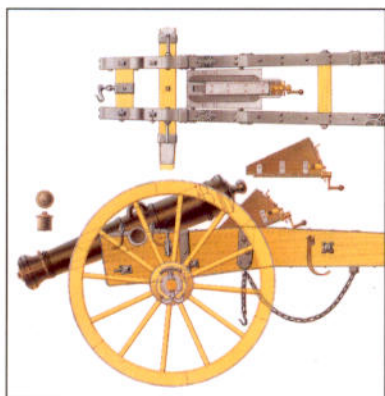

Cutaway artwork



Illustrations

Austrian Napoleonic Artillery 1792–1815

The Austrian artillery of the Revolutionary and Napoleonic Wars was a creation of the renowned Lichtenstein system of the early 1750s. This weight system produced a series of weapons of 3-, 6- and 12-pdr. calibre along with 7- and 10-pdr. howitzers. In the 1780s they were joined by Cavalry artillery guns with their *Wurst* seats. In 1811 Austria also began the establishment of rocket troops based upon the British invention, whilst their heavy and siege pieces remained the 12-, 18- and 24-pdrs throughout the period. This book describes the system as well as its operational use during the Napoleonic Wars.

OSPREY
PUBLISHING

www.ospreypublishing.com

ISBN 1-84176-499-X



9 781841 764993

H/41a
2003