

New Vanguard

OSPREY
PUBLISHING

British Artillery

1914–19

Heavy Artillery

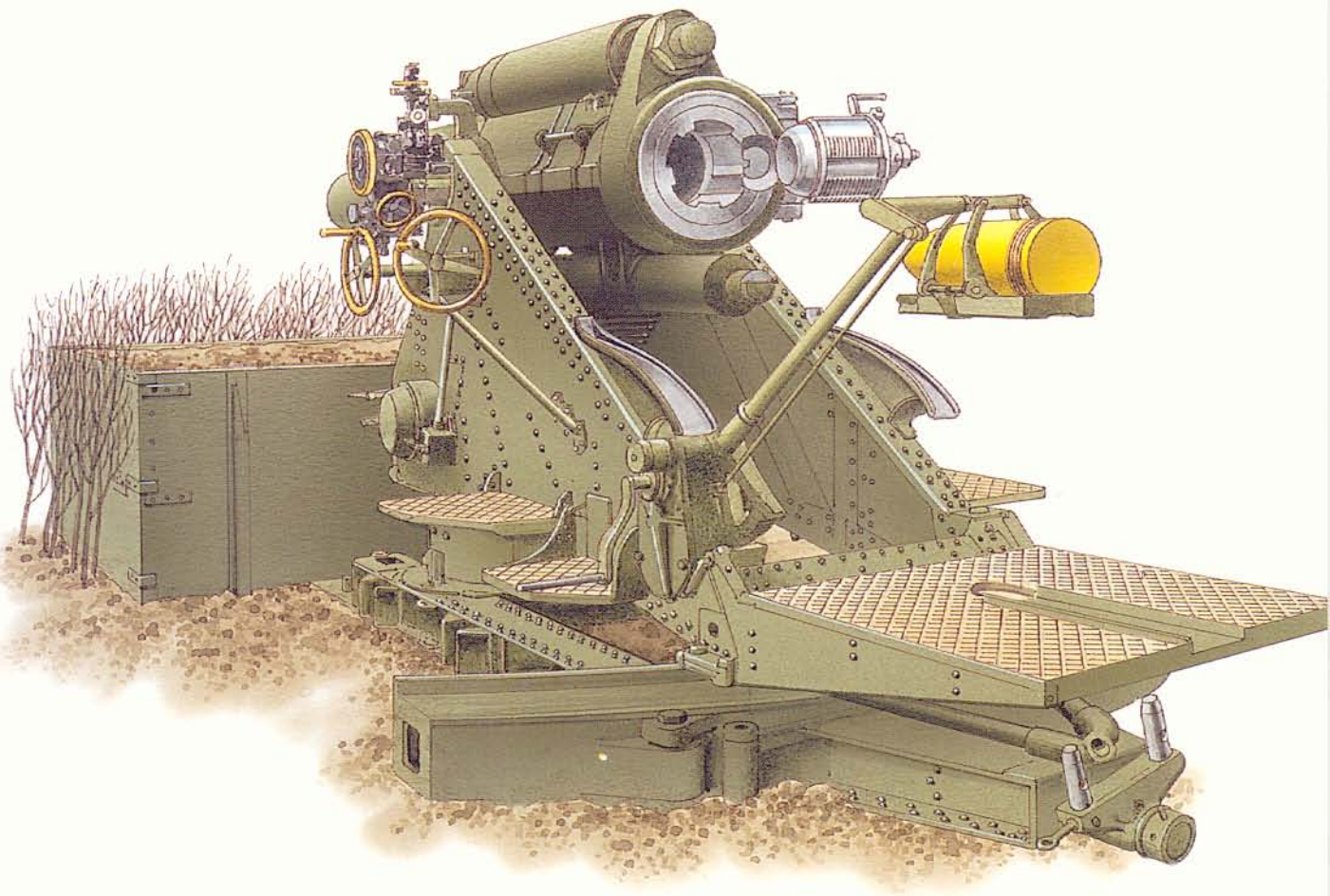

Dale Clarke • Illustrated by Brian Delf



DALE CLARKE has just completed a War in History MA at the Institute for the Study of War and Society at De Montfort University and is about to start a PhD on early modern English fortifications. He also works as a TA staff officer on attachment to the Directorate of Corporate Communications (Army) at the MOD. Previously he has worked as an armourer and technical advisor for film and television with credits including *Captain Corelli's Mandolin*. Dale lives in Kent.

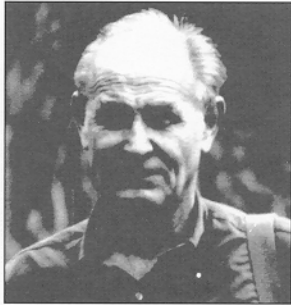

BRIAN DELF began his career working in a London art studio producing artwork for advertising and commercial publications. Since 1972, he has worked as a freelance illustrator on a variety of subjects including natural history, architecture and technical cutaways. Some of his recently illustrated books have been published in over thirty countries. Brian lives and works in Oxfordshire.

CONTENTS

INTRODUCTION	3
<ul style="list-style-type: none">• Royal Garrison Artillery – the Dismounted Branch• Heavy artillery and siege artillery• The Siege Brigade 1902–1914• Training• The Reserves and the Territorial Force• Wartime expansion	
MODERNISATION	7
<ul style="list-style-type: none">• Mechanisation• Ordnance• Logistics• Survey	
ORGANISATION	12
<ul style="list-style-type: none">• A Siege battery in action	
THE GUNS	18
<ul style="list-style-type: none">• BL 6-in. 30cwt siege howitzer• BL 9.45-in. Mk. I siege howitzer• QF 4.7-in. field gun• BL 6-in. Mk. VII gun• BLC 6-in. siege gun• BL 60-pdr Mk. I gun• BL 9.2-in. Mk. I and II siege howitzers• BL 8-in. Mk. I–V howitzers• BL 15-in. siege howitzer• BL 9.2-in. gun on railway mounting• BL 6-in. howitzer of 26cwt• BL 12-in. Mk. IX gun on railway mounting• BL 8-in. Mk. VI, VII and VIII howitzers• BL 12-in. Mk. I, III and V howitzers on railway mounting• BL 12-in. Mk. II and IV siege howitzers• BL 6-in. 35 calibre gun Mk. XIX• BL 14-in. gun on railway mounting• BL 60-pdr Mk. II field gun• BL 18-in. howitzer	
MISCELLANEOUS WEAPONS	42
<ul style="list-style-type: none">• German Field Guns• Mortars	
COLOUR SCHEMES	43
BIBLIOGRAPHY	44
COLOUR PLATE COMMENTARY	45
INDEX	48

New Vanguard • 105

OSPREY
PUBLISHING

British Artillery

1914–19

Heavy Artillery

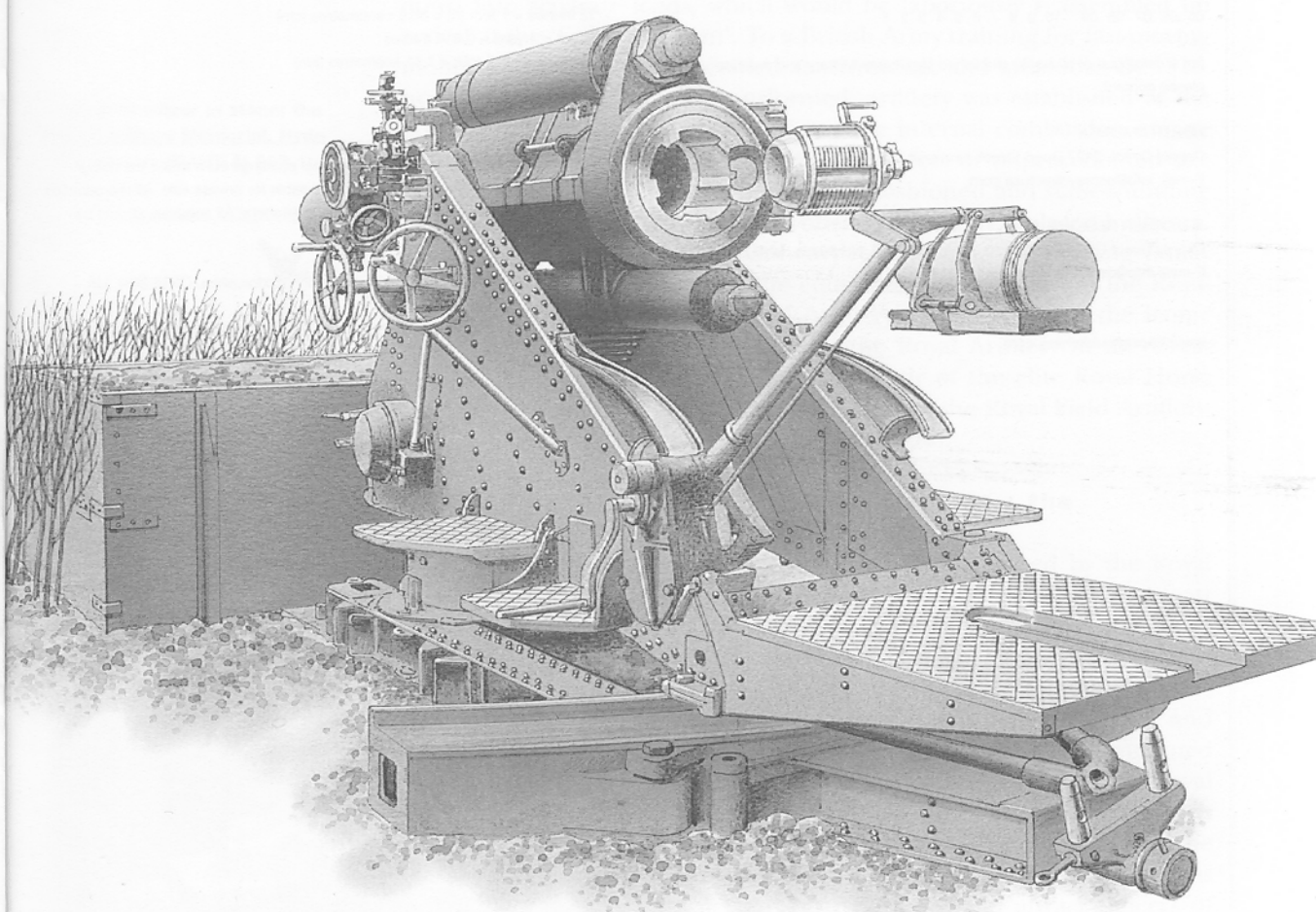

Dale Clarke • Illustrated by Brian Delf

BRITISH ARTILLERY 1914-19: HEAVY ARTILLERY

INTRODUCTION

To the British artilleryman of 1914, 'heavy artillery' described the 4.7-in. and 60-pdr guns attached to the Field Army. Weighing several tons and drawn by teams of eight carthorses, they could only move at a walking pace, just sufficient to keep up with the Field Army in the era before mechanisation. Anything heavier came into the category of 'siege artillery'. Siege artillery was generally moved in pieces, broken down into separate loads, which would be laboriously reassembled on arrival at the 'firing platform'. To a British Army training for fast-moving mobile war, siege artillery seemed anachronistic and inflexible. By 1918, however, the situation was transformed: artillery was established as the dominant force on the battlefield, and the internal combustion engine had given mobility to heavy guns and howitzers of unprecedented size and range. The old-fashioned and static-sounding label 'siege artillery' was largely replaced by 'heavy' and 'super-heavy'. And when the fighting finally stopped, the equipment selected to top the Royal Regiment of Artillery's war memorial, the iconic artillery piece of the Royal Artillery in the Great War, was not the 13-pdr of the elite Royal Horse Artillery, or the 18-pdr of the Royal Field Artillery, but a 9.2-in. siege howitzer.

A siege howitzer in stone: the Royal Artillery Memorial, Hyde Park Corner. (RAHT AL899.1)



Royal Garrison Artillery - the Dismounted Branch

Britain's siege artillery was manned by the Royal Garrison Artillery, which also provided heavy, coast and mountain artillery. In June 1899, the Royal Artillery had been divided, by Royal Warrant, into two separate corps: the 'Mounted Branch', comprising the Royal Horse Artillery (RHA) and Royal Field Artillery (RFA), and the 'Dismounted Branch', comprising the various elements of Royal Garrison Artillery (RGA). This division, which lasted until 1924, was intended to ensure that the technically demanding but rather unglamorous Royal Garrison Artillery would attract officers of suitable quality and offer them appropriate opportunities for promotion. Transfers from one branch to the other were not encouraged, but within the Dismounted Branch it was possible to experience expeditionary warfare with the

mountain batteries or field artillery work with the heavy batteries, and to move from siege to coast defence and back. This breadth of experience was to serve the RGA well during World War I, when it drew on personnel from coast defence to provide the technical expertise in the many new siege batteries formed as the Royal Artillery rapidly expanded.

Heavy artillery and siege artillery

An RGA siege train had been deployed to South Africa in the latter stages of the Boer War (1899–1901) without much success. It was difficult to reconcile slow and deliberate set-piece siege warfare with the doctrine of fast, highly mobile war adopted by the British Army during and after the Boer War. Subsequently efforts were made to increase the mobility of the siege artillery by dispensing with their static siege mountings and to increase their effectiveness against troops in the open by developing shrapnel ammunition. Known as ‘the Field Army Trend’, this move to make the siege artillery more mobile coincided with the establishment of RGA heavy (or ‘heavy field’) batteries, equipped with quick-firing (QF) 4.7-in. guns on field carriages. A naval and coast defence gun, the 4.7-in. had been successfully taken ashore by the Royal Navy to reinforce British field artillery, which was outranged by Boer guns. The ‘Four-Point-Sevens’ greatly extended the range and hitting power of the Field Army artillery, and in 1903 a heavy brigade was formed from three converted siege companies, re-equipped with 4.7-in. guns. A second heavy brigade was formed in 1904 and the 4.7-in. guns were replaced in Regular Army service by new breech-loading (BL) 60-pdr guns from 1905 (see *Field Army Artillery* in this series). Initially, heavy batteries were expected to retain the ability to operate as siege artillery – they were to practise as heavy field artillery in the summer and as light siege artillery during the winter, and to exchange places with siege companies every three years. This was likely to be detrimental to their performance in both roles and, as the benefits of having mobile long-range guns to support the Field Army were quite apparent, the heavy batteries’ siege artillery role was soon abandoned.

Heavy artillery: horse-drawn BL 60-pdr Mk. I guns of 16th Brigade, RGA, march past HRH the Duke of Connaught and General Horn, Mont St Eloi, 1 June 1918. (IWM Q8995)



There was, though, a revival of interest in siege warfare following the ten-month siege of Port Arthur by Japanese forces during the Russo-Japanese War (1904–5). In 1907 the British Army held a 'staff tour' to examine a hypothetical attack on the obsolete but impressive forts defending the naval base at Chatham. This was followed by manoeuvres involving a brigade of infantry, four companies of garrison artillery (three coast, one siege) and fortress engineers with searchlight and balloon detachments. The exercises drew attention to some important points, including the relationship between siege and field artillery, the use of observation posts, command and control, and the provision of ammunition and stores. Having been omitted entirely from the British Army's manual *Combined Training 1905*, siege operations earned a chapter in *Field Service Regulations*, which replaced it in 1909.

The Siege Brigade 1902–1914

The Siege Brigade was re-formed in 1902 and went through various reorganisations up to 1914, including the requirement to detach companies to provide the new heavy batteries. However, the basic structure remained the same – three companies, which would each expand into two batteries on mobilisation, forming two brigades: a medium brigade of four batteries of four 6-in. howitzers and a heavy brigade of two batteries of four 8.5-in. howitzers. They would be joined by three batteries of four 6-in. coast defence guns, manned by personnel from the coast artillery. Of these equipments, only the 6-in. 30cwt howitzers were actually in service. The 8.5-in. howitzers never got beyond the design stage, so the third siege company, intended to form the heavy siege brigade on mobilisation, was issued four Skoda M1898 9.45-in. (24cm) howitzers, purchased secretly during the Boer War and subsequently considered unsuitable for anything other than training. Development of an effective mobile mounting for the 6-in. coast defence gun continued up to the outbreak of war in 1914.

In addition to the UK-based siege companies, the siege artillery in India consisted of two companies equipped with the 6-in. 25cwt howitzer, which was similar in design and performance to the 6-in. 30cwt.

BL 6-in. 26cwt howitzer at the Officer Training Establishment, Trowbridge, 1916. The wheels have been fitted with 'girdles', and the 'side arms' (drag ropes, handspikes etc.) laid out for inspection. (RAHT AL1164.1)



Training

During the final years of the 19th century, British siege artillery had elevated bombardment to an exact science. This depended on the ability to observe the target and fall of shot with complete clarity, and was practised on the flat and formal ranges at Lydd on the south coast of England. In 1903 new ranges were established to train heavy batteries, on moorland at Rhayader in Wales. From 1905 the siege companies started to use the ranges, brigade practice taking place at Rhayader and Lydd in alternate years. Here it was easy to lose a ranging shot into dead ground, or have it swallowed-up in a bog. Gun positions were dug and observation posts established in rugged 'field' conditions – leading to a transformation in training as batteries adopted quick and flexible field artillery methods, such as the 'clock face' for indicating targets and the 'aiming point' for obtaining the line of fire. Much effort was dedicated to producing better, simpler and lighter fire direction equipment, rangefinders, telescopes, binoculars and all the other miscellaneous items needed to bring effective fire to bear. In 1913 siege artillery methods of fire and orders for fighting the battery were brought into conformity with those of the field artillery.

The Reserves and the Territorial Force

In the absence of conscription or compulsory national service, the Siege Brigade was able to expand to its full wartime establishment through the recall of Reserves – men who had served as Regular soldiers with the RGA and remained liable to be called up from their civilian occupations. There were, in addition, the part-time soldiers of the Volunteer batteries. In February 1900 Parliament approved the provision of 4.7-in. guns for Volunteer heavy batteries, and in 1907 the Volunteer and Yeomanry regiments were reorganised and reequipped, establishing a new army of part-time soldiers, to be known as the Territorial Force (TF). TF artillery included 14 heavy batteries (one for each TF division), a further six heavy batteries and 96 (later reduced to 76) garrison companies for coast defence.

Wartime expansion

In 1914 the three companies of the Siege Brigade expanded, as planned, into six siege batteries. This proved to be hopelessly inadequate, and by the Somme offensive of July 1916 over 100 siege batteries had been



Baby, a camouflaged BL 6-in. gun, taken from coastal defence, on a travelling carriage Mk. I, 1914–15. (RAHT AL190.3.26)

formed, largely from the 'New Army' – the 2.6 million men who had rallied to Secretary of State for War Lord Kitchener's call for volunteers, with a leavening of experienced gunners from the coast defences. Between 1914 and 1918, Britain's heavy and siege artillery expanded from 32 heavy batteries and six siege batteries to 117 heavy batteries and 401 siege batteries. Batteries were also provided from Commonwealth and Empire troops and the Royal Marine Artillery (RMA).

MODERNISATION

In 1915, with their advance halted, the Germans established a defensive line, giving ground where necessary to ensure that they always occupied the ground of tactical advantage. The Allies were faced with the prospect of either accepting a new German frontier or attacking – everywhere on ground of the Germans' choosing. 'Trench warfare' was, in many respects, siege warfare, with the Allies attempting to force a breach through an increasingly sophisticated and formidable line of fortifications. Unfortunately, even in the resurgence of interest that followed the siege of Port Arthur, British military planners had not anticipated a siege action any larger than the attack or defence of a fortified port or fortress town. They had certainly never envisaged attacking a fortress frontier stretching from Switzerland to the Channel.

RGA siege batteries went to war in 1914 with the same 6-in. 30cwt siege howitzers they had taken to South Africa at the turn of the century. The lack of development in the intervening years had been due, to a great extent, to the difficulty of designing a piece of artillery of worthwhile size that could be moved using horses. A team of heavy horses became impractical if more than eight were used, which imposed an absolute limit on the weight of any mobile artillery equipment. Immediately after the Boer War, siege companies each had the use of a heavy steam traction engine or 'Steam Sapper', but these were withdrawn and not replaced. Although consideration had been given to mechanising the heavy

batteries, the normal means of moving heavy guns and siege howitzers remained, until 1915, teams of heavy horses. As part of the 'Dismounted Branch', the Edwardian heavy batteries were each established for just 12 horses, and were only able to train by pooling their resources. The allocation was increased to 20 in 1911 and was supposed to increase further, to 33 per battery, in 1914/15 but the increase was cut out of the Army budget. In the end additional horses were found at the expense of the field artillery – indicating the importance the Royal Artillery was attaching to heavy artillery by 1914.

Siege artillery trained alongside the Field Army for the first time in the great manoeuvres of 1912. Two siege companies were deployed and the howitzers were drawn, as they always had been, by hired teams of heavy draught horses, but the prospect of the modern British Army's siege

BL 6-in. 30cwt howitzer of 6th Siege Battery, RGA, 1914–15. The ammunition wagon has been placed alongside the howitzer, which is mounted on its siege platform. The detachment is posing with handspikes. The overhead camouflage screen is typical of British World War I siege artillery positions. (RAHT AL190.3.27)



artillery progressing across East Anglia led by contractors' stablemen was too much to be contemplated. The Siege Brigade turned down the offer of drivers from the Army Service Corps and, with the help of other mounted units, began to train its own cadre of drivers.

Mechanisation

The first four siege brigades formed during World War I were horsed but, as the siege artillery rapidly expanded, it was quite impossible to find the huge number of draught horses needed to move the big guns and howitzers. British siege howitzers and heavy guns had been moved around by steam traction engines since the 1850s and fitted with 'engine draught connectors' from the earliest years of the 20th century. Indeed, steam traction engines were extremely useful for moving very heavy guns on roads and firm ground, but their slow starting time from cold and their distinctive plumes of smoke and steam made them quite unsuitable for bringing guns into action. Trials with an 8-ton, 70-horsepower, Hornsby chain-track tractor in 1910 showed it to be slower on the march than horses, and no better cross-country. With no interest from the Royal Artillery, or the UK agricultural market, the Hornsby chain-track tractor project lapsed. In the United States, however, the Holt Company developed very large chain-track 'Caterpillar' tractors for agricultural use. As no domestic model was available following the abandonment of the Hornsby, the War Office was forced to buy American Holts once war had broken out. The importance of these 'Caterpillar' tractors was not their ability to cross difficult terrain (less of a requirement for siege artillery), or their speed (which was little more than a walking pace), but their immense power. During World War I the War Office purchased over a thousand 75-horsepower Holts, transforming the mobility and firepower of the siege artillery and making it possible, indeed quite straightforward, to deploy 6-in. guns and 8 and 12-in. howitzers on field or travelling carriages.

As early as 1908 a gunner had suggested mounting an artillery piece directly onto a chain-track tractor, but it was another nine years before a tracked gun carrier arrived on the battlefield. The Gun Carrier Mk. I was designed to transport heavy artillery across friendly trenches, through no-man's land and over enemy trenches, to enable it to support a successful breakthrough. The carrier was an open-fronted, open-topped tracked vehicle, based on components of the Mk. I tank, and built to carry a 6-in. 26cwt howitzer or 60-pdr gun. The gun or howitzer was reversed onto the carrier, its weight was taken on a cradle mounted on a ramp and, the wheels removed, it was then winched back along the ramp into the machine and the wheels stowed on the sides. The 6-in. howitzer could be fired on board, but the 60-pdr could not, the barrel being in the travelling position for transport. Fifty gun carriers were ordered in March 1917, of which 48 were completed and in service on the Western Front a few months later. Although the prototype of subsequent tracked self-propelled guns, the gun

Gun carrier *Dublin* transporting a BL 6-in. 26cwt howitzer, its ammunition and detachment. Irlles, the Somme, 25 August 1918. (IWM Q61069)



carrier Mk. I was not particularly successful, owing to mechanical unreliability and lack of opportunity. The machines were regarded as being more useful as ammunition or 'supply' carriers, capable of moving 10 tons of 6-in. shells in a single trip.

A far more successful vehicle was the 'FWD', a 3-ton all-wheel-drive lorry built by the Four Wheel Drive Auto Company of Wisconsin. Purchased for the British Army from 1915, these proved to be ideal tractors for 6-in. howitzers. The FWD could tow the gun and limber and could carry ammunition and the detachment as well, enabling the siege artillery to achieve field artillery levels of mobility.

Ordnance

The 6-in. 30cwt howitzer was a versatile and well-thought-out piece of equipment that, in 1896, superseded the various rifled muzzle loading (RML) guns and howitzers that formed the Victorian siege train, greatly simplifying logistics and training. But it was quickly apparent that siege artillery armed only with a 6-in. howitzer was not powerful enough. In 1899, faced with the prospect of attacking powerfully armed modern forts defending Pretoria, the Director General of Ordnance opted for an 'off-the-shelf' solution and purchased four M1898 24cm siege howitzers from the Austro-Hungarian firm of Skoda (renowned as leading manufacturers of large-calibre siege mortars and howitzers). Arriving in mid-1900, the 9.45-in. howitzers, as they were known in British service, played no useful role during the Boer War, or later when dispatched to China, and, because of inaccuracy and lack of range, were soon relegated to training. The 9.45-in. howitzer had a number of interesting features, not all of which were desirable, and there was little to learn from the ordnance itself, but the siege mounting was another matter. The 9.45-in. did not travel on a regular field carriage but as two loads, each slung from four wheels. Although less flexible than a conventional field carriage (from which a piece could be fired if necessary) this system made it feasible to move a large-calibre gun or howitzer and its mounting as separate loads behind teams of horses, or linked together *en train* with mechanical draught, and assemble it quickly when it reached its destination.

BELOW AND OVERLEAF
BL 9.45-in. howitzer dismantled for transport. The barrel and cradle have been removed to form one 'wagon', the bed and carriage the other. The inverted L-shaped item on the carriage is the loading tray. (Reproduced courtesy of RAHT)

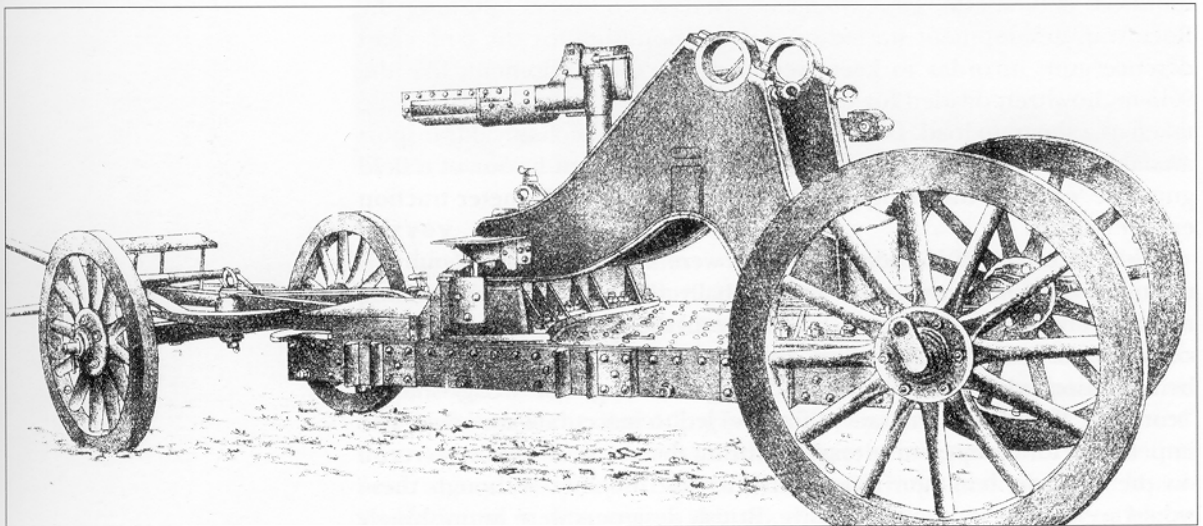

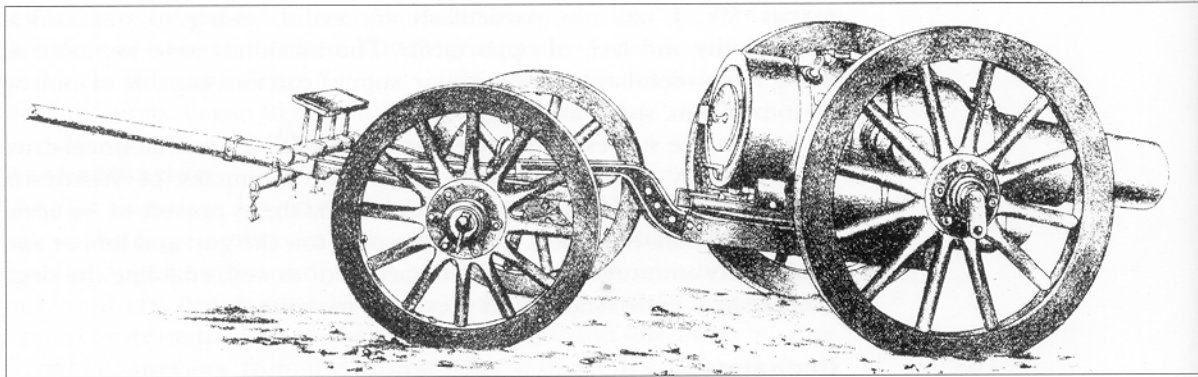

Since the 1890s, work on a British heavy siege howitzer of around 8-in. calibre had continued in a desultory fashion. This had eventually been abandoned and it was suggested that, if necessary, surplus 'high angle' RML 10-in. coast defence guns could be placed on siege platforms made from quick-drying concrete. As this concept required no further investment, it met with widespread support – outside of siege artillery circles. In 1912, however, sense prevailed, and 'conditions' (i.e. specifications) for a new 'heavy mobile howitzer' were issued to British arms manufacturers. It was to be of 9-in. to 9.2-in. calibre, with a range of 10,000 yards, and the siege mount was to be of similar type to that of the 9.45-in. howitzer. The prototype (known as *Mother*) of the new equipment – the BL 9.2-in. siege howitzer – was delivered for trials in 1913. It was approved in July 1914 and was in France with the British Expeditionary Force in October 1914. The howitzer was a conventional piece of ordnance, the significant innovations being the design of the siege mount and the hydro-pneumatic recoil system, which used air and liquid separated by a 'floating piston' to absorb recoil and return the barrel to battery. This proved entirely successful, and was eventually adopted for all British artillery. A Mk. II howitzer, with greater range, entered service in 1915 and similar equipments were built in 12-in. and 15-in. calibre.

Guns had ceased to be part of the siege train with the adoption of the 6-in. 30cwt howitzer and it was planned that, if heavy siege guns were required, 6-in. coastal guns would be used. In the years following the Boer War, development started on a siege mounting for the 6-in. coast defence gun. In order to keep weight down, the equipment, like the 9.45-in. howitzer, divided for transport, with the barrel and cradle being taken as a separate load. During World War I, with mechanical transport available, the 6-in. gun siege mount was abandoned in favour of a field gun-style 'carriage travelling', a robust box trail on 6ft-diameter traction engine wheels.

From February 1915 older 6-in. guns were shortened, bored out and mounted on field carriages in order finally to meet the long-standing requirement for 8-in. howitzers. These, like all the early heavy artillery field carriages, lacked effective buffers and recuperators, much of the recoil being absorbed by the carriage rolling back against wedge-shaped 'scotches'. This slowed the rate of fire and led to inaccurate shooting. The imperatives for equipments designed during the war were to absorb recoil on the carriage, lengthen range and increase mobility. Although these would seem to be mutually exclusive, British designers were astonishingly

successful in creating what were, in effect, very large field guns and howitzers, the 6-in. 26cwt howitzer (1915), the BL 6-in. field gun Mk. XIX (1916) and the 8-in. howitzer Mk. VII (1916) all being greatly superior to their predecessors. The need for still more powerful artillery on the Western Front led to the construction of railway mountings for coast defence guns. The combination of a static front line and a good existing rail network – with the potential to extend further, by adding special spurs for the guns – made it possible to deploy truly massive – ‘super-heavy’ – artillery: guns of 9.2-in., 12-in. and 14-in. calibre, as well as 12-in. and 18-in. howitzers.

Logistics

In 1915 demand for ammunition exceeded supply – the ‘Shell Scandal’ – which resulted in a complete restructuring of Britain’s armament production. With this achieved, the highly developed railway systems of Britain, France and Belgium enabled shells manufactured in Britain’s industrial Midlands to be transported directly from the factory siding to an ammunition dump in France or Belgium. From there they were moved forward on 60cm gauge light railways before being transferred to tramways (similar, but much more lightly laid) that frequently ran almost to the trails of the guns. Without this flow of ammunition from factory to gun position the siege artillery simply could not have shaped the battlefield of the Western Front in the way it did – almost 5,000,000 tons of artillery ammunition were delivered to the Western Front during the course of the war.

Stack of 6-in. howitzer ammunition abandoned at a battery position in the Ypres salient – each shell weighed 100lbs. Note the ‘Decauville’ 60cm gauge pre-fabricated track (background), which would have brought the ammunition right onto the gun position. (RAHT AL692.12)



Survey

On the Western Front it was unusual for siege batteries to be able to observe, from the gun line, the targets they were engaging. Firing was usually ‘indirect’ and at long range. This made it vitally important to know where *exactly* the guns and their targets were located. The ‘surveying-in’ of gun positions and the production of maps were the responsibility of the Royal Engineers. Topographical support increased from two officers, two clerks and a printing company in 1914 to five field survey battalions in 1918. The Royal Engineers also developed sophisticated techniques to identify the location of enemy batteries by



Interior of a primitive OP in a barn at Precepteur, Foucaucourt, October 1915. Sandbags and hay bales have been arranged to give protection. (RAHT AL445.56)

flash-spotting and sound-ranging. Flash-spotting by trained RE/RA observers was being used by the British 3rd Army in the autumn of 1915. Each post took a bearing on the flash of an enemy battery firing and, by triangulating from several posts, could pinpoint the enemy battery on the map and fire on it. Sound-ranging depended on a line (later an arc) of microphones recording the sound of a gun firing and displaying the point at which the sound was recorded by each microphone on film or a paper roll. This required the most sophisticated experimental science available during World War I and was accordingly viewed with deep mistrust by the Royal Artillery. However, a practical and highly effective equipment was developed – as demonstrated by a German Group Order, dated 23 June 1917, stating: ‘In consequence of the excellent sound-ranging of the English, I forbid any battery to fire alone when the whole sector is quiet, especially in east wind. Should there be occasion to fire the adjoining battery must always be called on ... to fire a few rounds.’¹ Apart from demonstrating their effectiveness, the instruction delighted British sound-rangers who knew that their equipment could easily identify and locate more than one battery at a time.

ORGANISATION

Siege Artillery batteries were organised as best suited the very large and heavy equipments they were using: thus a battery might serve four 6-in. or 8-in. howitzers or two 12-in. or 14-in. railway guns. 135th Siege Battery, RGA, for example, was a typical New Army battery, equipped with four 8-in. howitzers. Formed in May 1916, largely from new recruits serving with the 12th and 47th Tynemouth RGA companies, the battery embarked for France in August 1916. 135th was organised into a headquarters and two *sections*: ‘Right Section’ comprised A and B *subsections*, ‘Left Section’ C and D ‘subs’. Each sub operated one 8-in. howitzer Mk. V. An Army Service Corps column, composed of a Daimler car, four Caterpillar tractors, four or five motorcycles and sidecars and some 30 Commer lorries, supported and moved the battery.

The Honourable Artillery Company (309th) Siege Battery was unusual in that it was a new Territorial Force siege battery, formed in 1916 and

arriving in France in April 1917 (see Plate C). However, its organisation was entirely conventional, consisting of Headquarters, 'Right Section' (A and B subsections), and 'Left Section' (C and D subs), with one 6-in. 25cwt howitzer per sub. When 6-in. howitzer batteries were increased to six howitzers in 1918, the additional two howitzers were added as 'Centre Section', taking over the C and D sub designations, the old C and D subs becoming E and F. Each howitzer and limber was towed by a FWD. The battery Army Service Corps column consisted of a further 13 conventional lorries, a car and motorcycles.

A siege battery was commanded by a major, the Battery Commander or BC, often referred to as simply 'The Major'. It was the BC's task to 'fight the battery'. In 1914 siege artillery direction of fire was based on the use of two observation posts. These were established on a 'baseline' of known length (about one tenth of the distance to the target). Each OP ('O Pip' in the phonetic alphabet of the period) used an observation of fire instrument (a graticuled telescope, rotating on a plate graduated in degrees) to measure the bearing to the target, and the combination of these angles and the known distance between the OPs allowed a triangle to be drawn, pinpointing the target. In traditional siege work, one OP might be on the gun line, but on the Western Front this was unlikely to be the case and further calculation had to be done to establish the relationship between the target and the battery. This could all be done very quickly by a good non-commissioned officer or soldier using a slide rule and field plotter – a simple mechanical device for solving triangles. The OPs were in telephone communication with the BC back at the battery, and it was his job to direct fire onto the target and adjust the fall of shot according to bearings received from the OPs. Known as the 'Exact Method', this type of direction was highly accurate and, with a well-trained team, surprisingly fast. The 'Field Army Trend' had also seen the siege artillery begin to practise heavy artillery-style fire direction with a single OP. The BC would go forward to the OP and give his orders to the battery from there. Once the target had been located on the map, fire would be adjusted by 'bracketing' – dropping a round, making a bold adjustment to bring the next round the other side of the target, then halving each subsequent adjustment until the round was on target. More rough-and-ready than the 'Exact Method', this required less preparation and specialist equipment.

The BC's party comprised three trained soldiers. The 'BC's Assistant' ('BC's Ack') was a non-commissioned officer who recorded the adjustment of fire on the ranging sheet and made calculations to work out changes to elevation and deflection. The 'Plotter' calculated and reported the positions of each shell burst. The third man was used 'as necessary'. OPs were in contact with the battery, and the battery with brigade HQ, by telephone, via the battery exchange (BX), which was run by the signals officer (a lieutenant) and signals sergeant. A captain deputised for

Plotter and case on display at Firepower, the museum of the Royal Artillery, Royal Arsenal, Woolwich, London. (Author's photograph, reproduced courtesy of RAHT)

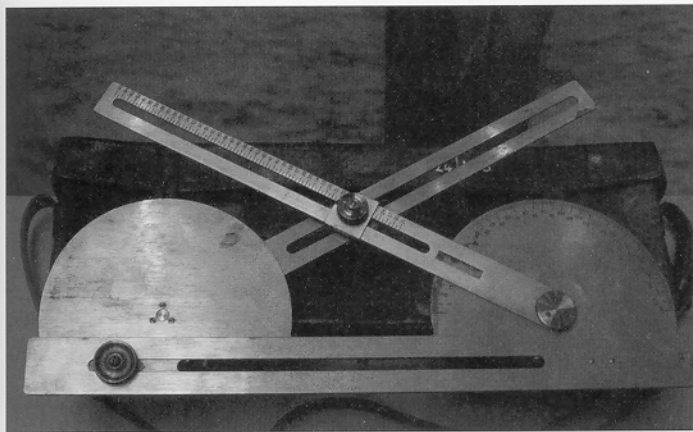

the BC and organised the administration of the battery, assisted by the Battery Sergeant Major (BSM), Battery Quartermaster Sergeant (BQMS), clerks and HQ staff. The gun position was run by the senior subaltern, the 'Battery Officer'. In a battery of 6-in. howitzers, each section consisted of about 18 men and was commanded by a lieutenant (the section commander or XC). The section included a sergeant, who commanded one subsection, with a bombardier (lance corporal) to deputise for him. A corporal, also supported by a bombardier, commanded the other subsection. Total manpower, including cooks, artificers, observers and limber gunners was 137 of all ranks (180 in a six-gun battery).

Heavy batteries, as part of the Field Army, were under divisional command, while siege batteries were a corps-level asset. Siege batteries were formed into confusingly named Heavy Artillery Groups, typically of five batteries each. These regiment-sized organisations were commanded by lieutenant colonels. As increasingly huge amounts of artillery were gathered together, further confusion was added by the creation of 'mixed' groups such as 77th Heavy Artillery Group, which comprised two heavy batteries and four siege batteries, and 'double groups' – two HAGs under one lieutenant colonel. In 1918 Heavy Artillery Groups became Artillery Brigades, Royal Garrison Artillery.

Heavy Artillery Groups were organised, and reorganised, as best suited the situation in their sector, and it is beyond the scope of this book to describe them. It is instructive, however, to examine one – the 25th Heavy Artillery Group, Royal Garrison Artillery, part of VIII Corps Heavy Artillery, British 2nd Army, as it stood in April 1918 during the German 'Michael' offensive (the *Kaiserschlacht*) – if only to demonstrate the extraordinary diversity of 'super-heavy' that could be gathered in one group. The group order of battle is set out below. In August 1918 its designation was changed to 25th Army Brigade, RGA; it was demobilised in June 1919.

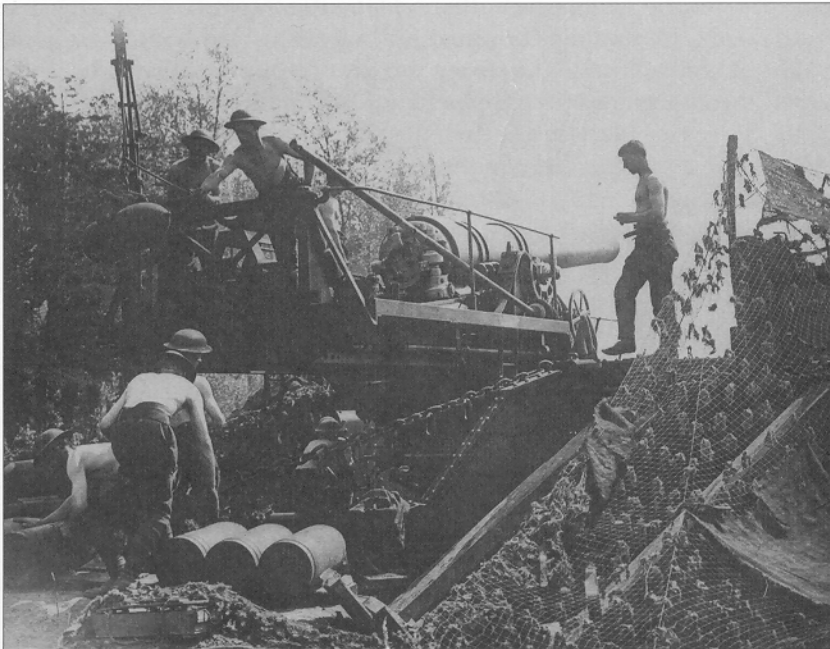

Loading a BL 12-in. railway howitzer Mk. V of 444th Siege Battery, RGA, 1918. (RAHT AL978.2)

25th Heavy Artillery Group RGA, Ypres, April 1918

April 18:

Gun 12, Royal Marine Artillery (15-in. howitzer. Allocated to IX Corps, 27 April)

18th Siege Battery RGA (2 x 12-in. railway howitzers)

85th Siege Battery RGA (2 x 12-in. Mk. IV howitzers. Allocated to IX Corps, 28 April)

103rd Siege Battery RGA (2 x 12-in. Mk. I railway howitzers)

434th Siege Battery RGA (2 x 6-in. Mk. VII guns)

Right Section 92nd Siege Battery RGA (1 x 9.2-in. Mk. IVE railway gun. Allocated to 72nd Army Brigade, 16 April)

Left Section 363rd Siege Battery RGA (Allocated to XXII Corps, 15 April. 1 x 9.2-in. Mk. X railway gun)

The guns were withdrawn to prevent their capture by the advancing Germans, and the brigade headquarters regrouped at Wormhoudt, on **16 April**, taking responsibility for the 6-in., 8-in., 9.2-in., 12-in. and 15-in. batteries in the vicinity. On **10 May** the Group transferred to XV Corps and established a headquarters in the region of Hazebrouck.

On **24 May 1918**, two further batteries joined the group:

On **28 May** further heavy howitzers were attached to make the most of railway infrastructure in the group's area:

31 May:

4 June:

82nd Siege Battery RGA (1 x 12-in. Mk. I railway howitzer, the other under repair until 15 May)

359th Siege Battery RGA (1 x 12-in. Mk. III howitzer, the other having blown up)

366th Siege Battery RGA (2 x 9.2-in. Mk. XIII guns)

582nd Siege Battery RGA (two thirds of personnel Royal Marines, 2 x 6-in. Mk. XIX guns)

7th Siege Battery RGA (2 x 6-in. Mk. VII guns)

187th Siege Battery RGA (2 x 6-in. Mk. XIX guns)

89th Siege Battery RGA (2 x 12-in. Mk. I howitzers)

Left section 543rd Siege Battery, RGA (12-in. Mk. IX gun, ex HMS *Cornwallis*)

63rd Siege Battery RGA (2 x 12-in. Mk. I howitzers)

A BL 12-in. railway howitzer Mk. I, near Elverdinghe. The equipment is painted in a three-colour, black-outline dazzle camouflage. (RAHT AL1163.23)



When the group totalled seven 12-in. howitzers, one 12-in. gun, two 9.2-in. guns and eight 6-in. guns, the total weight of a single one-round salvo from all guns was 3¼ tons.

A Siege battery in action

Siege batteries were usually located some thousands of yards behind the front line. Once established, the guns could not be easily or quickly moved and, once located by the enemy, they were subject to savage counter-bombardment. Individual guns were therefore carefully camouflaged from aerial observation. The guns of the Royal Artillery are its 'colours' (the equivalent of regimental flags), and it is unthinkable to abandon them in action. However, Japanese experience in the Russo-Japanese War had demonstrated that while counter-battery fire could quickly decimate gun crews, nothing less than a direct hit could disable a gun. A battery could retain its effectiveness much longer if the crews took cover away from the guns when the position was under bombardment. This pragmatic approach flew in the face of traditional Royal Artillery ethos, but was adopted as a standard procedure – the detachments 'clearing to a flank' under bombardment unless they were themselves firing. Detachments lived and sheltered in dugouts, the effectiveness and elaborateness of which depended on the nature of the ground and the time the battery had spent in that location. OPs also varied in sophistication. As potential observation points were easily identified by the enemy, OPs could be shell-proof concrete structures hidden inside buildings, or underground chambers with submarine-style periscopes that emerged at the lip of a crater or inside an artificial tree.

A battery might find itself firing as part of a barrage, firing by the map (often the case with long-range super-heavies) or taking part in an 'aeroplane shoot'. Aeroplane shoots generally took place early in the morning, and were slow and tedious for the gunners. The aeroplane was in contact with the guns by wireless telegraphy (radio) and the guns with the aeroplane by 9ft letters laid out on the ground.

Examples of aeroplane code:

L: Ready to engage target

H: Your signal is weak

V: Repeat

T2: Go home for two hours

OK: Directly on target

Y: Good close shot

NF: Enemy battery now firing – a priority target

GF: Fleeting opportunity target

A bombardment fired by 135th Siege Battery on 3 May 1917 serves to demonstrate typical routine in an 8-in. howitzer battery: The attack was timed for 0345hrs, just before dawn. The detachments were roused by a sentry at least an hour before zero hour to give them time to prepare their ammunition. This meant removing the rope 'grummets' that protected the shells' copper drive bands, taking a bucket of water from a nearby shell hole to wash mud off the shells (leaving mud on was to invite a 'premature' – the shell exploding in the barrel), removing the plugs fitted in the noses of the shells and fitting fuzes. Meanwhile the limber gunner, responsible for maintaining the howitzer, removed the covers from the muzzle and breech and oiled up the moving parts of 'his

gun'. The battery commander and his 'Ack' wrote out the angles of fire and bombardment programme for each gun on slips of paper, which were delivered to the guns by the battery officer. At zero minus 15 minutes the guns were laid on their initial targets and the order given to 'load'. The officers checked the laying of each gun – a buzz of activity going on all along the line of gun batteries. Then silence fell, broken only by the battery officer calling out the 'Official Time'. At zero minus one minute came the order 'Stand-by for gun fire', then: '30 seconds', '20 seconds', '10 seconds', 'Battery – Fire!'

The battery commenced with rapid fire – half of the 630 rounds fired had been expended by 1000hrs – the rate of fire slowing as the day wore on (each 8-in. shell weighed 200lb, and was propelled by a 9.36lb bagged charge of cordite).

Official gun drill allocated certain tasks to each of the members of a gun detachment. In action on the Western Front, detachments were frequently under strength because of casualties or because men were being withdrawn to the rear for rest.

A BL 6-in. 30cwt howitzer firing in Mesopotamia. (RAHT AC9)

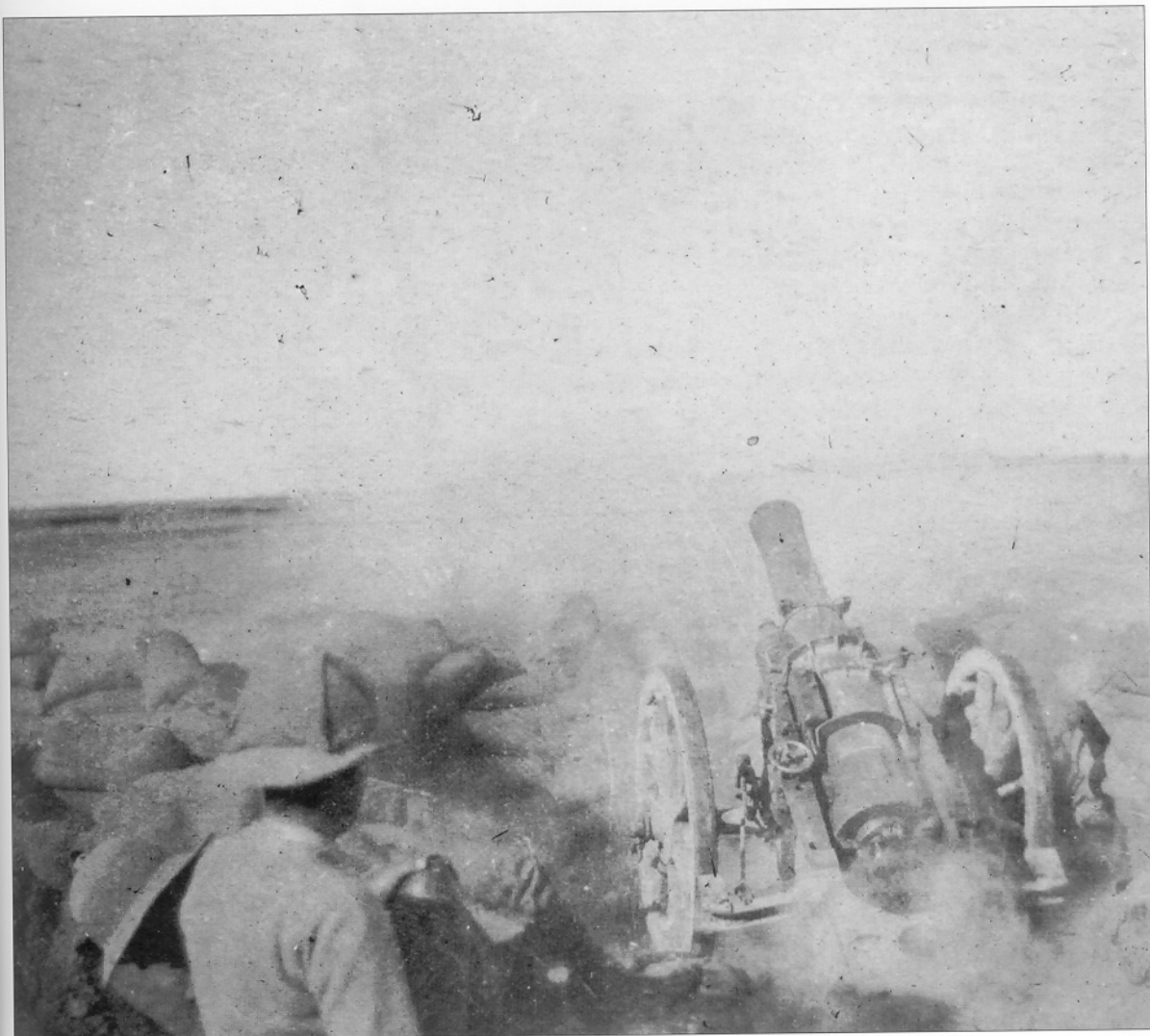

DUTIES OF A 6-in. 26cwt HOWITZER DETACHMENT

Number 1: Commands the 'gun' (howitzer). Selects ground for gun platform. Lays for elevation and passes angle for dial sight and deflection to No. 4. Supervises ramming and gives order to fire. Fits and removes rocking bar sight with No. 4.

Number 2: Opens and closes the breech. Inserts tubes in the vent. Fires the gun. Operates the rapid elevating gear, putting the gun in and out of loading position ($7\frac{1}{2}^{\circ}$ elevation). Applies right brake as soon as the gun laying is complete (unless girdles are fitted – see Plate C3). Attends to the right brake when travelling (horse-drawn batteries). Removes and replaces muzzle and breech covers. Assists No. 3 in lifting and traversing the trail.

Number 3: Rams home the round (with No. 5). Uncaps fuzes. Applies left brake as soon as laying is complete (unless girdles are fitted). Attends to the left brake when travelling (horse-drawn batteries). Assists No. 2 in lifting and traversing the trail.

Number 4: Lays (aims) the gun, with No. 1. Removes and replaces sight cover. Assists No. 1 fitting rocking bar sight. Clamps dial sight, fits clinometer. Directs No. 6 planting night-firing picket and aiming posts.

Number 5: Rams home the round (with No. 3). Assists No. 10 cleaning and fuzing shells.

Number 6: Prepares, fetches and loads cartridges. Plants night-firing picket (with No. 9) and aiming posts. Assists No. 7 clearing the spade when choked.

Number 7 and 9: Assist No. 10 preparing shells. Carry shells to the gun. No. 7 assists No. 6 to clear the spade when choked. No. 9 plants picket with No. 6.

Number 8: (an NCO) Prepares charges (cartridges) and groups by lots. Keeps record of charges.

Number 10: Issues shells, and issues tubes to No. 2. Ensures shells are clean and fuzed.

THE GUNS

All artillerymen referred to their equipments as 'guns', although some were actually howitzers and others mortars. A *gun* is an artillery piece that starts with its barrel near the horizontal and *elevates* the muzzle to achieve greater range. A *howitzer* starts with its barrel at around 45° , or more, and *depresses* its muzzle to achieve greater range. A howitzer also has the option

of a variable charge – made up of separate bags inserted in the cartridge – to further vary the range for any given angle of elevation. Guns were long-barrelled with a high muzzle velocity; howitzers were short-barrelled with a low muzzle velocity. Trench mortars were simple muzzle-loaders, with an unrifled barrel and no recoil mechanism, throwing a large shell or bomb a short distance.

The combination of *ordnance* (the barrel and breech mechanism) and *carriage* is correctly termed an *equipment*. The same ordnance might be mounted on different styles of carriage, and this is reflected in the official nomenclature – *Ordnance BL 6-in. gun Mk. VII on carriage 6-in. gun Mk. I, II or III*, for example. The recoil mechanism – cradle, buffer and recuperator – forms part of the carriage. The cradles of pre-war guns and howitzers were more or less cylindrical, enclosing the barrel and carrying oil buffers and spring recuperators. They allowed only 18in. or so of on-carriage recoil, the majority of the shock of firing being transmitted to the mount or carriage. Later patterns were, typically, rectangular structures beneath the barrel. These contained hydro-pneumatic buffers and recuperators and allowed the barrel to recoil several feet, absorbing much of the recoil energy.

Different types of ordnance firing a similarly sized projectile were differentiated by weight, e.g. the 6-in. howitzer of 30cwt (a 6-in. calibre howitzer, with a barrel and breech assembly weighing 30cwt) and the 6-in. howitzer of 26cwt. Traditionally, the Army's guns were described by the weight of their projectile (60-pounder for example); howitzers and mortars by the diameter of the projectile in inches. However, World War I British siege guns were of naval origin and designated by calibre – hence 6-in. gun, 9.2-in. gun, 12-in. gun and 14-in. gun.

The 'quick fire' (QF) gun had, during the early years of the 20th century, become dominant in light naval, coast and field artillery. British QF guns and howitzers used a brass cartridge case, which contained the propelling charge and primer and which expanded on firing to seal the breech. This, together with on-carriage long-recoil and single acting breeches, resulted in very high rates of fire. With the exception of the QF 4.7-in. gun, British heavy and siege artillery was breech-loading or BL. BL artillery used combustible cloth bags to hold the propelling charge. Breeches were sealed by the action of a steel 'mushroom piece'

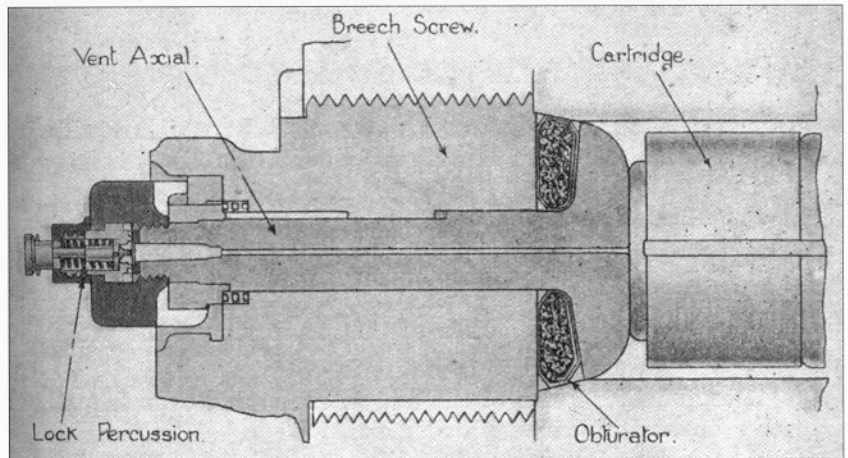

Cutaway of the breech of a BL gun. The 'T' shaped steel 'mushroom piece' was forced back when the gun was fired, squeezing the asbestos ring, the 'obturator', outwards, making a gas-tight seal at the breech. Note the percussion lock (left), which fires a .303-in. blank 'tube' to ignite the pad of blackpowder at the base of the cartridge, which in turn ignites the cordite charge. (Author's collection)

that was pushed back against a fibre ring by the expanding gases in the chamber, sealing the breech – a simple system that proved to be highly effective. Metallic cartridge cases were regarded as impractical for calibres of 6-in. or more, and the coast defence BL 6-in. gun Mk. VII proved quicker to operate than the QF 6-in. gun. Early BL equipments used the T-shaped friction primer, which was inserted into the breech screw once the gun or howitzer had been loaded. A lanyard was clipped to a ring in the primer and pulled to fire the gun. Poor obturation (sealing) of friction primers resulted in severe erosion of the vent by hot gases and they were replaced in service by cut-down rifle actions firing a powerful blank, and later by purpose-built percussion locks using firing tubes based on .303-in. rifle cartridges.

In the following listing the 'equipments' are placed in chronological order of introduction, a variant differing significantly from the original (such as the BL 8-in. howitzer Mk. VII) having its own entry.

BL 6-in. 30cwt siege howitzer

Introduced in 1896, the obsolescent BL 6-in. siege howitzer of 30cwt was the only equipment ready for operational service with the Siege Brigade in 1914. The brigade's six batteries took 24 to France and a further 90 were obtained and converted to take a standard 100lb 6-in. shell (instead of the special 120lb howitzer round). The howitzer saw service



BL 6-in. 30cwt howitzer of 6th Siege Battery, RGA, 1914-15. The large buffer springs of the BL 6-in. 30cwt are clearly shown in this photograph, as is the arm and volute spring linking the howitzer to its siege platform. (RAHT AL190.3.28)

Official nomenclature

Ordnance BL 6-in. 30cwt howitzer Mk. I
on carriage siege BL 6-in. 30cwt
howitzer Mk. I

Total weight of gun and carriage

3 ton 9cwt 0qr 5lb

Ammunition type

Separate loading BL

Calibre/Usual projectile type and weight

6in./HE, initially of 118.5lb, later 100lb.
Also Shrapnel and Star shell

Maximum range

5,200 yards on travelling carriage,
7,000 yards on siege mounting

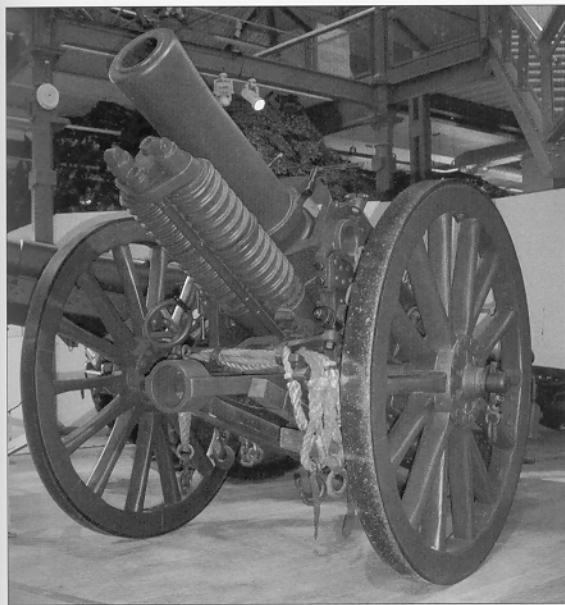

Immaculate BL 6-in. 30cwt howitzer on display at Firepower, the museum of the Royal Artillery, Royal Arsenal, Woolwich, London. (Author's photograph, reproduced courtesy of RAHT)

in all theatres of war, including the Dardanelles – the four howitzers of 14th Siege Battery RGA forming part of the divisional artillery at Cape Helles. A similar but lighter (6-in. 25cwt) equipment was adopted for use in India. The BL 6-in. 30cwt siege howitzer was typical of its time, having a limited amount of carriage recoil, the majority of the recoil force being absorbed by an arm linking the carriage to the platform and connected to a powerful volute spring. For high-angle siege work the wheels were removed from the carriage and a 'top carriage' fitted allowing the barrel to be elevated to near-vertical angles. The howitzer could also be fired from its carriage as a heavy field howitzer. This, however, significantly reduced the equipment's range and accuracy. The BL 6-in. 30cwt siege howitzer began to be replaced by a true heavy field howitzer, the BL 6-in. of 26cwt, from 1915.

BL 9.45-in. Mk. I siege howitzer

Although long considered obsolete in British service, four BL 9.45-in. howitzers (known as 'Quarter-to-ten' guns or 'Skoda Howitzers') were the only heavy siege howitzers actually in service with Siege Brigade in 1914 and, although not used operationally, they were retained for training.

The shortage of heavy howitzers had been a concern during the Boer War. Looking abroad for a solution, UK Government agents found four M1998 howitzers in stock at the Austro-Hungarian firm of Skoda, Pilsen. The British bought the howitzers in February 1900 and shipped them and 4,000 rounds of ammunition secretly via Gibraltar to South Africa. The howitzers were not required for any siege work and only fired a single round in action. After the Boer War they were shipped to China, where they again failed to contribute and were returned once more to the UK. Adoption of cordite instead of ballistite as propellant reduced the maximum range by 1,000 yards, while the limited depression of the mounting (maximum 63°, minimum 42°) gave them an immensely high trajectory at full charge, making it very difficult to shoot with accuracy or consistency at longer ranges. The howitzer's screw breech was sealed with a cup – effectively a reusable shell case that attached to the front of the breech screw – which was considerably less efficient than the BL system already in British service. Overall the 9.45-in. howitzer was seen as an unsatisfactory piece of ordnance, but the way it broke down for transport, and the style of the carriage, were developed into the siege mount for the 9.2-in. howitzer Mk. I and its derivatives. The BL 9.45-in. howitzer Mk. I was officially declared obsolete in 1920.

Official nomenclature	Ordnance BL 9.45-in. howitzer Mk. I on carriage siege BL 9.45-in. howitzer Mk. I
Total weight of gun and carriage	8 ton 11cwt
Ammunition type	Separate loading BL
Calibre/Usual projectile type and weight	9.45in./HE, 280lb.
Maximum range	7,650 yards

QF 4.7-in. field gun (See also *Field Army Artillery in this series*)

The only artillery pieces to emerge with credit from the Boer War were the famous 'Four-Point-Sevens' of the Naval Brigades. After the war, the Royal Artillery received some hundreds of QF 4.7-in. field guns, which it was not entirely sure it wanted or needed. The shell was lacking in hitting power and the field carriage tended to dig in at the trail, making the gun difficult to fire with accuracy. The Regular heavy batteries were soon re-equipped with the BL 60-pdr, a properly designed heavy field gun, but the Government had committed to provide the Volunteers with the QF 4.7-in. guns 'which have done such excellent service in South Africa', and these passed in due course to the Territorial Force. In the early stages of World War I, batteries of QF 4.7-in. guns were used to plug various gaps in the divisional artillery – substituting for field howitzers, for example. The QF 4.7-in. gun was withdrawn during 1917.

Official nomenclature	Ordnance QF 4.7-in. 'B' gun on carriage travelling QF 4.7-in. Mk. I
Weight of equipment	3 ton 15 cwt 19lb
Ammunition type	Separate loading QF
Calibre/Projectile type and weight	4.7in./HE, 46lb 9oz, shrapnel, gas
Maximum range	10,000 yards

BL 6-in. Mk. VII gun

At the height of the Boer War, Captain Percy Scott RN provided the Army with a 6-in. gun from the cruiser HMS *Terrible* on a wooden field carriage with sheet-iron wheels, similar to those he had designed for naval 4.7-in. guns sent ashore previously. The equipment was built over a weekend and in its first action the gun engaged and destroyed a Boer gun at a range significantly further than any Army field gun could achieve. Following the Boer War, trials continued in the UK using BL 6-in. Mk. VII guns on wooden 'Scott Carriages'. The Mk. VII was a powerful coast defence and naval gun, approved for service in 1898. The barrel was longer and the breech accepted a larger propelling charge than the earlier marks of 6-in. gun, and it was fitted with a quick-acting single-action breechblock. 'Scott Carriage Guns' did see action during



BL 6-in. gun Mk. VII – another view of *Bessie*, 43 Siege Battery, RGA, 1919. Note the distinctive 'flat' on top of the breech and the stepped, straight-edged profile of the barrel, which identify this as a Mk. VII. (RAHT AL317.122)

World War I, but a better solution was required, so steel box trail 'travelling' (actually field) carriages were constructed by the Royal Arsenal and various railway workshops. On firing, most of the recoil was transmitted directly to the carriage, which ran back onto wedge-shaped 'scotches' placed behind the wheels. The low carriage limited the gun's elevation, and hence the maximum range it could achieve, and the equipment was extremely heavy, limiting its mobility. Four different marks of carriage were built, depending on the type of cradle used, and each had a slightly differing maximum elevation. In addition to guns removed from coast defence, 84 new Mk. VII guns were manufactured. Two hundred and eleven BL 6-in. Mk. VII guns were re-lined and 44 were still in the field in 1918.

Official nomenclature	Ordnance BL 6-in. Mk. VII on carriage 6-in. Mk. II, III, V or VI
Total weight of gun and carriage	25 tons 4cwt 2qr
Ammunition type	Separate loading BL
Calibre/Usual projectile type and weight	6in./HE, 100lb
Maximum range	13,700 yards (carriage Mk. II)

BLC 6-in. siege gun

Breech-loading converted (BLC) 6-in. guns were old Mk. IV and VI 6-in. coast defence guns modified and modernised in 1902. New quick-acting single-motion breechblocks were fitted to replace the old 'three motion' ones (which had to be unscrewed, pulled back and swung clear to open) and the chambers were lengthened to accommodate more powerful propellant charges, bringing the guns' performance closer to that of the BL 6-in. gun Mk. VII.

Three four-gun batteries drawn from the coast defences were supposed to reinforce the Siege Brigade on mobilisation. Their guns were to be BLC 6-in. guns on 'carriages, siege, BL 6-in. gun, Mk. I'. The siege carriage was a rectangular base-plate, with a pair of wheels and a pedestal mount fixed to one end. On arrival at its position, this base, or 'holdfast', was lowered to the ground, the wheels removed and the barrel and cradle, which had travelled as a separate load, lifted onto the pedestal using a gyn (a three-legged lifting frame). Designed for use bolted to the ramparts of a fort or the deck of a ship, the rudimentary buffer absorbed only a portion of the gun's recoil, the rest being transmitted to the holdfast, which was secured with ground anchors dug in at the gun's 10, 12 and 2 o'clock positions and attached by wire hawsers. This arrangement was too static for the early fluid phase of World War I, and those BLC guns that did see action did so on box trail travelling carriages with traction engine wheels. Replaced in service by the Mk. VII gun, BLC 6-in. guns were converted into 8-in. howitzers from 1915.

Official nomenclature	Ordnance BL converted Mk. I/IV and Mk. VI/IV on carriage travelling 6-in. Mk. I
Total weight of gun and carriage	12 tons 1cwt
Ammunition type	Separate loading BL
Calibre/Usual projectile type and weight	6in./HE, 100lb
Maximum range	14,200 yards

BL 60-pdr Mk. I gun (See also *Field Army Artillery in this series*)

The BL 60-pdr Mk. I was approved for service in 1905, replacing the QF 4.7-in. gun in Regular heavy batteries. During World War I the gun also replaced the 4.7s of the TF batteries. At 4½ tons, it was at the upper limits of what could be considered field artillery with horses as the means of traction. To distribute the weight of the gun evenly between carriage and limber, the barrel and cradle could be slid to the rear. On the outbreak of war, a new Mk. II carriage was designed that was quicker and easier to produce but added a ton to the equipment's weight, abandoned the sliding barrel and cradle, and placed the 60-pdr beyond animal traction. However, it was found that if the barrel could be disconnected from the recuperator and slid back to its 'recoiled' position when moving, lighter wheels and axles could be used. This resulted in the carriage Mk. III (or Mk. II* if converted). In all, 1,756 60-pdrs were produced, of which 571 remained in service on various fronts in 1918. During the war, an alteration to the shape of the shell extended the gun's range from 10,300 yards to 12,300 yards. A total of 10,125,321 60-pdr rounds were expended on the Western Front. The Mk. I gun was superseded by the Mk. II during the inter-war period.

Official nomenclature	Ordnance BL 60-pdr gun Mk. I (I* or I**) on carriage field BL 60-pdr gun Mks. I, II, II* and III
Weight of equipment	Mk. I carriage 4 ton 8cwt, Mk. III carriage 5 ton 1qr.
Ammunition type	Separate loading BL
Calibre/Projectile type and weight	5in./shrapnel, HE, 60lb, smoke, gas
Maximum range	10,300 yards, 8 calibre radius head 12,300 yards

BL 9.2-in. Mks. I and II siege howitzers

It had always been intended that the BL 6-in. 30cwt howitzer should be accompanied by a heavier equipment, but efforts to develop an 8-in. howitzer stalled, and the Skoda 9.45-in. howitzer proved a disappointment. The coast defence high-angle RML 10-in. gun – a sort of anti-ship howitzer – had been suggested as an alternative, but the idea of using a muzzle-loader on a concrete mount in modern mobile warfare met

BOTTOM, LEFT *Mother*, the prototype BL 9.2-in. siege howitzer in action near Neuve Chapelle, November 1914. The original howitzer served throughout World War I, first with 8th Siege Battery RGA and later with 10th Siege Battery, RGA. The barrel was re-lined in 1917, returning to France in January 1918. *Mother* survived to serve as the model for the RA Memorial (see page 3) and the barrel is preserved on a production Mk. I siege carriage at the Imperial War Museum, Lambeth, London. The production mount differs from the prototype in small details, such as having an additional oil reservoir above the buffer, the elevating gear release differently located, and a slightly different arrangement of layers' platforms. (RAHT AL190.3.30)

BOTTOM, RIGHT Loading a 290lb HE shell. (RAHT AL190.3.29)



A1: BL 6-in. 30cwt Howitzer, 1st Siege Battery, RGA, France, September 1914



A2

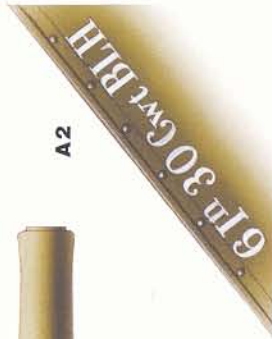

A3: BL 6-in. 30cwt Howitzer on top carriage, siege and platform

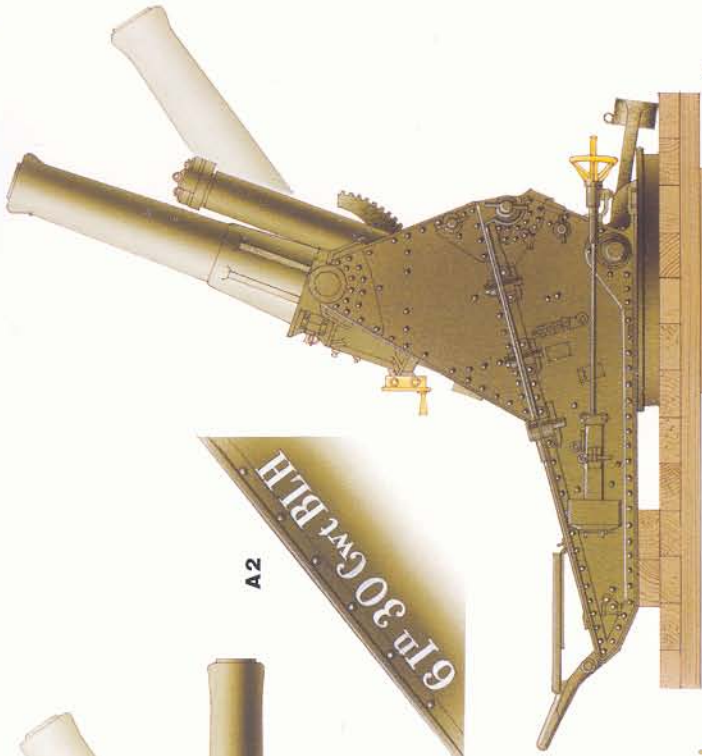

A5 AND A6: BL 6-in. Gun Mk. VII, 7th Siege Battery, France, 1916

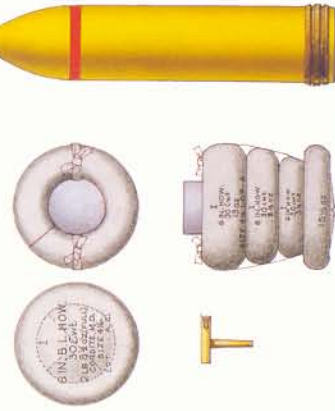
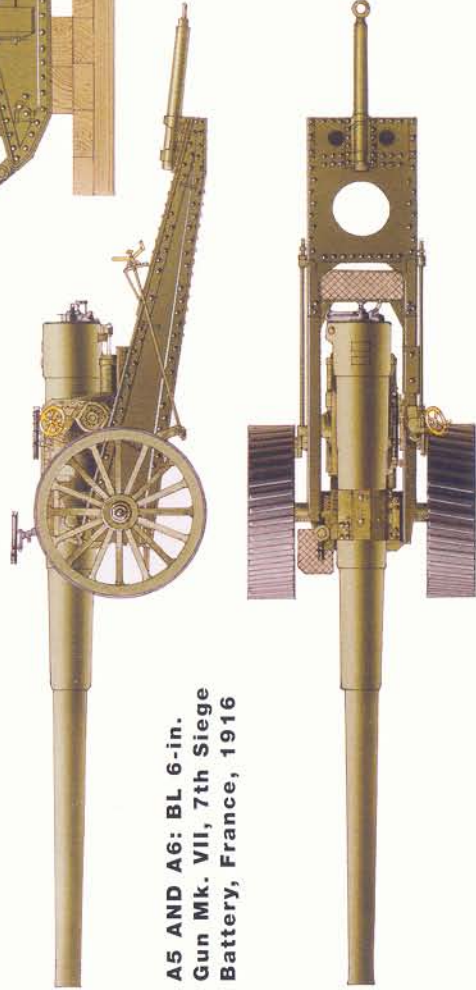

A4: BL 6-in. 30cwt ammunition

**B1 AND B2: BL 8-in. Howitzer Mk. VII, 135th Siege Battery, RGA,
Vimy Ridge, March 1918**

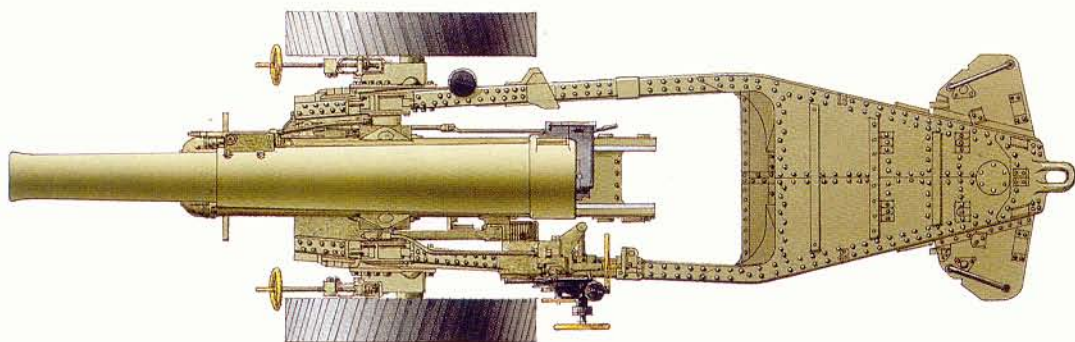
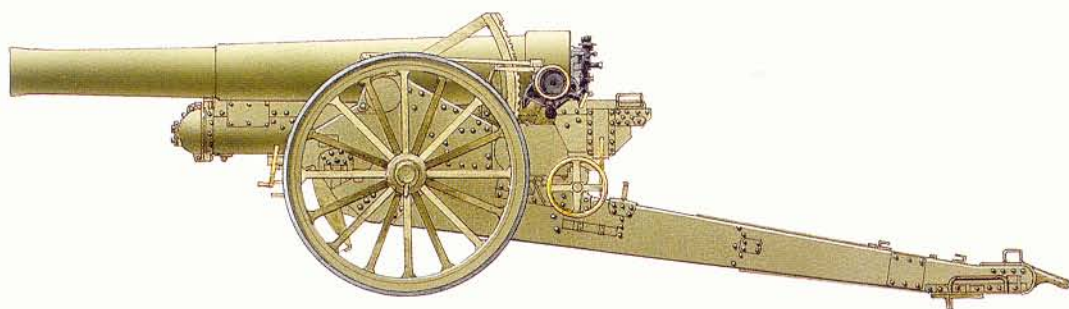
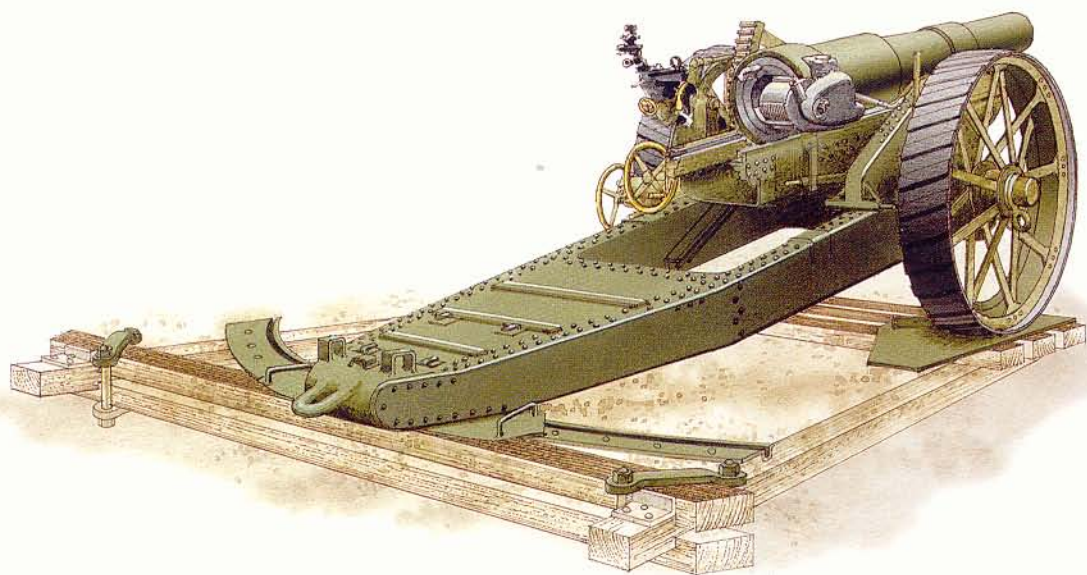

**C1 AND C2: BL 6-in. 26cwt Howitzer Mk. I, C Sub,
HAC (309th) Siege Battery, Ypres, April 1917**

C3: Girdle

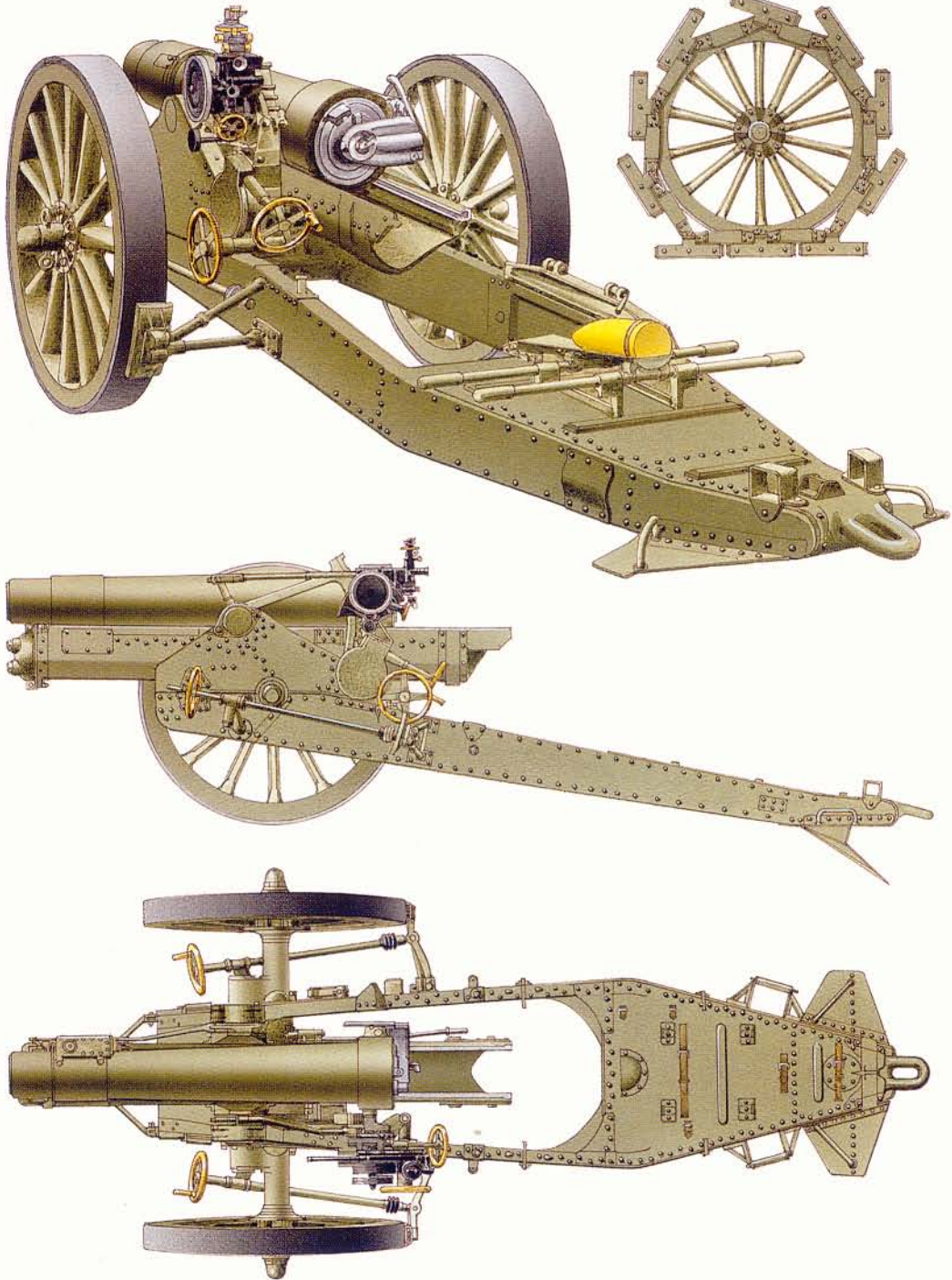

D1: BL 9.2-IN. SIEGE HOWITZER MK. I MOTHER, VIEILLE CHAPPELLE, OCTOBER 1914

D4: 9.2-in. howitzer cartridge

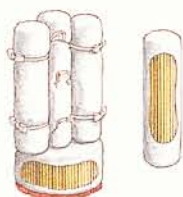

D3: 9.2-in. howitzer ammunition

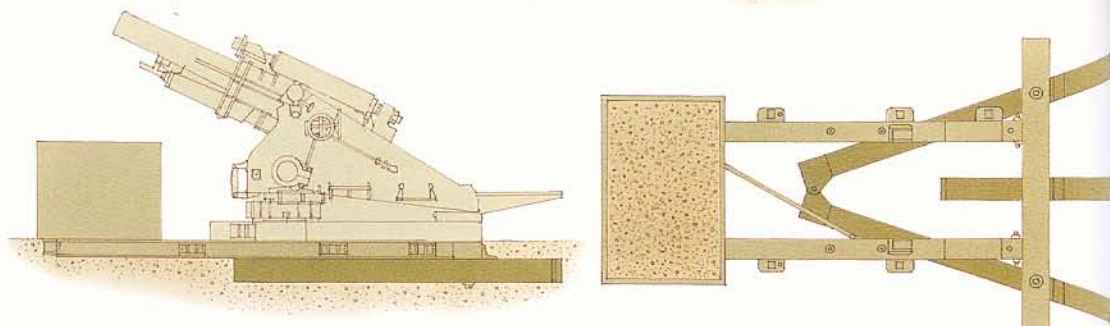
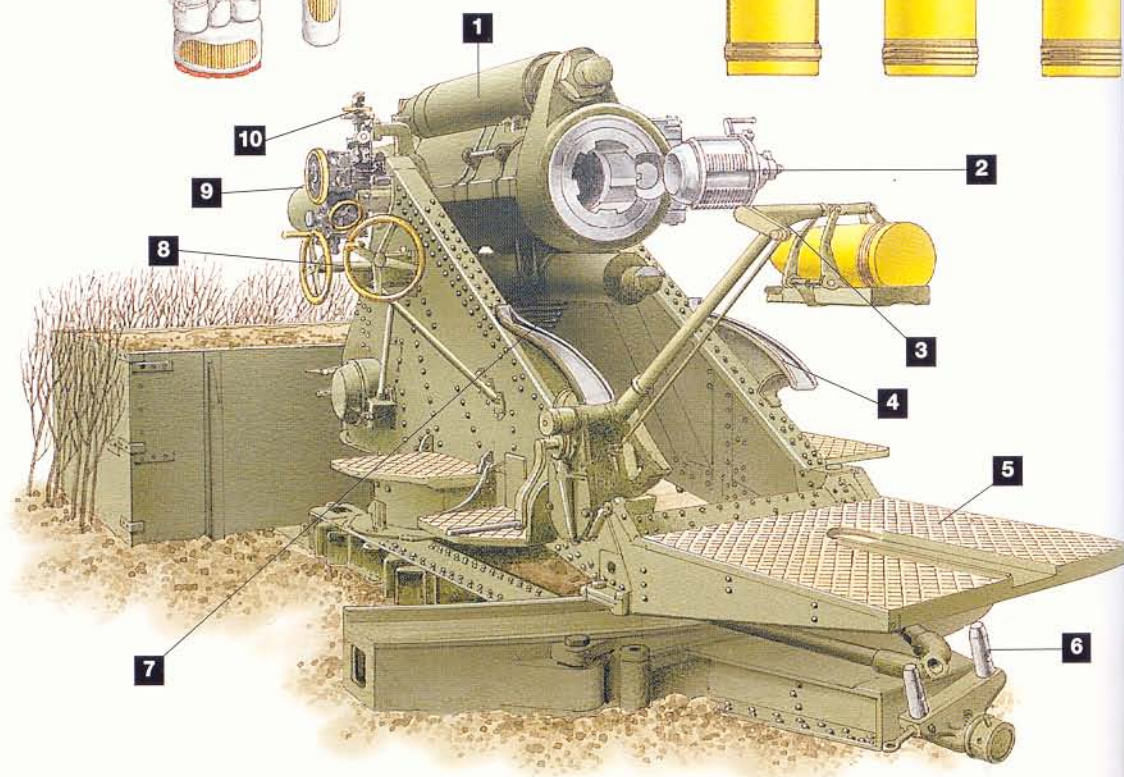

D5: Holdfast

E1: BL 9.2-in. Howitzer Mk. II, 154th Siege Battery, RGA, France, July 1917

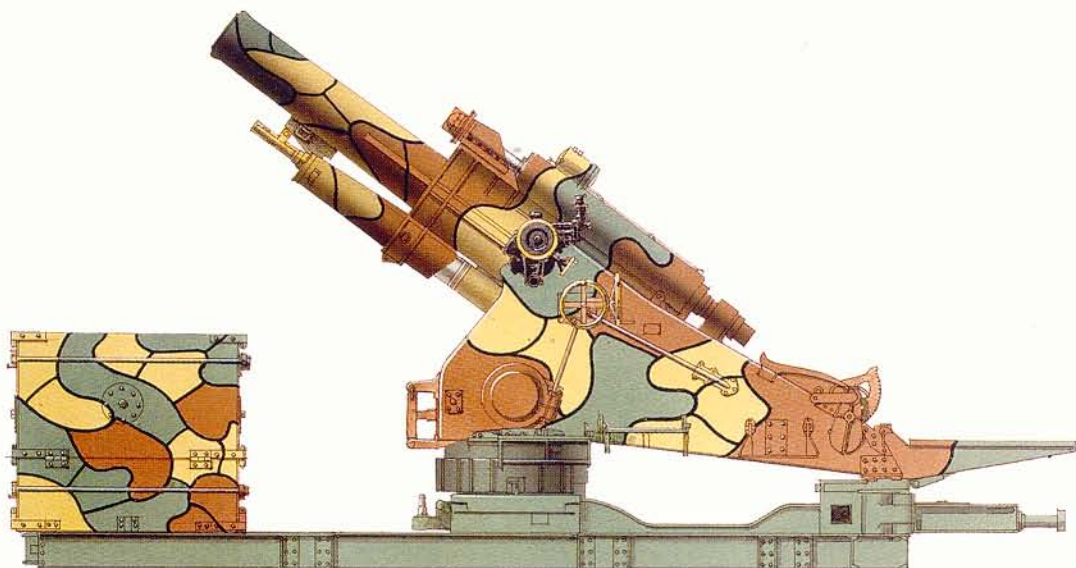

E2: BL 9.2-in. Howitzer Mk. II dismantled for transport

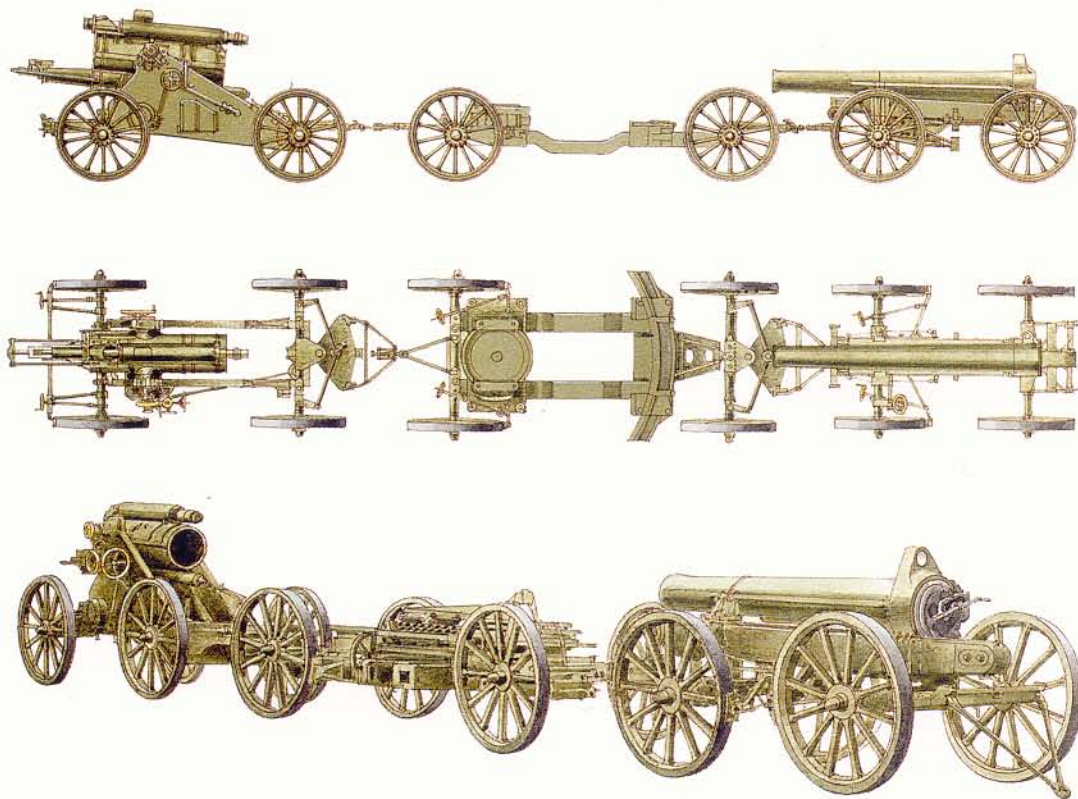

F1: BL 9.2-in. Railway Gun Mk. XIII, left section, 366th Siege Battery, near Dickebusch, 23 September 1918

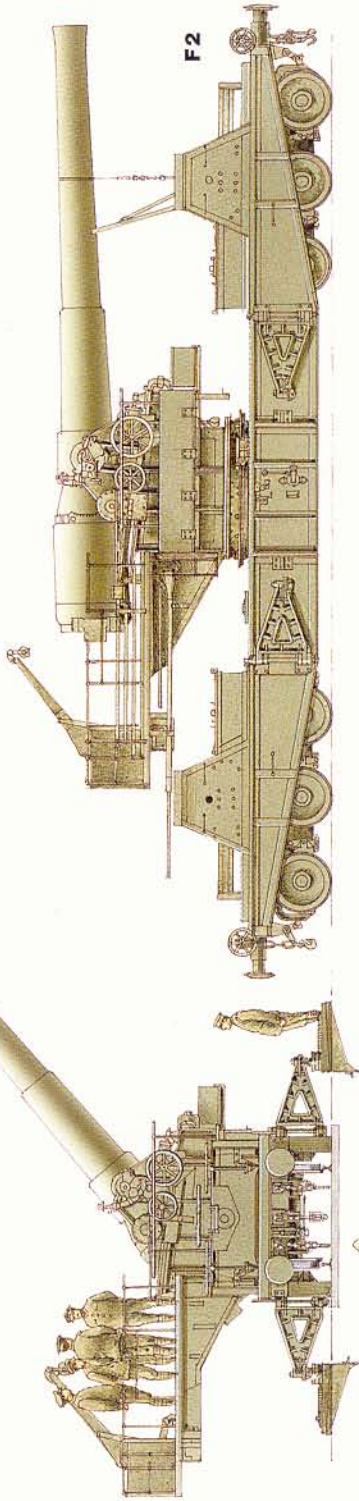

F2

F3: BL 12-in. Railway Howitzer Mk. V, Western Front, May 1918

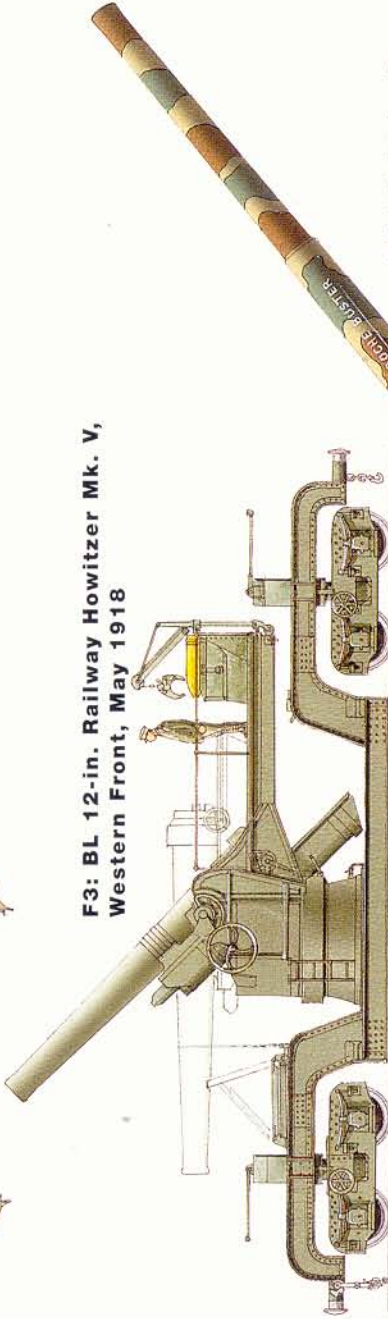

F4: BL 14-in. Gun, 471st Siege Battery, RGA, Maroeuil, August 1918

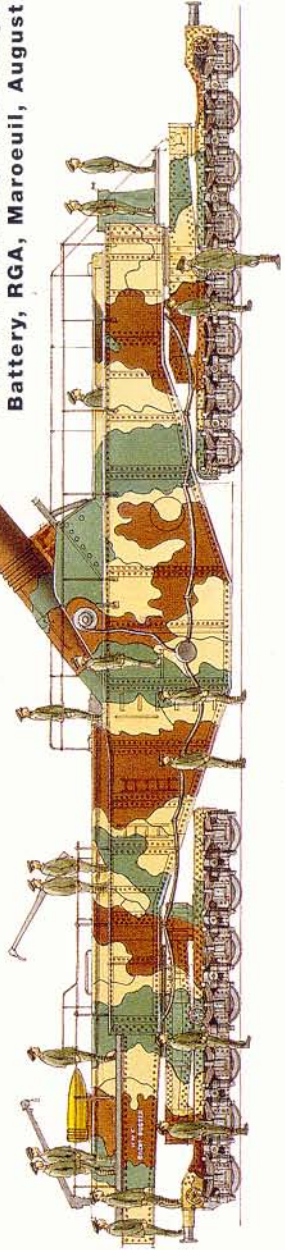

G1: Holt Caterpillar tractor towing BL 8-in. Howitzer



G2: 'FWD' lorry towing BL 6-in. Howitzer

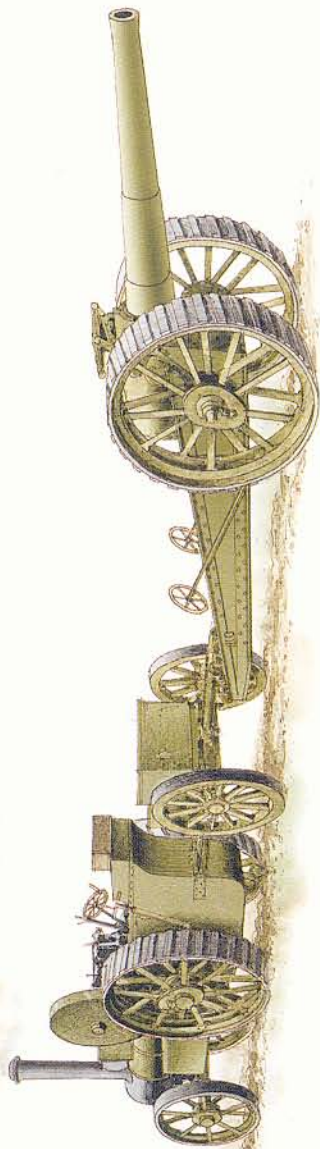
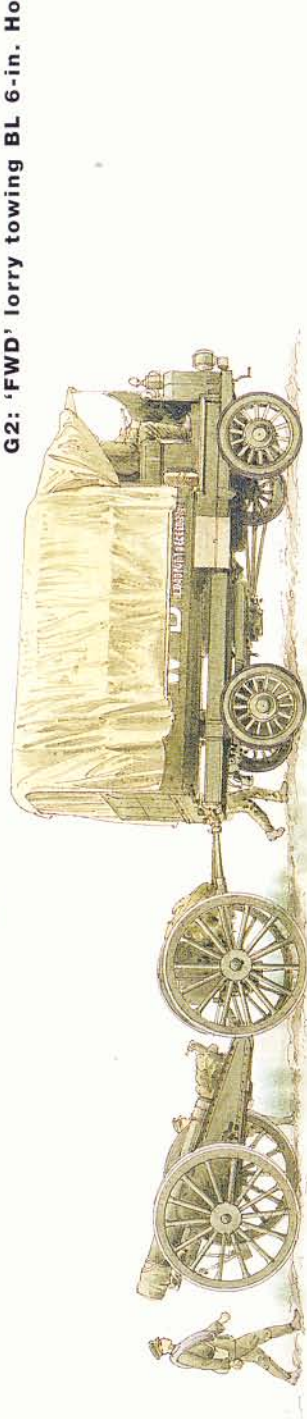

G3: Fowler traction engine towing 6-in. Gun

with a hostile response from the Chief Instructor Siege. It was not until 1912 that 'conditions' were issued for a new 'heavy mobile howitzer'. A prototype was delivered from the Coventry Ordnance Works in 1913 and taken for travelling and firing trials at Woolwich and Shoeburyness. The new experimental equipment retained the essential features of the Skoda 9.45-in., but was of 9.2in. – a calibre well established for coast defence and naval guns. Like the Skoda howitzer, the BL 9.2-in. siege carriage broke down into loads for transport, but the cradle remained on the carriage. To lighten the carriage load, the bed was carried separately, increasing the number of loads to three. In action the howitzer sat on a steel girder holdfast, which extended in front of the carriage and was fitted with a collapsible box filled with earth to act as a counterweight. Like the 9.2-in. coast defence gun, the howitzer used a hydro-pneumatic buffer and recuperator – the first time this system had been used in a mobile equipment. There was some doubt that the behaviour of the hydraulic fluid would be consistent across the wide range of climates experienced by British troops, and the system was very sophisticated, being 'variable' – limiting the recoil stroke when the barrel was near the vertical (and most likely to strike the ground) and allowing a very long stroke when the barrel was nearer horizontal (and most likely to recoil backwards). In the event it worked perfectly.

The BL 9.2-in. siege howitzer Mk. I was taken to Rhayader for trials in July 1914 and in a report dated the day before Great Britain declared war the officer commanding concluded: 'This equipment is a vast improvement on any other in use in the siege artillery, and is worth taking with an army.' The prototype, *Mother*, was in service in France in October 1914 (see Plate D), and 16 further equipments were ordered. In December 1916, a Mk. II howitzer was developed to achieve a range of 14,000 yards. Although it closely resembled the Mk. I equipment, the Mk. II was larger in many dimensions and about 3 tons heavier. The most obvious external differences were the cranked bedplate girders and lengthened barrel. The BL 9.2-in. siege howitzer Mk. II never supplanted the Mk. I. Eventually production ran to 512 equipments of the two marks, 62 of which were supplied to the allies. The howitzer remained in British Army service into World War II.



BL 9.2-in. siege howitzer Mk. II, *Dora*, of 154th Siege Battery, RGA, July 1917. Notable differences from the Mk. I howitzer are the profile of the barrel, the cranked bedplate girders (bottom centre) and the link bar from trunnion to buffer (top centre right). (RAHT AL1136.2)

Official nomenclature	Ordnance BL 9.2-in. howitzer Mk. I on carriage siege BL 9.2-in. howitzer Mk. I
Total weight of gun and carriage	13 tons 7cwt 1qr (plus 9 tons in earth box)
Ammunition type	Separate loading BL
Calibre/Usual projectile type and weight	9.2in./HE, 290lb
Maximum range	10,060 yards

Official nomenclature	Ordnance BL 9.2-in. howitzer Mk. II on carriage siege Mk. II
Total weight of gun and carriage	16 tons 4cwt (plus 11 tons in earth box)
Ammunition type	Separate loading BL
Calibre/Usual projectile type and weight	9.2in./HE, 290lb
Maximum range	13,935 yards

BL 8-in. Mks. I-V howitzers

The requirement for a BL 8-in. howitzer dated back to the end of the 19th century. It was only met in late 1914 when a Major M. L. Wilkinson, RGA, suggested that obsolete BLC 6-in. guns be shortened and bored out to 8-in. calibre to make howitzers. The guns came from the Royal Gun Factory (part of the Royal Arsenal, Woolwich) and were converted by Vickers. Cradles were of various naval and coast defence patterns and field carriages, similar to those built for 6-in. guns but rather higher to permit the greater elevation required of a howitzer (45° elevation and 5° depression), were built by the Great Western Railway workshops at Swindon. Limbers were built by the Midland Railway workshops at Derby. Ammunition for the 8-in. howitzer was manufactured by Rees Roturbo, a company with no previous experience of munitions. Nevertheless, the new howitzer, which was officially introduced into service in February 1915, performed 'splendidly', and 100 equipments were ordered. The first round of the 8-in. howitzer was fired in action by 19th Siege Battery RGA at Gorre (La Bassée Front) in May 1915. Mks. I-V differed according to the type of 6-in. gun converted:

BOTTOM LEFT Right section, 19th Siege Battery, RGA, in action – the first production BL 8-in. howitzers, Gorre, near Bethune, June 1915. (RAHT AL1148.5)

BOTTOM RIGHT early BL 8-in. howitzer. Note the prominent twin buffer-recuperator cases above the barrel and the stowage of the numerous handspikes. The howitzer appears to be straddling a railway track, probably during proof firing or trials. (Reproduced courtesy of RAHT)

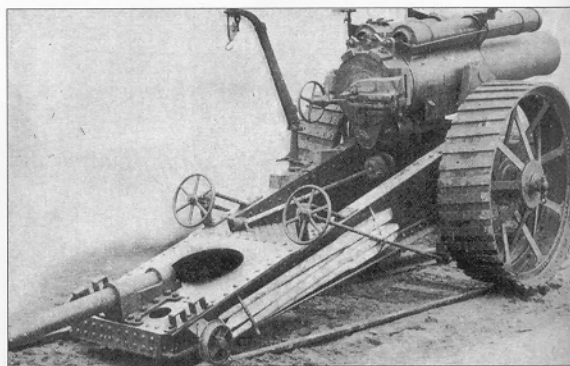

BL 8-in. howitzer Mk. I: BLC 6-in. gun Mk. I/IV
 Mk. II: BL 6-in. gun Mk. IV or VI
 Mk. III: As above, but with different pattern cradle
 Mk. IV: BLC gun Mk. I/VI adapted for Mk. IV carriage
 'B' wire Mk. V: QF 6-in. Mk. II (converted to BL)

Carriages varied according to the cradle used:

Carriage travelling BL 8-in. howitzer Mk. I:

Cradle from BLC 6-in. gun siege mount

Mk. II: Cradle from BL 6-in. gun P3 naval mount

Mk. III: Cradle from BL 6-in. gun central pivot coast artillery mounting. Position of elevating gear altered

Mk. IV: Conversion of the carriage, travelling, BL 6-in. gun Mk. I

Mk. V: As Mk. II, but with the cradle of BL 6-in. gun P2 naval mounting, to suit BL 8-in. howitzer

Mk. V

Although an effective stop-gap, BL 8-in. howitzers Mks. I-V were extremely heavy, and lacked efficient on-carriage recoil. They were replaced as soon as supplies of the Mks. VI and VII were available.

Official nomenclature	Ordnance BL 8-in. howitzer Mk. I-V on carriage travelling BL 8-in. howitzer Mks. I-V
Total weight of gun and carriage 1	3 tons 3cwt to 13 tons 11cwt depending on Mark
Ammunition type	Separate loading BL
Calibre/Usual projectile type and weight	8in./HE, 200lb, also gas
Maximum range	10,500 yards

BL 15-in. siege howitzer. The forward 'A' frame would not normally be seen when the gun was in action. The rear derrick was a shell hoist, used if the 1,450lb shells could not be slipped directly onto the loading tray from the special ammunition wagon.

(Reproduced courtesy of RAHT)

BL 15-in. siege howitzer

The Coventry Ordnance Works scaled up their successful BL 9.2-in. siege howitzer design to produce a 15-in. 'super-heavy'. The project came to the attention of the First Lord of the Admiralty, Winston Churchill, who in November 1914 ordered 12 equipments, which were operated throughout the war by detachments from the Royal Marine Artillery. Ten were sent to France and one was sent to Gallipoli, but could not be landed and was returned to France. At least one (Gun 5) was blown up by its detachment to prevent its capture in April 1918. BL 15-in. siege howitzers were less popular than 12-in. siege howitzers because of their shorter range, but where they could be emplaced to engage an enemy fortification – as at Thiepval in 1916 – the effect of the 1,450lb shells was 'rhythmical obliteration'. Six BL 15-in. siege howitzers remained in service at the Armistice, by which time 25,300 rounds of 15-in. howitzer ammunition had been expended.

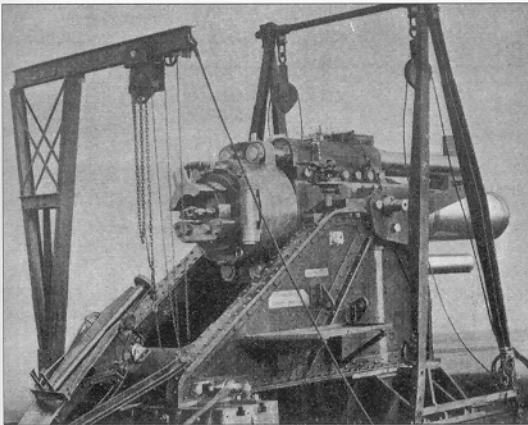

Official nomenclature	Ordnance BL 15-in. howitzer Mk. I on carriage siege BL 15-in. howitzer Mk. I
Total weight of gun and carriage	
Ammunition type	Separate loading BL
Calibre/Usual projectile type and weight	15in./HE, 1,450lb.
Maximum range	10,795 yards

BL 9.2-in. gun on railway mounting

The 9.2-in. gun entered naval service in 1879 in response to a new German 24cm calibre gun. It was subsequently adopted for coast defence use. When, in 1915, there was a desperate need for heavy long-range artillery on the Western Front, surplus BL 9.2-in. guns were provided, mounted on railway wagons, using old-fashioned Vasseur mountings, on which the upper part of the carriage travelled back and upwards along an inclined slide to absorb recoil. The mounts could only traverse 10° either side of the centre line, but the equipment could be traversed through a wider arc by moving backwards and forwards along a curved section of track. More serious was the lack of elevation, which was only 28° and limited the gun's range. In March 1916 the Elswick Ordnance Company designed a field modification kit that packed the carriage, allowing a maximum elevation of 35° to be achieved. Several marks of 9.2-in. gun were fitted to this mount, differing in details of construction, rifling and the shape of the chamber: BL 9.2-in. gun Mk. III*, IV, IVA, IV*, IVA*, VI, VIA, VIB, VIC, VIB* and VIC*.

In June 1916 the mounting, railway truck Mk. III on truck, railway Mk. II was approved for service. This consisted of an improved Vasseur mount on a turntable, with a platform for the detachment. The new railway truck was flat and designed to be lowered to the rails for firing. It was fitted with outriggers to permit traverse through 360° and elevation to 30°. The BL 9.2-in. Mk. X gun, the newest and most powerful available, was fitted to this mounting, along with a similar gun intended for the Australian coastal defences, which became the Mk. X T, and an export gun built by Vickers, which became the Mk. XIV. A specially designed 9.2-in. railway gun, from the Elswick Ordnance Company, heavier at the breech to allow the trunnions to be set further to the rear and achieve an extra 10° of elevation, was designated the Mk. XIII. Its mount, adapted to permit the extra elevation, became the Mk. IV. A conversion of 10-in. barrels to 9.2-in. was also attempted, but the heavier barrel needed to be mounted in the 12-in. railway mounting and never saw service. BL 9.2-in. railway guns expended 45,000 rounds of ammunition on the Western Front. All versions of the 9.2-in. railway gun were declared obsolete after the war, with the exception of the Mk. XIII guns on Mk. IV mountings, which remained in British service until 1945.

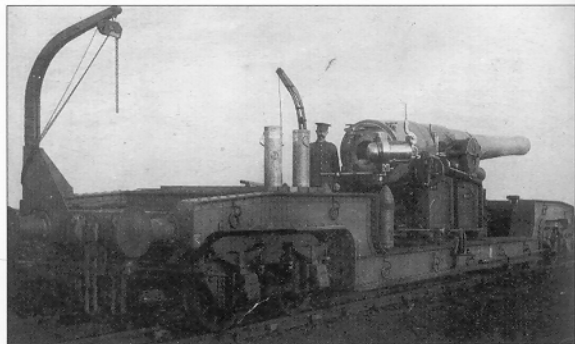

An early BL 9.2-in. railway gun on a Mk. I mounting, on a Mk. I railway truck. 44th Siege Battery, RGA, 1916. (RAHT AL1055.1)

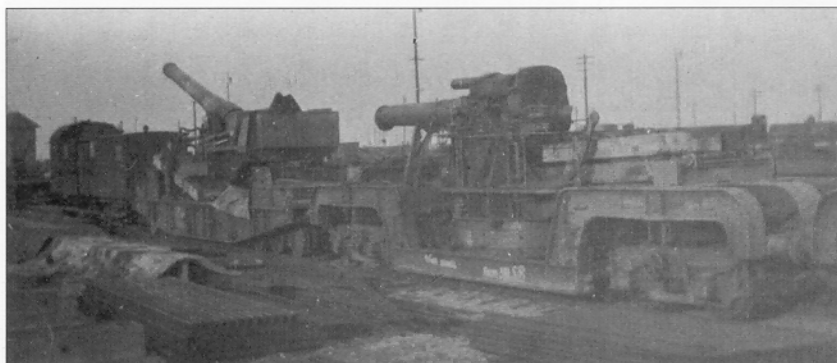

Demobilisation – a BL 9.2-in. railway gun Mk. II (left) and Eileen, a BL 12-in. railway howitzer Mk. III of 381 Siege Battery, RGA, (right), before being shipped from Herbesthal to the Ordnance depot, Chilwell, 1919. (RAHT AL1055.2)

Official nomenclature	Ordnance BL 9.2-in. gun Mk. III* and VI on mounting, truck BL 9.2 Mk. III and VI guns Mk. I on truck, railway Mk. I
Total weight of gun and carriage	Approx. 60 tons
Ammunition type	Separate loading BL
Calibre/Usual projectile type and weight	9.2in./HE, 380lb
Maximum range	21,000 yards

Official nomenclature	Ordnance BL 9.2-in. gun Mk. XIII on mounting, truck BL 9.2 gun Mk. IV on truck, railway Mk. II
Total weight of gun and carriage	86 tons 19cwt 2qr
Ammunition type	Separate loading BL
Calibre/Usual projectile type and weight	9.2in./HE, 380lb
Maximum range	22,600 yards

BL 6-in. howitzer of 26cwt

Work to produce a replacement for the BL 6-in. 30cwt howitzer was put in hand in January 1915, and the first BL 6-in. 26cwt howitzer was delivered in May. The new equipment was a true field howitzer, using a box trail and a variable hydro-pneumatic recoil mechanism and abandoning the old top carriage and platform siege artillery system. The only serious flaw with the howitzer was erosion of the primer vent, which was ended by replacing the friction tube system with a percussion lock. BL 6-in. 26cwt howitzers were sufficiently mobile to serve as heavy artillery alongside the 60-pdr field gun. By the end of 1916, 695 had been delivered and total production ran to 3,633 equipments, with 1,246 in service in various theatres in November 1918. Allied troops received 212, and 22,400,000 rounds were fired on the Western Front alone. A long-range lightweight shell was introduced in 1918, too late to see service in World War I. An excellent heavy field howitzer, the BL 6-in. of 26cwt remained in British Army service until 1945.

Official nomenclature	Ordnance BL 6-in. 26cwt howitzer Mk. I on carriage travelling BL 6-in. 26cwt howitzer Mk. I
Total weight of gun and carriage	3 tons 12cwt 2qr 22lb
Ammunition type	Separate loading BL
Calibre/Usual projectile type and weight	6in./HE, 100lb (86lb light shell from November 1918), also shrapnel
Maximum range	9,500 yards (100lb shell) 11,400 yards (86lb shell)

BL 12-in. railway gun Mk. IX, on the distinctive Vickers mounting. (Reproduced courtesy of RAHT)

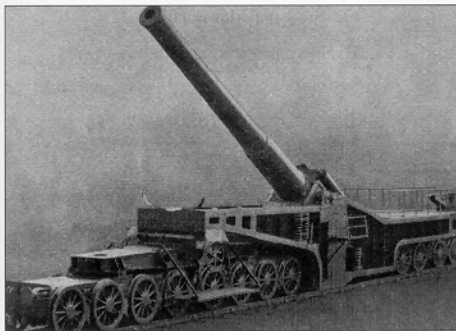

BL 12-in. Mk. IX gun on railway mounting

In September 1915 the Admiralty presented the Army with two BL 12-in. Mk. IX guns from HMS *Cornwallis*. Vickers produced two distinctive and slightly differing railway mounts with unusual inside-framed bogies, making the equipments resemble huge locomotives. The guns were in France by the end of 1915. These were followed by two more guns, on mountings built by the Elswick Ordnance Company. These Armstrong railway mountings (or mounting railway truck Mk. II) were businesslike, box-girder structures, slung between plate-framed bogies. The additional guns were in

action in August 1916. BL 12-in. Mk. IX railway guns remained in service until 1930.

Official nomenclature	Ordnance BL 12-in. gun Mk. IXWW on mounting railway truck 12-in. gun Mk. I and II
Total weight of gun and carriage	171 tons 3cwt 2qr with ammunition truck
Ammunition type	Separate loading BL
Calibre/Usual projectile type and weight	12in./HE, 850lb
Maximum range	32,700 yards

BL 8-in. Mks. VI, VII and VIII howitzers

In August 1915 work started to develop a new 8-in. howitzer with similar ballistics to the earlier Mks. I-V equipments, but lighter and with a more sophisticated recoil mechanism. Vickers supplied a prototype in March 1916. Essentially a scaled-up BL 6-in. 26cwt howitzer, the new equipment, the BL 8-in. howitzer Mk. VI, had a box trail, traversing top carriage and variable hydro-pneumatic recoil mechanism. It was also over 4 tons lighter than the earlier marks. This proved to be a mixed blessing as, even with on-carriage recoil, the howitzer tended to dig in at the trail, making it difficult to work and affecting accuracy. The solution was to issue a prefabricated platform, to which the howitzer was secured, in traditional siege artillery style (see Plate B). In June 1916 Vickers produced the BL 8-in howitzer Mk. VII, with a lengthened barrel, which increased maximum range from 10,000 yards to 12,500 yards. There were various minor variants of the Mk. VII, culminating in the Mk. VIII, which had a thicker barrel. A total of 678 Mks. VI, VII and VIII equipments were built, of which 236 were supplied to the Allies and 246 were in service at the end of the war. Mk. VI howitzers were declared obsolete in 1926 but Mk. VII's survived in British service until World War II, when they were converted into BL 7.2-in. howitzers. During World War I, 4,190,000 rounds of 8-in. howitzer ammunition were manufactured and a total of 4,900,000 rounds were fired on the Western Front.

Official nomenclature	Ordnance BL 8-in. howitzers Mks. VI, VII, VII*, VII** and VIII on carriage travelling BL 8-in. howitzer Mk. VI, VII and VIIa
Weight of gun	8 tons 10cwt 2qr 13lb (Mk. VI) 8 tons 17cwt 2qr (Mk. VII)
Ammunition type	Separate loading, BL
Calibre/Usual projectile type and weight	8-in./HE, 200lb
Maximum range	10,760 yards (Mk. VI) 12,300 yards (Mk. VII)



BL 8-in. howitzers Mk. VII of 81st Siege Battery, RGA, Belgium, shortly after the Armistice. Note the relatively clean lines, rectangular buffer-recuperator housing beneath the barrel and the camouflage paint on the howitzer in the foreground. (RAHT AL158.19)

BL 12-in. Mks. I, III and V howitzers on railway mounting

The success of the BL 9.2-in. howitzer led to demands for bigger versions, throwing heavier shells over the same or longer ranges. The Elswick Ordnance Company responded with a 12-in. howitzer, railway mounted for mobility. It was similar in operation to the 9.2-in. siege howitzer and based around stock components. The truck lowered onto the rails for stability and the howitzer could fire 20° either side of the centre line. Forty-six equipments were built, entering service as the 12-in. railway howitzer Mk. I from March 1916. Design work on an extended-range version was under way while the Mk. I howitzer was still under construction. This differed in having a longer barrel, with added weight at the breech to counterbalance the extra length. The mounting was very similar to that of the Mk. I, but suitably reinforced. As a road-mounted 12-in. howitzer had been produced in the interim, the extended-range 12-in. railway howitzer became the Mk. III. The Mk. III was followed by the Mk. V, which was capable of firing through a full 360°. The mounting was steadied by outriggers or cables attached to ground anchors. Unlike the Mk. III, the barrel was not weighted at the breech, relying instead on a strengthened elevating mechanism. The Mk. V was approved in July 1917. Thirty-five BL 12-in. howitzers Mks. III and V were built and examples of both types remained in service during World War II.

BL 12-in. railway howitzer Mk. I of 44th Siege Battery, RGA, at Meault, (near Albert), January 1916. Although the original picture is of poor quality, the stubby shape of the Mk. I barrel is quite apparent, as is the similarity to the BL 9.2-in. siege howitzer. (RAHT AL1055.6)

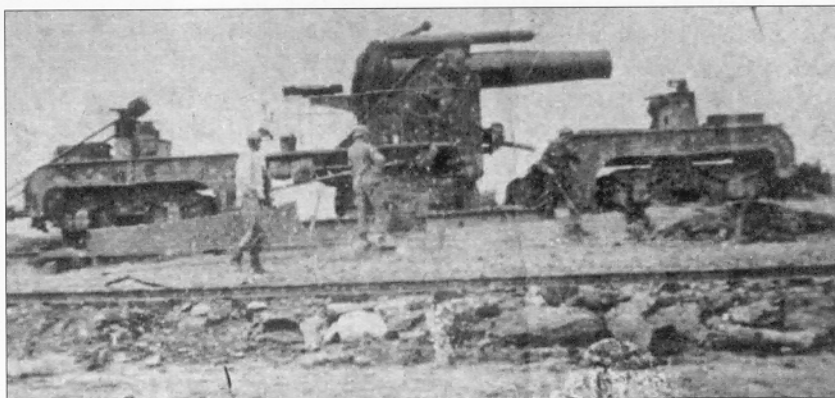

Official nomenclature

Ordnance BL 12-in. howitzer Mk. I on mounting BL 12-in. howitzer Mk. I on truck, railway, BL 12-in. howitzer Mk. I

Total weight of gun and carriage

57 tons 17cwt 1qr

Ammunition type

Separate loading BL

Calibre/Usual projectile type and weight

12in./HE, 750lb.

Maximum range

11,132 yards

Official nomenclature

Ordnance BL 12-in. howitzer Mk. III on mounting BL 12-in. howitzer Mk. II on truck, railway, BL 12-in. howitzer Mk. II

Total weight of gun and carriage

60 tons 15cwt

Ammunition type

Separate loading BL

Calibre/Usual projectile type and weight

12in./HE, 750lb.

Maximum range

15,000 yards

Official nomenclature	Ordnance BL 12-in. howitzer Mk. V on mounting BL 12-in. howitzer Mk. III on truck, railway, BL 12-in. howitzer Mk. III
Total weight of gun and carriage	75 tons 19cwt 0qr 15lb
Ammunition type	Separate loading BL
Calibre/Usual projectile type and weight	12in./HE, 750lb.
Maximum range	14,350 yards

BL 12-in. Mks. II and IV siege howitzers

While the Elswick Ordnance Company was working on the BL 12-in. railway howitzer, Vickers began work on a conventional siege howitzer of the same calibre. The BL 12-in. howitzer Mk. II, as it was designated, was truly a scaled-up 9.2-in. siege howitzer, looking virtually identical to the smaller equipment and being transported by similar means – albeit that there were six loads, and they required traction-engine wheels rather than wagon wheels to bear the weight. Eight equipments were in service by August 1916 and 14 were eventually built. A more powerful version, the Mk. IV, was developed in 1917. This had a longer barrel, twin shell hoists and a power rammer, the first time such a device had been used on a mobile equipment. Forty-three BL 12-in. howitzers Mk. IV were built and some were still serving during World War II.

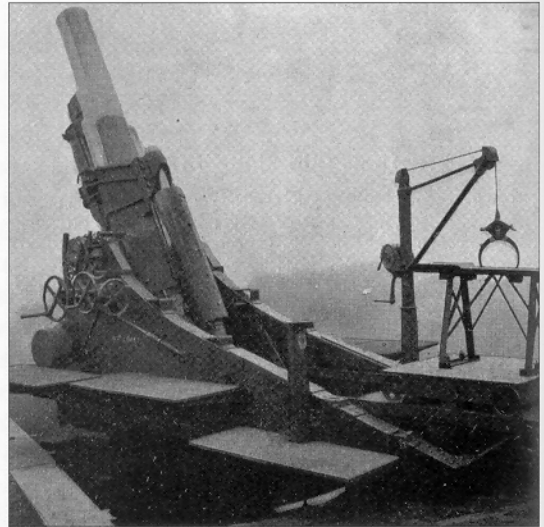

Official nomenclature	Ordnance BL 12-in. howitzer Mk. II on carriage, siege BL 12-in. howitzer Mk. I
Total weight of gun and carriage	36 tons 4cwt (plus 20 tons in earth box)
Ammunition type	Separate loading BL
Calibre/Usual projectile type and weight	12in./HE, 750lb
Maximum range	11,340 yards

BL 12-in. siege howitzer Mk. IV, the longer-barrelled version of the two road-mounted 12-in. howitzers. The similarity to the BL 9.2-in. is obvious – apart from size, the main differences are the long tapering rear to the carriage, the loading trolley and the style of the shell hoist, which could be mounted on either side.

BL 6-in. 35 calibre gun Mk. XIX

The major weakness of the early BL 6-in. gun carriages was that they were very low, limiting the guns' elevation and hence range. The 8-in. howitzer and 6-in. gun were closely related, and in October 1916 Vickers placed a long-barrelled BL 6-in. gun Mk. XIX on the high carriage of the BL 8-in. howitzer Mk. VI, creating – with the minimum of effort – an equipment capable of throwing a 100lb shell 16,500 yards, or 18,750 yards with a streamlined shell. The new gun was less than half the weight of its predecessor and, like the 8-in. howitzer, needed to be secured to a platform for firing. The BL 6-in. gun Mk. XIX never fully replaced the Mk. VII. In all, 310 Mk. XIXs were built during World War I.

Official nomenclature	Ordnance BL 6-in. gun Mk. XIX on carriage travelling Mk. 7a
Total weight of gun and carriage	10 tons 3cwt 2qr
Ammunition type	Separate loading BL
Calibre/Usual projectile type and weight	6in./HE, 100lb
Maximum range	18,750 yards (6 calibre radius head), 17,800 yards (4crh), 16,500 yards (2crh)

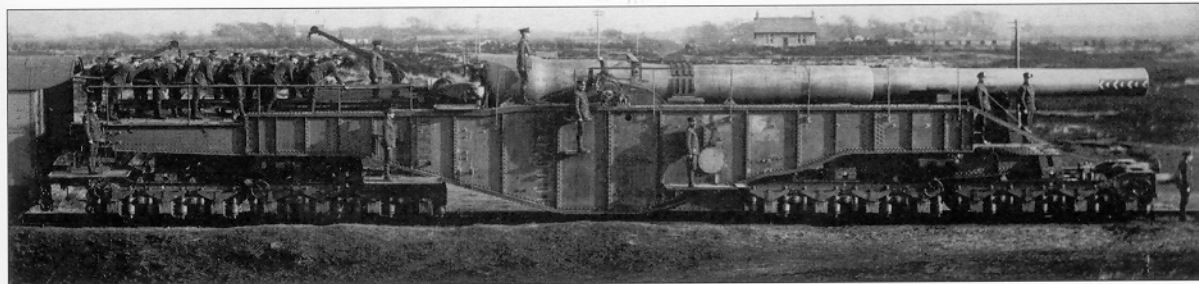

Loading *Scene Shifter* – the breech is open and 12 men are ramming a shell into the chamber. (RAHT AL587.3.2)

BL 14-in. gun on railway mounting

In August 1916 Armstrongs offered the War Office a pair of BL 14-in. guns from an undelivered Japanese order, to use as railway guns. 471st Siege Battery RGA was formed to operate the guns, which were named His Majesty's Guns *Boche Buster* and *Scene Shifter*. They arrived in Calais on 26 May 1918 and moved inland on the night of 6 June, *Scene Shifter* to Hazebruch and *Boche Buster* to Savy-Berlette. As the equipments were shipped incomplete, *Scene Shifter* only fired its first round, 'the King's Shot' (see Plate F3), on 8 August 1918. At the King's suggestion, the gun was fired at night to interdict German reinforcements travelling through the important railway junction at Douai. To avoid counter-battery fire the BC, Major S. M. Cleeve, had the gun moved, firing from three or four positions in the same night – an astonishing feat of mobility for an equipment weighing 248 tons. Of the 659 rounds dispatched to the two guns, *Boche Buster* had fired 243 by the Armistice. The guns were declared obsolete in 1926 and the barrels were scrapped. In 1940 both mountings were rescued from dereliction and re-barrelled (*Boche Buster* with an 18-in. howitzer, *Scene Shifter* with a 13.5-in. gun) and returned to service for anti-invasion duties in Kent.

Official nomenclature	Ordnance BL 14-in. gun Mk. III on mounting railway truck BL 14-in. gun and 18-in. howitzer Mk. I
Total weight of gun and carriage	248 tons
Ammunition type	Separate loading BL
Calibre/Usual projectile type and weight	18in./HE, 1,586lb, 14,00lb
Maximum range	34,600 yards (1586lb shell) 38,000 yards (1,400lb shell)

BL 60-pdr Mk.II field gun (see also *Field Army Artillery in this series*)

The BL 60-pdr Mk. II was a modernised 'heavy field' or medium gun, the first production batch of four being ready for service, but not shipped to the front, when World War I ended. The Mk. II entered service following World War I and remained with the British Army until 1944.

Official nomenclature	Ordnance BL 60-pdr Mk. II on carriage BL 60-pdr gun Mk. IV
Total weight of gun and carriage	5 ton 7cwt 2qr 8lb
Ammunition type	Separate loading BL
Calibre/Projectile type and weight	5in./HE, 60lb, shrapnel, smoke
Maximum range	15,500 yards

BL 18-in. howitzer

The 18-in. howitzer was, quite literally, the last word in British super-heavies. Designed to fit into the 14-in. gun mounting, the 18-in. was a straightforward BL howitzer, but on an exceptional scale. Five howitzers were manufactured and two complete equipments built – HMGs *Piece Maker* and *Gladiator* – just too late to see service in World War I. They were used briefly for training in the 1920s before being placed in storage. In 1940 both mounts were recovered from ordnance depots. *Piece Maker* was fitted with a 13.5-in. barrel and emplaced near Dover. On 10 December 1940 the mounting was damaged by German cross-Channel artillery fire. *Gladiator* (also fitted with a 13.5-in. barrel) joined *Piece Maker* in May 1941. Both mounts were scrapped after World War II, but one BL 18-in. howitzer survives, on a railway proof mount, in the collection of the Royal Artillery Historical Trust.



ABOVE The massive breech of an 18-in. howitzer – built to withstand a 262lb cordite propelling charge. Proof-fired in April 1919, 'L1', the last of five 18-in. howitzers built by the Elswick Ordnance Company, survives at Woolwich. The howitzer stands on mounting No. 10, a 95-ton railway proof sleigh built by the Royal Carriage Department in 1886. L1 spent much of its life on the ranges at Shoeburyness, where it was used to test various charges and projectiles, including 1,000lb aerial bombs. (Author's photograph, reproduced courtesy of RAHT)

Official nomenclature

Ordnance BL 18-in. howitzer gun Mk. I on mounting railway truck 14-in. gun and 18-in. howitzer Mk. I

Total weight of gun and carriage

250 ton 8cwt 1qr 11lb

Ammunition type

Separate loading BL

Calibre/Usual projectile type and weight

18in./HE, 2,500lb.

Maximum range

22,300 yards

MISCELLANEOUS WEAPONS

German Field Guns

When the stalemate on the Western Front was finally broken, it was difficult for siege artillery to move forward through the old front lines, and some batteries sent parties forward to locate and turn captured artillery. Between August and November 1918 135th Siege Battery manned captured 15cm howitzers and 10cm long-range guns, Royal Marines from 15-in. howitzer 'Gun 4' turned a battery of 15cm howitzers and a detachment from 85th Siege Battery did the same with a battery of 7.7cm field guns.

Mortars

The RGA spotted the potential of trench mortars very early, obtaining an improvised mortar used by the Japanese at Port Arthur. This was examined

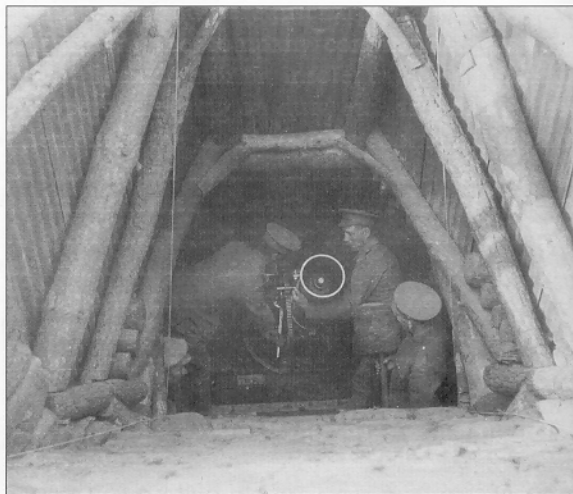

BL 6-in. 26cwt howitzer of 285th Siege Battery RGA, in a temporary position near Wytschaete Hospice, August 1917. The howitzer is painted in a dramatic 'dazzle' (disruptive) scheme of white or off-white stripes over the original khaki. (RAHT AL63.30)

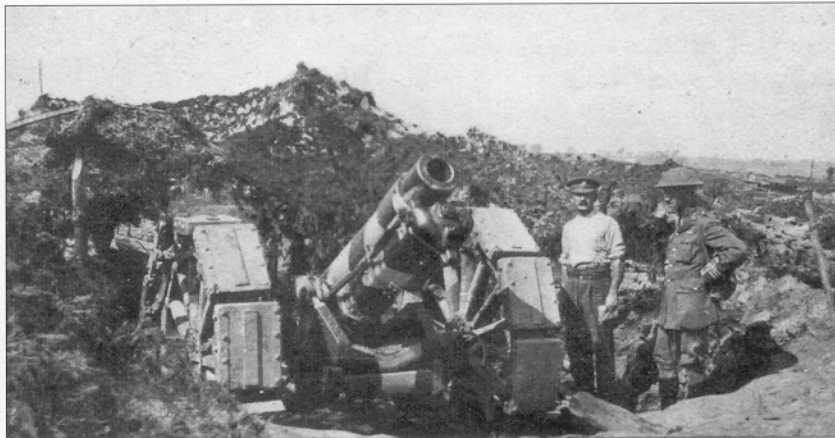

in the UK and in India, but failed to arouse much interest, and in 1912 the subject was dropped. Interest was revived in 1915 and various types of mortar introduced with infantry, RFA and RGA detachments.

COLOUR SCHEMES

The standard colour for British siege artillery on all fronts in World War I was 'khaki', a light brownish-green (Humbrol 'khaki drab' is a good modern equivalent for modellers) with an eggshell (rather than true matt) finish. Because of the immobility of siege artillery and the importance of avoiding aerial observation, once in the field – particularly on the Western Front – great use was made of camouflage schemes. These could be limited to applying a single colour to break up the distinctive shape of the barrel where it emerged from beneath the camouflage roof of the gun position, or could extend to covering every surface of the gun and mount with an elaborate multi-colour disruptive or 'dazzle' scheme. If the aim was to disguise the cylindrical shape of the barrel, the underside was painted white or off-white, with either a straight or, less frequently, a jagged edge where the colours met along the centreline on each side (see Plate G1). Dazzle schemes were generally made up of irregular patches of colour – dark green, reddish brown and sand would be a typical palette – separated by black lines. It is difficult to determine the exact colours from period monochrome photographs and, while guns in dazzle schemes were recorded by war artists, one must allow for some artistic licence and the passage of time. In any case, paint colour varied between batches and manufacturers, and shortages, caused by over-enthusiastic camouflaging of buildings at home, made it necessary to use inferior substitutes and paint produced locally, so considerable latitude can be allowed. The dazzle camouflage pattern shown for the 9.2-in. Mk. II siege howitzer (Plate E1) is based on a scheme painted onto a contemporary photograph by a serving gunner and preserved in the Royal Artillery Historical Trust collection.

To aid concealment, 'brightwork' (polished metal) was kept to a minimum and was confined to handwheels, breech, sights and similar components that needed to be kept free of paint, or which gained a natural polish from frequent use. Siege batteries took a rather more pragmatic approach to cleaning than did the horse or field artillery.

LEFT RGA gunners in a 9.45-in. mortar pit at the 3rd Army Trench Mortar School, St Pol, August 1916. (IWM Q1049)

Equipment was subject to what one gunner described as 'the unostentatious cleaning of the gun', concentrating on the moving parts, breech and bore. Under most conditions firing the gun, or a nearby gun, raised significant amounts of dust, so whether in position or being drawn along the road behind a team, caterpillar or FWD, guns would be covered with a layer of the local dust. Mud, however, was not tolerated, unless the gun was actually in action, or in the process of being moved in or out of position. 'Oiling round', as part of routine daily maintenance, would result in oily marks around the oiling/greasing points – all in all, the look was that of a well-used piece of heavy machinery. Mid-green paint came into use during the latter part of the war, and soon after the Armistice, guns were tidied up with plenty of exposed brightwork at the muzzle, breech and elsewhere. A high gloss bronze green was the standard finish during the inter-war years and remains the British Army's 'ceremonial' finish.

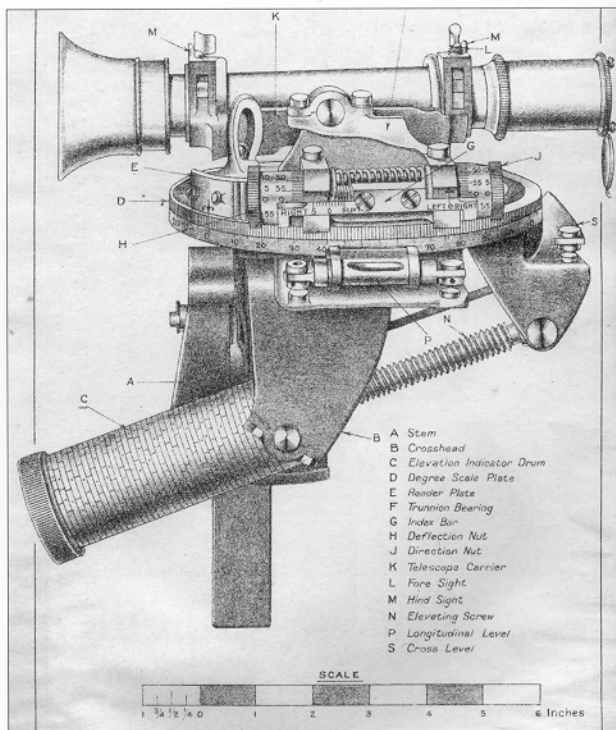

BIBLIOGRAPHY

- Growth and Development of the Royal Artillery During the War*, Woolwich (1919)
General Staff, Notes on Gunnery, London (1918)
Notes on Lectures, No. 2 RGA Cadet School, Maresfield (1917)
 Addison, G. H., *Work of the RE in the European War, 1914–19: Miscellaneous*, Chatham (1926)
 Bragg, L., Dowson, A. H. & Hemming, H. H., *Artillery Survey in the First World War*, London (1971)
 Bridland, T., *Field Gun Jack Versus the Boers*, Barnsley (1998)
 Buckland, C. S. B., *25th Army Brigade RGA on the Western Front in 1918*, Oxford (1940)
 Callwell, C. & Headlam, J., *The History of the Royal Artillery from the Indian Mutiny to the Great War: Volume I*, Woolwich (1931)
 Dunlop, J. K., *The Development of the British Army, 1899–1914*, London (1938)
 Headlam, J., *The History of the Royal Artillery from the Indian Mutiny to the Great War: Volume II*, Woolwich (1937)
 Hogg, I. V. & Thurston, L. F., *British Artillery Weapons and Ammunition, 1914–1918*, London (1972)
 Johnson, R. M., *29th Divisional Artillery War Record and Honours Book, 1915–1918*, Woolwich (1921)
 Kingham, W. R., *London Gunners*, London (1919)
 Venham P. & Fletcher, D., *Moving the Guns*, London (1990)
 Walter, F. W., *History of the 77th Brigade RGA*, London (1919)
 Walters, D. J. & Hurlle Hobbs, C. R., *The History of the 135th Siege Battery RGA*, London (1921)

The large and complicated No. 4 Dial Sight was used for indirect fire on earlier equipments, such as the BL 6-in. guns Mk. VII and early marks of 8-in. howitzer. It was replaced in service by the No. 7 dial sight, which was also used by the horse and field artillery. (Reproduced courtesy of RAHT)

COLOUR PLATE COMMENTARY



A1 AND A2: BL 6-IN. 30CWT HOWITZER, 1ST SIEGE BATTERY, RGA, FRANCE, SEPTEMBER 1914

1st Siege Battery, RGA, joined I Corps in France on 17 September 1914. The Battery was equipped with four BL 6-in. 30cwt howitzers. These were replaced with BL 6-in. 26cwt howitzers on 18 November 1916, and the battery was increased to six 'guns' on 24 February 1918.

The howitzer is shown in overall khaki finish (avoiding brightwork and elevating screws), with its designation painted on the right side of the trail.

A3: BL 6-IN. 30CWT HOWITZER ON TOP CARRIAGE, SIEGE AND PLATFORM

To get the best range, accuracy and rate of fire from the BL 6-in. 30cwt howitzer it was necessary to emplace it as a fixed siege piece. This required the platform to be assembled and dug in, the travelling carriage to be positioned and the barrel and wheels removed. The carriage was then lowered onto the platform, the top carriage fitted and the barrel replaced. This time-consuming process was not really justified by the comparatively small shell, and during World War I these howitzers were normally fired from their travelling carriages.

A4: BL 6-IN. 30CWT AMMUNITION

Ammunition for the BL 6-in. 30cwt consisted of a four-part cordite bagged charge and 118lb shrapnel or high-explosive (HE) shell. BL 6-in. 30cwt howitzers were subsequently modified to accept the 100lb shells used in 6-in. guns.

A5 AND A6: BL 6-IN. GUN MK. VII, 7TH SIEGE BATTERY, FRANCE, 1916

Originally equipped with the BLC 6-in. gun, 7th Siege Battery converted to the BL 6-in. Mk. VII. The Mk. I, II and three carriages differed chiefly in the amount of elevation (and hence range) that could be achieved. The Mk. III carriage illustrated had a naval pattern cradle and allowed the gun to be elevated to 22°. The gun was aimed using a No. 4 dial sight or a naval-style sighting telescope.

ABOVE 322nd Siege Battery, RGA, Deboli Carso, Italy, June 1917. A BL 6-in. 26cwt howitzer fires. Note the dugout (shelter) to the rear of the picture, the gunners' respirator gas mask haversacks, and the 'No. 3' standing-by with the rammer. (RAHT AL1158.60)

BELOW Sights of a BL 6-in. 26cwt howitzer on display at Firepower, the museum of the Royal Artillery, Royal Arsenal, Woolwich, London. Left to right: Range Disc, Range Handwheel (ribbed handwheel, bottom centre), Rocking Bar Sight (resembling rifle barrel, top centre), No. 7 Dial Sight (periscope arrangement, centre right), No. 4 Sighting Telescope (right). (Author's photograph, reproduced courtesy of RAHT)

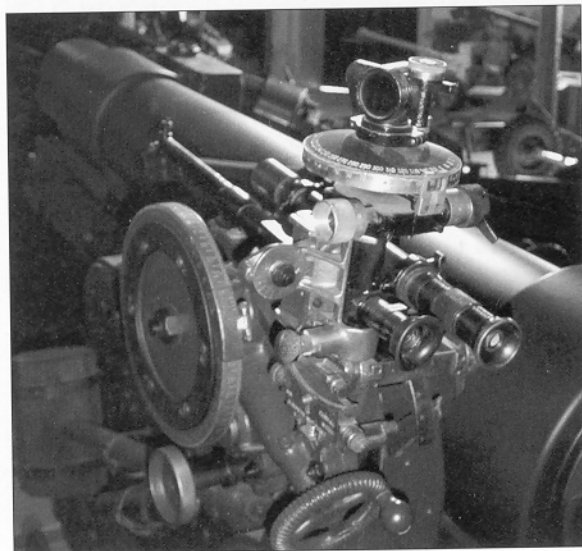



View from an OP. An 8-in. howitzer shell bursts on enemy positions at Bailiff Wood, near Contalmaison, June–July, 1916. (RAHT AL445.90)

B1 AND B2: BL 8-IN. HOWITZER MK. VII, 135TH SIEGE BATTERY, RGA, VIMY RIDGE, MARCH 1918

Designed to be as mobile as possible, the BL 8-in. howitzer had to be secured during firing if any sort of accuracy and consistency was to be achieved. This entailed digging in a wood and steel 'Vickers Platform' (the soil has been cut away to show the platform's construction), which supported the wheels and the base of the trail. Assembling the platform was backbreaking work and the worst possible situation was a major change in line (more than 30° from the centre of arc), necessitating the disassembly and taking-up of the platform to re-lay it so that the gun could be pointed in another direction.

C1 AND C2: BL 6-IN. 26CWT HOWITZER MK. I, C SUB, HAC (309TH) SIEGE BATTERY, YPRES, APRIL 1917

The Honourable Artillery Company entered World War I with two batteries of Horse Artillery and a half battalion of infantry. The regiment soon expanded to include two battalions of infantry and two more batteries of horse artillery. The idea of an HAC siege battery was conceived in mid-1916 and the battery landed in France on 26 April 1917. There can be no better illustration of the changing status of British siege artillery during World War I than that this elite volunteer regiment (the oldest in the British Army), which prided itself on its horse artillery, should form a siege battery. It should be noted, however, that HAC siege gunners insisted on wearing Royal Horse Artillery breeches rather than Royal Garrison Artillery trousers!

The battery was occupying positions 300 yards west of the Cloth Hall in Ypres during the second week of May 1917, when C Sub received a direct hit from German counter-battery fire. The most forward siege battery in its sector, the HAC battery remained in action until mid-June – by which time all of the battery's four howitzers had been 'knocked out'. The battery moved, was re-equipped and was back in action in early July.

C3: GIRDLE

Girdles were fitted to prevent the 1st Class B No. 10 wheel of the 6-in. howitzer sinking into soft ground. Girdles were only fitted when needed, as they would be worn out quickly on hard surfaces or when travelling over long distances. To fit the girdle the axle had to be jacked up and an articulated series of 'channels' fitted around the wheel. Once this was in position the 'shoes' were fitted (two at a time to keep the wheel balanced). When the girdles were fitted, the howitzer's brakes could not be used and were folded back against the carriage.

D1: BL 9.2-IN. SIEGE HOWITZER MK. I MOTHER, VIEILLE CHAPELLE, OCTOBER 1914

In August 1914 the prototype BL 9.2-in. siege howitzer was undergoing trials at Rhayader. It was in France, and in action for the first time near Vieille Chapelle, at 12.45pm on 31 October. The first target was an enemy heavy battery at a range of 7,850 yards. Fire was then switched to a second battery. The howitzer worked perfectly and the enemy batteries were both put out of action. *Mother* is shown, as first deployed, on the prototype mount, which differs in detail from the Mk. I mount on which the howitzer is displayed at the Imperial War Museum.

D2: BL 9.2-IN. SIEGE HOWITZER MK. I (LOADING)

The siege carriage allowed the howitzer to fire at angles between 15° and 55° and traverse through 60°. The elevating system was disconnected to lower the howitzer to 3° of depression for loading.

D3: 9.2-IN. HOWITZER AMMUNITION

Lyddite-filled HE shells were yellow; amatol or trotyl-filled shells yellow with a green band. Common pointed (CP) shells were light green to the shoulder. Filled shells had a red ring around the nose; those suitable for use in a hot climate were marked with a ring of crosses. Shells with an economy drive band were marked with two vertical black stripes.

D4: 9.2-IN. HOWITZER CARTRIDGE

The cartridge has been cut away to show the cordite charges. Full charge for the Mk. I howitzer was 10.9lb, for the Mk. II 22.75lb. Individual 'increments' could be removed to lessen the size of the charge.

D5: HOLDFAST

The holdfast was buried and the howitzer assembled on top.

The early holdfast consisted of the T-shape assembly only. The V-shape beam and short crosspiece was a later modification.

E1: BL 9.2-IN. HOWITZER MK. II, 154TH SIEGE BATTERY, RGA, FRANCE, JULY 1917

The BL 9.2-in. howitzer Mk. II was larger and more powerful than the Mk. I equipment. This howitzer, named *Dora*, was delivered to 154th Siege Battery in July 1917. Khaki when delivered, *Dora* was later painted in this disruptive 'dazzle'-pattern camouflage, which was recorded, in colour, by 178857 Gnr Thomas William Lee.

E2: BL 9.2-IN. HOWITZER MK. II DISMANTLED FOR TRANSPORT

Both marks of BL 9.2-in. howitzer broke down into three loads for transport: the body and cradle, bed, and barrel. A similar system, but with traction-engine wheels, was used for the BL 12-in. howitzer. The loads could be moved individually by teams of heavy horses, or *en train*, as one load, behind a traction engine or Caterpillar tractor. The parts of the earth box and holdfast were secured on the bed of the siege carriage for transport.

F1 AND F2: BL 9.2-IN. RAILWAY GUN MK. XIII, LEFT SECTION, 366TH SIEGE BATTERY, NEAR DICKEBUSCH, 23 SEPTEMBER 1918

The gun is shown ready for action at St Hubertushoek, on the eve of the Fourth Battle of Ypres. Moving the 9.2-in. guns of 25th Army Brigade forward depended on the 109th Railway Construction Company, Royal Engineers, repairing the railway line to Dickebusch and laying spurs from which the guns could be fired.

BL 15-in. howitzer of the Royal Marine Artillery. The detachment has gone to great lengths to hide their large and highly immobile equipment. Apart from hessian drapes and foliage, the howitzer has been painted with two colours of camouflage over the original khaki. (RAHT AL1163.25)



A black-outlined three-colour 'dazzle' scheme (see HMG *Boche Buster* below) was also used on these guns. As the Mk. XIII fired from a static position, unlike earlier 9.2-in. railway guns, they were frequently heavily camouflaged, with the railway mounting being covered with garnished camouflage netting.

F3: BL 12-IN. RAILWAY HOWITZER MK. V, WESTERN FRONT, MAY 1918

The howitzer is shown in standard khaki finish.

F4: BL 14-IN. GUN, 471ST SIEGE BATTERY, RGA, MAROEUIL, AUGUST 1918

On 8 August 1918, King George V arrived to inspect HMG *Boche Buster*. The King ordered the gun fired at 1430hrs, the target being Douai railway station, which had hitherto been out of range to British artillery. According to an English lady resident during the German occupation, 'The King's Shot', coming completely out of the blue, struck a German troop train, causing 200-300 casualties. Although the line was repaired, the Germans never used the station again.²

Photographs show *Boche Buster* in a 'dazzle' scheme, interpreted as dark green, sand and reddish-brown outlined with black.

G1: HOLT CATERPILLAR TRACTOR TOWING BL 8-IN. HOWITZER

Not only did Caterpillar tractors replace the immense number of horses that would have been required to move the hugely expanded British siege artillery by traditional means, but they also enabled siege equipment to become as mobile as heavy artillery. The Holt could move an entire 9.2-in. siege howitzer *en train*, a couple of 6-in. howitzers hooked together, or an 8-in. howitzer and limber. Holts were also very useful for getting smaller guns, such as 6-in. howitzers, into difficult positions across poor ground.

The gun has an irregular light patch under the muzzle to break up its silhouette when pointing out from a camouflaged position.

G2: 'FWD' LORRY TOWING BL 6-IN. HOWITZER

The American-designed four-wheel drive or 'FWD' lorry transformed the mobility of the heavy batteries, finally giving 60-pdr guns and 6-in. howitzers the means to operate as part of the field army. The lorries could carry 50 rounds of howitzer ammunition. They travelled 'choked with stores of one sort or another, 10ft planks, handspikes, spades, tins of grease, great rolls of camouflage',³ the detachment clinging on as best they could. Some would travel on the limber and two more on the trail of the gun as 'brakesmen', ready to jump off and walk (or run) behind the gun, controlling the brakes as it went downhill.

G3: FOWLER TRACTION ENGINE TOWING 6-IN. GUN

Traction engines had become established as a means for towing heavy guns during the Boer War. The illustration shows a Fowler 'Road Locomotive' towing a BL 6-in. gun and limber in a siege park in France in late 1914. Although long associated with siege artillery, steam traction engines, with their long start time from cold and distinctive clouds of smoke and steam, were not really suitable for tactical use, and were superseded by internal combustion-engined Caterpillar tractors.

² RAHS *Proceedings*, vol. 5 No. 1

³ Kingham, 1919.

INDEX

Figures in **bold** refer to illustrations

ammunition 5, 8, 11, 11, 20, 22, 24, 24, 34, 35, **35**, 36, 37, 38, 40, **41**, **D3**
charges 17, 21, 45, 46, **A4**, **D4**
preparation for firing 16
'Shell Scandal' 11
Army Service Corps 8, 12, 13

Boer War 4, 7, 9, 21, 22, 47
'brightwork' 43, 44, 45

camouflage and colours 16, **38**, 43, **43**, 44, 45, 47, **47**, **A1**, **A2**, **F3**, **F4**, **G1**
'dazzle' scheme 15, 43, 43, 47, **E1**, **F4**
carriages 4, 8, 9, 10, 21, 22, 23, **D2**
cleaning duties 16-17, 43-4, 45
coast defence batteries 5, 6, 23, 33
coast defence/naval guns 3, 4, 5, **6**, 7, 10, 11, 19, 20, 22, 23, 33, 35, 36, 37
counter-battery fire 16

'Field Army Trend' 4, 13
field artillery 4, 4, 6, 19, 24
field guns
BL 6-in. Mk. XIX 11
BL 60-pdr Mk. II 3, 4, 19, 24, 37, 41
development and service 8, 41, 47
QF 4.7-in. 3, 4, 19, 22
development and service 22, 23
QF 6-in. Mk. II 20, 34
friction primers 20

garrison artillery/companies 5, 6
German field guns/howitzers 36, 42
girdles 5, **C3**
guns
BL 6-in. 35 calibre Mk. XIX 40
development and service 40
equipment 40
BL 6-in. Mk. IV/VI 23, 34
BL 6-in. Mk. VII 19, 22, 23, 35
development and service 20, 22-3, 22, 45, 47, **G2**
equipment 19, 22, **22**, 23, **44**, 45, **A5**, **A6**
BL 60-pdr Mk. I 3, 4, 8, 19, 24, 37
development and service 4, 24, 47
equipment 24

Heavy Artillery Groups 14
'heavy field' batteries 4, 5, 6, 7, 14, 47
heavy (siege) brigades 4, 5
holdfasts 23, 33, 46-7, **D5**, **E2**
Honourable Artillery Company 12-13, 46, **C1**, **C2**
howitzers 5, 18-19
BL 6-in. 25cwt 5, 13, 21
BL 6-in. 26cwt Mk. I 5, 8, 11, 11, 19, 21, 37, 38, 45
development and service 8, 8, 18, 37, **43**, **45**, 46, **C1**, **C2**, **C3**
equipment 5, 37, **45**, 46, **C3**
BL 8-in. Mk. I-V 12, 23, 34-5, 38
development and service 16, 34, **34**, 46, 47, **G1**
equipment 34, 34, 35

BL 8-in. Mk. VI/VI/VII 11, 12, 38, 46, **B2**
development and service 8, 38, **38**, 46, 47, **G1**
equipment 38, **38**, 40, 46, **B1**
BL 18-in 11, 42, **42**
development and service 42
equipment 42, **42**

limbers 13, 16-17, 24, 34, 47, **G2**

medium brigades 5
mortars 18, 19, 42-3, **42**
mountain batteries 3, 4
mountings/platforms 3, 4, 5, 9, 10, 11, 20, 21, **24**, 35, **36**, 38, 46, **A3**, **B1**, **D1**

railway guns
BL 9.2-in. Mk. I-X T 36, 37
development and service 36, **36**
equipment 36, **36**
BL 9.2-in. Mk. XIII/XIV 11, 36, 37, 47, **F1**, **F2**
development and service 36, 47, **F1**
equipment 36
BL 12-in. Mk. IX 11, 12, **37**, 38
development and service 37-8
equipment 37, **37**
BL 14-in. 10, 11, 12, 41
development and service 41, **41**, 47, **F4**
equipment 41, 41
railway howitzers
BL 12-in. Mk. I/III/V 10, 11, 12, 39-40, 47
development and service 14, 15, **36**, 39, **39**, 47, **F3**
equipment 39, **39**
railway mountings/trucks 11, 36, **36**, 37, 37, 39, 41, 41
railway wagons/workshops 34, 36
recoil mechanisms 10, 10, 19, 23, 33, 34, 34, 35, 37, 38, **38**, 45, 47, **A5**, **A6**, **D2**, **E2**

recuperators 10, 19, 33, **34**, **38**, **D2**
RML guns/howitzers 9, 10, 24
Royal Arsenal, Woolwich 23, 34
Royal Artillery 3-4, 3, 7, 12, 22, **24**, 43
Royal Engineers 11, 12
Royal Field Artillery 3, 43
Royal Garrison Artillery 3-4, 4, 6, 7, 43
see also siege batteries
Royal Horse Artillery 3, 46
Royal Marine Artillery 7, 35, 47

'scotches' 10, 23
shell hoists 35, 40, **40**, **D1**
siege artillery 3, 4, 6, 8, 9, 13
siege batteries 4, 5, 6-8, 11, 12-13, 14-15, 16, 17, 20, 21
1st 45, **A1**, **A2**
6th 7, 20
7th 45, **A5**, **A6**
8th 24
10th 24
14th 21
19th 33, 34

44th 36, 39
81st 38
85th 42
135th 12, 16, 42, 46, **B1**, **B2**
154th 33, 47, **E1**
285th 43
309th (HAC) 12-13, 46, **C1**, **C2**
322nd 45
366th 47, **F1**, **F2**
381st 36
444th 14
471st 41, **41**, **F4**
personnel and duties 4, 6, 8, 13-14, 14, 16-17, 18, **34**, 41, 45, 47, **F1**, **F4**
Siege Brigade 5, 6-8, 20, 21, 23
siege guns
BLC 6-in. 23, 34, 45
development and service 23
equipment 23
siege howitzers
BL 6-in. 30cwt 5, 7, 10, 11, 19, 20, 21, 24, 37, 45, **A4**
development and service 5, 7, 17, 20-1, 20, 45, **A1**, **A2**, **A3**
equipment 19, 45, **A3**
BL 9.2-in. Mk. I/II 3, 3, 21, 24, 24, 33, 34, 35, 39, 40, 46, 47, **D1**, **D2**, **D3**, **D4**
development and service 10, 24, 33, 33, 36, **36**, 46, 47, **D2**, **E1**
equipment 10, 24, 33, **33**, 36, 46-7, **D1**, **D2**, **D5**, **E2**
BL 9.45-in. Mk. I 5, 9, 21, 24, 33
development and service 5, 9, 9, 10, 21
equipment 9, 9, 10
BL 12-in. Mk. II/IV 10, 35, 40, 47
development and service 8, 40
equipment 40, 40
BL 15-in. 10, 35
development and service 35, 35, 47
equipment 35

targets: location of/firing on 6
'aeroplane shoot' codes 16
'aiming point' line of fire 6
'clock face' target indication 6
dial sights 44, **44**, 45, 45
'Exact Method' 13
firing methods 6, 12, 13, 17
flash-spotting/sound-ranging 12
OPs 5, 6, 11-12, **12**, 13, 16, 46
plotters 13, **13**
rangefinders 6
sighting devices 6, 13, 16, 45, 45
'surveying-in' duties 11
triangulation 12, 13
Territorial Force 6, 12-13, 22, 24
towing/transport 3, 4, 7-8, 9, 10, 12, 13
'FWD' 3-ton lorry 9, 13, 47, **G2**
Gun Carrier Mk. I 8-9, 8
heavy horses 3, 4, 5, 7-8, 9, 24, 47
steam traction engines 7, 8, 47, **G3**
tractors 8, 12, 47, **G1**
Volunteers 6, 12-13, 22, 46, 47, **C1**, **C2**
volute springs 20, 21

The design, development, operation and history of the machinery of warfare through the ages

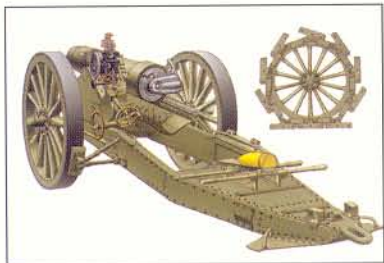

Full colour artwork

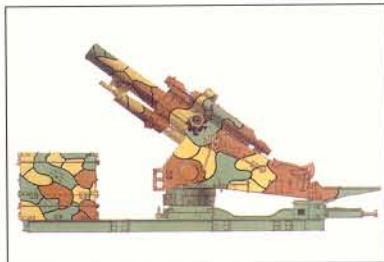

Unrivaled detail

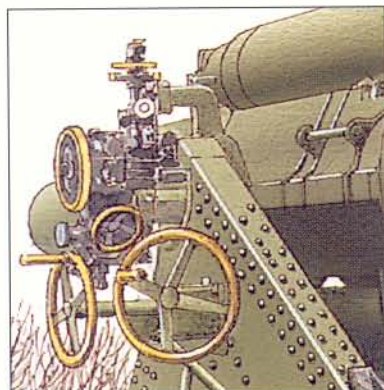

Cutaway artwork



Photographs

British Artillery 1914–19

Heavy Artillery

World War I is often deemed to have been 'a war of artillery', and British heavy artillery played a vital part in destroying the German trenches and providing invaluable cover for advancing troops on the Western Front. This book details the huge guns of the Royal Garrison Artillery, including the 6-in. siege gun and howitzer, the 8-in. howitzer, the 12-in. railway and siege howitzer and the infamous 9.2-in. breech-loading siege howitzer. Camouflage and enemy battery locations and transport are covered, as well as tactics used and how the guns were developed and manned.

OSPREY
PUBLISHING

www.ospreypublishing.com

ISBN 1-84176-788-3



9 781841 767888