

THE T-34 TANK



Steven J. Zaloga and James Grandsen

Colour plates by

Steven J. Zaloga and Mike Chappell

Published in 1980 by
Osprey Publishing Ltd
Member company of the George Philip Group
12-14 Long Acre, London WC2E 9LP
© Copyright 1980 Osprey Publishing Ltd

This book is copyrighted under the Berne Convention. All rights reserved. Apart from any fair dealing for the purpose of private study, research, criticism or review, as permitted under the Copyright Act, 1956, no part of this publication may be reproduced, stored in a retrieval system, or transmitted in any form or by any means, electronic, electrical, chemical, mechanical, optical, photocopying, recording or otherwise, without the prior permission of the copyright owner. Enquiries should be addressed to the Publishers.

ISBN 0 85045 341 0

Filmset in Great Britain
Printed in Hong Kong

Bibliographic Note

The main sources used in this book were numerous Soviet and Polish corps and brigade histories, published over the past decade. It would be pointless to list them here not only because they are not generally available, but also because of the language barrier they present to most readers. Unfortunately, there is no detailed study of the development of the T-34 available either in English or Russian.

For a more detailed historical study, the authors highly recommend John Erikson's superlative *The Road to Stalingrad* (Harper & Row, 1975), the finest study of the Red Army during World War II to have appeared in English; its single flaw is that the second volume, *The Road to Berlin*, has not appeared as of this writing.



Introduction

As the machine gun had dominated trench fighting on the Western Front in the Great War, so the tank ruled the steppes of the Eastern Front in 1941–45. No tank was more successful there than the legendary ‘tridsatchetverka’,* the T-34 medium tank. The engineering brilliance of the T-34 design gave the Red Army a solid technical bedrock on which to rebuild its shattered armoured forces after the 1941 débâcle. It ruled the battlefield for two bitter years of fighting; and even when it was eventually challenged by the heavier Tigers and Panthers in 1943, it was able to hold its own through progressively improved versions such as the T-34/85. Its simple, robust construction was well suited to the needs of mass production and it was manufactured in larger numbers than any other tank of World War II. In fact, more T-34s were manufactured from 1941 to 1945 than the combined number of British and German tanks produced during the whole war, and

The T-34 Model 1940 came as a rude shock to the Germans in the summer of 1941. Its armour was largely invulnerable to German tank guns, and this machine was only knocked out by a shot through its thinner rear armour.

this in spite of the fact that Soviet heavy industry was smaller than that of either nation. The T-34 fought in every major battle in which the Red Army was engaged during the ‘Great Patriotic War’, and saw combat service in a great majority of the conflicts of more recent decades.

With such a prodigious outpouring of vehicles, it would be impossible to present a detailed technical history of the T-34 in all its variants in this short book. Likewise, its combat record is so completely intertwined with the whole vast history of the Russo-German War that this story can barely be scratched here. The aim of the authors is to offer a selection of brief glimpses taken from major actions during the war. They are not necessarily representative of the conduct of the war as a whole, and in fact the authors have consciously sought out accounts of decorated Soviet tankers where photographic evidence was available to illustrate the text and to prepare the colour plates. It is hoped that this approach will help in some small measure to lift the veil of anonymity from what has long been, to Western readers, a faceless war.

*The diminutive form of the Russian for ‘34’, and the popular Russian nickname for this tank.

Conception

In September 1936 the first boatloads of 50 Soviet T-26 light tanks and their crews disembarked at Cartagena to take part in the Spanish Civil War. Eventually, these would be followed by more than 800 other armoured vehicles, including BA-10 armoured cars and BT-5 'Betushka' fast tanks. The war in Spain gave Soviet military engineers an opportunity to test their vehicles against contemporary German and Italian designs fighting with Franco's Nationalist forces. The T-26 and BT-5 were armed with a 45mm gun which easily dispatched the machine gun-armed Nationalist PzKpfw Is and L-3 tankettes, but their thin armour proved vulnerable to the new German Rheinmetall 37mm anti-tank gun. Soviet crews were critical of the balky M-5 aero engine used in the BT-5, and felt that the alternative tracked or wheeled propulsion system was useless.

Soviet designers at the Kharkov Locomotive Works (KhPZ No. 183) under Mikhail Koshkin took their suggestions to heart in designing the *Betushka's* replacement. The new design would be thickly armoured to proof it against the latest in anti-tank guns; it would be powered by the excellent new V-2 diesel; and it would be fitted with a potent new gun capable of defeating an enemy tank with as thick a skin as its own. The resulting T-32 prototype of 1939 had simple, elegant lines fostered by Tarshinov's well-angled armour layout. The Russian tank losses in the Finnish campaign of December 1940 prompted the addition of even more armour. The up-armoured version was finally unveiled in 1940 as the *T-34 srednii tank* (medium tank) and accepted by the Red Army for mass production. The T-34 was not without its teething problems or detractors, and in fact was nearly shelved. Its transmission was capricious, its original L-11 gun was inadequate, and it was as expensive as three T-26 light tanks. Yet the more far-sighted officers within the upper ranks of the Red Army recognized the design as a really revolutionary advance in tank engineering which would set the pace for the rest of the world's armies. By the spring of 1941 the 'bugs' in the powertrain had been corrected, and the assembly lines at KhPZ were beginning to switch over from the T-34 Model 1940, with the ineffective L-11

gun, to the T-34 Model 1941 with the long barrelled F-34 gun. The original 45mm thick welded turret was joined on the assembly lines by a 52mm thick cast turret for both the Model 1940 and the Model 1941.

Brilliant as was the creation of the Soviet military engineers, the picture in the armoured force itself was not so bright. Until 1939, the Red Army's tanks had been divided between large tank corps with an establishment of 660 tanks, and smaller brigades and regiments serving as support units for the infantry and cavalry. At the time, the Red Army adhered to a progressive view of the tank force as a major offensive tool in military strategy. With the execution of the armoured forces' chief advocate, Tukhachevskii, during the murderous purges of the late 1930s, more conservative forces under the leadership of men like D. G. Pavlov and G. I. Kulik took over, scattering the large formations into smaller brigades. These brigades were still formidable in size, having 258 T-26 or BT tanks in the standard tank brigade, and 156 T-28s in the medium tank brigades; but their rôle was completely subordinate to the infantry. Soviet military doctrine stagnated as the cold wind of the purges crept down everyone's back, and Stalin's old cavalry cronies from the 1920 war reigned supreme in their reactionary ignorance.

The stunning victories of the German Panzer divisions in France in May and June of 1940 greatly shocked Soviet military leaders; and, not to be outdone, they began re-forming the armoured force once again. The basis was to become the new and massive mechanized corps with two tank and one motor rifle division, each totaling 1,031 tanks and 36,000 men. Each tank division was to receive 63 KV heavy tanks, 210 new T-34 medium tanks and 102 new production T-26s and BT-7M light tanks. As if this weren't ambitious enough, they decided to form no less than 29 of these corps, besides additional independent formations. This would have required 16,600 new model tanks at a time when there were only 5,500 new tanks available, even counting the T-26s and BT-5s.

By the outbreak of the war, seven mechanized corps had been formed more or less completely, thirteen more were in the process of forming and



The early mechanized corps which fought in the Brody-Dubno battles were equipped with a mixture of vehicles like this T-34 Model 1941 with the new long-barrelled F-34 gun, entrenched in the foreground, and the older BT-8TU in the background. (Charles Kliment)

at least four more were nominally in existence. Most were 'paper' formations at best, and even the complete corps were in fact very short of new model tanks, and had to make do with older T-26s and BT-5s. The officer cadres were a mere ghost of what they had been five years before; the purges had left most of the best officers either dead or rotting away in the *gulags*. There were only 20–40 per cent of the officers needed for the corps and divisional staffs. Although the Red Army could boast of having more tanks than the rest of the world combined, they were in dismal shape. Of the 23,000 tanks in existence, 29 per cent required major repair work for which there were no spare parts, and 44 per cent required major rebuilding for which there were neither the parts nor the facilities. There were only 39 per cent of the trucks, 44 per cent of the tractors and 29 per cent of the repair vehicles needed for the new corps already in existence.

T-34 production was below the goals set, but by the outbreak of war 1,225 had been produced, about 900 of which were in the troops' hands. The

Wehrmacht at the time had about 965 PzKpfw III and 439 PzKpfw IV medium tanks. There were serious ammunition shortages for the T-34's 76mm gun, and most crews had only recently been issued their vehicles. Very few crews had any more than a few hours' training on the T-34, and there were few if any joint manoeuvres at corps or divisional level. Some corps had received a handful of T-34s, while others received none at all and had to rely on worn-out T-26 'sparrow shooters'. The T-26 and BT-7 were certainly no worse than the ghastly little German PzKpfw I or the marginally better PzKpfw II. Their main problem was their wretched state of repair. Maj.-Gen. N. V. Feklenko's 19th Mechanized Corps had only two T-34s, Mostovenko's 11th Mechanized Corps had 24, and many of the rest had none.

Operation 'Barbarossa'

On 22 June 1941 the Wehrmacht struck. German pincers raced deep through eastern Poland, and the Red Army's half-formed mechanized corps entered the field to challenge them. The biggest encounter loomed up in the southern region, where von Kleist's 1st Panzer Group of Army Group South raced past Berestechko towards the railway junction at Rovne. There were five Soviet mechanized corps in the area, the 8th, 9th, 15th, 19th and 22nd Mechanized Corps. The 8th Mechanized Corps should have been in good shape with its 600 tanks, of which 170 were T-34s or KVs. Moreover, Ryabyshev's corp had in its ranks the 34th Tank Division, which was the best in the Red Army and the unit that usually paraded in Moscow at the May Day celebration. Unfortunately, it was not concentrated and only 210 of its tanks were in the area. Rokossovskii's 9th Mechanized Corps had only one of its divisions, and its 300-odd tanks were all BT or T-26 pea-shooters. Karpezo's 15th Mechanized Corps had 135 T-34s or KVs, but Feklenko's 19th Mechanized Corps had only a single partial division with 160 tanks, of which only two were T-34s. Kondrusev's 22nd Mechanized Corps was little better off, and its only modern vehicles were 31 KV-2s without any ammunition.

On 25 June the South-Western Front commander, Gen. Kirponos, ordered the corps to contain and destroy the Panzer wedge. For the next four days, the five Soviet corps slugged it out with four German Panzer divisions as the Russians tried to link up at Dubno. The battle at Brody-Dubno was the largest single tank battle of the war before 1943. The German advance was slowed and the Panzer divisions involved were weakened. The diary of Col.-Gen. Halder, Chief of the German General Staff, remarked: 'The Army Group South is advancing slowly, unfortunately suffering considerable losses. The enemy acting against the Army Group South is reported to be directed with firmness and vigour. The enemy is constantly moving up fresh forces against our Panzer wedge.'

Although they had inflicted heavier losses on the Germans than at any other point in Operation

'Barbarossa', the Soviet units were battered beyond repair. The élite 34th Tank Division was encircled and wiped out by the 16th Panzer Division. By 29 June the battle began to peter out. In the fighting, the 15th Mechanized Corps had lost 119 tanks, 58 of these for lack of parts or fuel. By 1 July the 8th Mechanized Corps had only 140 tanks left and only 20-25 rounds per tank. By 7 July the 9th Mechanized Corps was down to 64 tanks and the 22nd Mechanized Corps was down to twenty. Most units had lost over half their tanks to mechanical failure and were threatened with losing most of the rest from lack of fuel.

The attacks had faltered for a variety of reasons. The most important factor was the experience of the German crews. Only a fraction of the Russian tanks were radio-equipped, and therefore tactics were inevitably centred around rigid geometrical formations. The crews followed their troop or platoon commander and directed their fire against the targets his tank pointed out. The more experienced German crews easily took advantage of the limitations of these tactics. Operationally, the mechanized corps were poorly co-ordinated. Field radios at command level were few in number and unreliable. In spite of the bravery and tenacity of the Russian attacks, the Soviet units were badly mauled.

None of the other mechanized corps managed to strike the German armoured salients in as co-ordinated a fashion as at Brody-Dubno. Major tank actions flared up at Shauliya, Alitius, on the rivers Dvina and Berezina and outside Minsk, but the results were always the same. The Germans took losses, at times heavy, but inexorably pushed on. Long columns of Soviet tanks littered the roadways, scuttled for lack of parts or lack of fuel, or destroyed by marauding German aircraft. By the end of July, the mechanized corps had all but ceased to exist, and with them most of the Soviet Union's 23,000 tanks.

The T-34 had little impact on the course of these actions and does not figure as prominently in German reports of the period as did the heavier KV tank. Its notoriety would come later in the year. Its lack of impact was in large measure due to the poor state of training of most of the new crews, and the diffusion of the T-34s amongst dozens of small units in meagre quantities. The



In the summer of 1941 the first new independent tank brigades were formed, some of them with new T-34 Model 41s like this *rot*. The vehicle in the foreground, number 62, is named 'Pobeda' (Victory); besides the three extra crates of 76.2mm ammunition and unditching beam on the side, it also has a roll of fascines on either side. (Sovfoto)

infantry was far more intimidated by the T-34 than was the Panzerwaffe, as its thick, well-sloped armour was virtually invulnerable to their 3.7cm Pak 36 anti-tank gun, and was highly resistant even to the new 5cm Pak 38 gun. The tank crews that did engage in duels with the T-34s were very impressed. It was invulnerable at most ranges to everything but a lucky shot, and its armament—even the short Makhanov L-11 gun on the Model 1940—was very potent. Its mobility was far superior to the narrow-tracked German vehicles, particularly on soft marshy ground such as in the Pripet region. In the hands of a good crew, it was a weapon to be greatly feared. The *tridsatchetverka* was clearly superior, on paper at least, to any German tank; but the human factor was the key to the equation. After the summer disaster, the Red Army had the near-impossible task of building up a force of combat-experienced tank crews to face the Panzerwaffe.

In view of the horrendous losses in men and equipment, on 15 July *Stavka** began disbanding the remnants of the mechanized corps. By the year's end, their only remains were seven tank divisions, four of which were in the Far East. In their place, tank brigades and independent tank battalions were formed to fight under the control

**Stavka*—Soviet High Command.

of infantry divisions or Front commanders. The first 22 tank brigades began forming in late summer, mainly with new T-34s, KV-1s and T-60 light tanks. This was no mean feat, as in September the tank factories in European Russia had been uprooted and began their long trek into the Urals. The Kharkov Locomotive Works, the primary producer of the T-34, had closed shop before the Germans entered the city, and would not reopen its assembly lines in Nizhni Tagil until December. By now only the Stalingrad Tractor Works (STZ) was still producing the T-34, and even then at a fraction of the June output owing to the disruption of other sub-contracting factories by the German advance. In October, rubber supplies became so critical at STZ that an all-steel road wheel was adopted on the T-34s produced there. This modification was adopted elsewhere.

Among the young brigade commanders who received their first big command in August were a number who would rise to great prominence in the turbulent years to follow. Col. Pavel A.



During the defence of Moscow in 1941, one battalion of T-34 Model 41s, probably of the 11th Tank Brigade, was repainted in winter finish, with an unusual crosshatch banding, in a tank repair shop. These are late production Model 41s with some of the new features, like hammerhead tow hooks and simplified idler wheel, that were standard on the later Model 42. (Sovfoto)

Rotmistrov was given command of the 8th Tank Brigade; and Col. Mikhail Katukov received the 4th Tank Brigade, which was formed at Prudboi on the Don above Stalingrad. On paper, the new brigades were supposed to have 93 tanks. In fact, some had as few as fifteen; Katukov's unit was lucky and received 60. Being near STZ, they received 22 new T-34 Model 41/42s, which served with Capt. Gusiev's 1st Battalion along with seven KV-1s. The 2nd Battalion of Senior Lt. A. Raftopullo had 31 *Betushkas*, mostly BT-7s and BT-8s, but some BT-5s and even a few of the old BT-2 with the small turret and 37mm gun. On 28 September, the brigade was put aboard flatcars and sent to Kubinka outside Moscow to join Gen. D. D. Lelyushenko's 1st Guards Rifle Corps for the defence of the capital. It was a determined and well-trained unit with an energetic and quick-

witted commander. They would soon develop a reputation for both themselves and the T-34.

Driving on Moscow was Guderian's 2nd Panzer Group; Operation '*Taifun*', the capture of Moscow, seemed nearly at hand. Resistance was crumbling, though at Orel and Tula Russian infantry were being stiffened with reinforcements and were fighting doggedly. The thick mud of September was starting to congeal and solidify, and promised a hard and early winter to follow. Temperatures plummeted, and the Panzers started acting capriciously. Oil in the delicate gun sights jelled; other parts froze solid; and the tracks stuck to the ground in the cold autumn evenings. It was an inauspicious start for an army so ill-equipped to handle the cold winter of the endless steppe.

On 4 October, Katukov's 1st Battalion was ordered towards the small town of Mtsensk near Tula. Two patrols were sent out to get a feel for the terrain. The next day, the patrols attacked a German armoured column and wiped it out without loss, claiming eleven tanks and a few trucks and guns. On the night of 6/7 October, the

brigade made its way to the Piervyi Voin woods astride the Orel-Mtsensk highway. Under cover, they watched the approach of a large column of German tanks from the 4th Panzer Division escorting infantry in Hanomag SdKfz 251 half-tracks. As the convoy came within range the order to fire was given, and a salvo ripped it apart. A platoon of three T-34s under Lt. Kukarin left the woods at full speed into the midst of a group of thoroughly confused PzKpfw IIIs. In quick succession, four were hit. The battle raged interminably. Lyubushkin's tank accounted for nine. Kukarin's vehicle suffered some minor damage and ran low on ammunition, so it pulled back into the woods to resupply. On the right, a platoon of four T-34s under Lt. D. Lavrinienko, supported by another group of three KV-1s under Sgt. K. Antonov, joined into the mêlée. Lavrinienko's vehicle hit four; Antonov's claimed seven plus a pair of anti-tank guns he ran over; Kapotov's KV-1 destroyed one, and Polanski got another three along with four motorcycles. The fighting raged until noon, by which time the field was littered with 43 German tanks, sixteen guns and six trucks. The 4th Tank Brigade lost six tanks, of which two were damaged beyond repair and four were towed off for rebuilding. In recalling this encounter, Gen. Heinz Guderian singled it out for the improved tactics of the T-34s, and called it 'very worrying'. He remarked in his memoirs that the battle at Mtsensk had been the first occasion when the vast superiority of the T-34 to the German tanks had become 'plainly apparent'. In the ensuing eight days, Katukov's brigade fought a costly series of delaying actions against Guderian's armour.

The Germans continued their advance, but the 4th Tank Brigade put 133 tanks out of action, two armoured cars, two self-propelled guns, 49 guns, 27 trucks and tractors, and the equivalent of a regiment of infantry. In the process, several of the crews of the brigade became tank aces. D. Lavrinienko (killed at Volokolanski on 18 December 1941) knocked out 52; A. Burda's crews accounted for 30 (though Burda had six tanks shot out from under him in the process); I. Lyubushkin got fifteen, and was among the first to win the coveted award 'Hero of the Soviet Union' (GSS); Capt. A. Samokhin, ten; Lt. Lugovov, thirteen;

Sr. Sgt. P. Molkhanov, seven; and Sr. Lt. Rakhmetov, eleven (posthumous GSS). Not surprisingly, the 4th Tank Brigade was the first Soviet tank unit to be redesignated with the honorific 'Guards' title, and became the 1st Guards Tank Brigade.

The success of the 1st Guards Tank Brigade was attributable both to the improving quality of tank crew training and leadership, and to the technical superiority of the T-34. In the fight at the Piervyi Voin woods, many of the T-34s received numerous hits from 37mm and 50mm fire with no effect. At such close ranges, the T-34's 76mm gun wreaked havoc among the more thinly armoured German tanks. This technical superiority lasted well into 1942, although it was often overcome by superior training and tactics. The Germans did not sit idly by; and by the battle of Kursk, Soviet tankers found the shoe on the other foot.

Operations in 1942

In the spring of 1942, *Stavka* breathed a deep sigh of relief. Catastrophe had been narrowly avoided by the repulse of the German advance on Moscow. Katukov's unit and a few others like it had been an important factor in blunting the armoured edge of the German assault. Nevertheless, of the 890 Soviet tanks in the battles, just under 800 were old T-26s and BTs, and German accounts of waves of T-34s are mistaken. Just as to Allied tankers in Normandy, every German AFV was a 'Tiger', so to the Panzer crews in Russia every Soviet tank was a 'T-34'.

The success of Soviet tank units in the winter of 1941 and the renewed production of the new Ural factories led *Stavka* to consider the re-formation of large tank units. The tank factories, after months of horrible work in the most appalling of conditions, began to reach and exceed their pre-war production levels by the middle of 1942. In April and May eleven new tank corps were formed, and fourteen more were planned. The new corps were nowhere near as large and unwieldy as the pre-war mechanized corps, and were, in fact, divisional sized units. Each new tank corps had a

paper strength of 5,600 men and 168 tanks, divided into three tank and one motor rifle brigade. The early brigades were supposed to have 24 KV-1s, 88 T-34s and 69 T-60s. They were intended to be used as rapid, concentrated strike and exploitation forces. The first four, the 1st, 3rd, 4th and 16th Tank Corps, entered combat for the first time on the Bryansk Front in April 1942. In May 1942 four more, the 12th, 21st, 22nd and 23rd Tank Corps, were committed to the abortive Kharkov offensive. Good equipment does not automatically lead to a potent military force. In spite of the marked superiority of the T-34 over its German opponents, the early tank corps were not very successful. The 23rd Tank Corps was totally wiped out, and many of the rest were gutted by their more experienced opponents.

The inept handling of the tank corps at front and corps level forced Gen. Ya. N. Fedorenko, Chief Marshal of the Tank and Mechanized Forces, to issue a doctrinal order in June 1942 outlining the accepted operational tactics under which the new tank corps were to be employed. Fedorenko was particularly critical of several Front commanders who had divided up corps and sent brigades to support infantry divisions. He reiterated the need to keep the corps together as a cohesive force for use in strategic envelopment, and he stressed the need to follow up the tank corps' penetration of enemy lines with infantry to secure and consolidate the advance, since the tank corps were weak in infantry. The Fedorenko order had little impact on the use of tank corps in strategic offensive operations, because in the summer of 1942 they were deeply entangled in desperate battles to wear down the spectacular German thrust into the Caucasus and towards Stalingrad. The experiences of the summer of 1942 prompted *Stavka* to form new mechanized corps in September 1942. These reversed the organizational emphasis of the tank corps, and comprised three motor rifle brigades and one tank brigade instead of the other way around. As each motor rifle brigade had its own tank regiment, the mechanized corps had more tanks than the tank corps and was the most potent divisional organization of the Red Army in World War II.

Although the STZ tank factory in Stalingrad was inextricably linked with the career of the T-34



in 1942, the T-34 did not play a pivotal rôle in the fighting inside Stalingrad in the autumn of 1942. Once the fighting entered the city itself, few of the 120 tanks involved were T-34s. The brutal business of street-fighting was left to the infantry, and what few tanks were ferried across the Volga to support the rifle companies and shock groups were usually the lighter T-60s and T-70s. These were hopelessly outgunned by the numerous German tanks and StuG IIIs in the city, and many were dug in as static firing points. While von Paulus's Sixth Army impaled itself on the jagged rubble of the burned-out tractor works, the Soviet Army secretly planned a massive counter-offensive to envelope the city and cut off the Wehrmacht's advance into the Caucasus. Five tank corps and one of the new mechanized corps, as well as nearly two dozen independent tank brigades, were poised for Operation 'Uran' (Uranus).

Some of these units had been badly chewed up in the demoralizing rearguard actions of the previous summer, and a few brigades were down to only ten or fifteen tanks. Nevertheless, the tank corps were brought up to strength, and an infusion of veteran crews returning from hospital added sinew and confidence to the fledgling units. More importantly, about two-thirds of the 894



A pair of T-34 Model 41s carry tank infantry forward during a counter-attack in the Sevastopol region in March 1942. (Sovfoto)

The T-34 Described

tanks available were T-34 Model 41s and Model 42s, and there were even some of the brand new Model 43s. In the winter months, the T-34 was far more at home on the snow than the Germans' PzKpfw III and IV or the Rumanians' hopelessly outdated S-IIa (PzKpfw 35t).

At 7.20am on 19 November 1942, artillery of the Don Front received the radio code-word 'Siřen' and within moments the banshee scream of the *Katyusha* rocket batteries announced the opening of 'Uran' all along the fourteen-mile front. Romanenko's 5th Tank Army smashed straight for the heart of the brittle Rumanian Third Army. Gen. Radu's 1st Rumanian Armoured Division made a valiant charge against the wave of T-34s and T-70s, but his S-IIas were mercilessly savaged. In just four days the two Fronts met west of Stalingrad, signalling the first major disaster of the Wehrmacht during the Second World War. It was a stunning tribute to the recuperative powers of the Soviet armoured force.

At this point, it is worth digressing to examine the T-34 in a little more detail.

When sitting inside a T-34/76 one immediately notices how small the crew area is, compared with the German PzKpfw III or the spacious American Sherman. The driver, in the left front of the hull, and the machine gunner/radio operator to his right, had a bit more room to stretch than the gun layer/commander and loader behind them in the two-man turret. The T-34's transmission was located in the rear of the vehicle, so a large assembly did not provide a clumsy separation as it did in most tanks. Even though the front compartment was more spacious than the turret, the driver still had to be rather short to be comfortable—in the neighbourhood of 5ft 5in.! A stocky physique did not hurt, as the vehicle's clutch and brake steering system required a great deal of physical exertion to operate, and it was very tiring after a few miles in rough terrain. When outside of the battle zone, the large front hatch could be left open for better vision; when closed, vision was through two periscopes and a protected slit on the Model 40 and 41, or through two periscopes pro-

tected by armoured flaps on the Model 42 and subsequent types. Instruments were few, and most were located on the shelf to the driver's left, formed where the hull pan sides met the bottom of the superstructure. At the driver's feet beside the clutch and accelerator were large compressed air tanks which were used to start the engine. In the various little cracks and crevices and under his seat the driver stowed personal items, a few tools, forage tools like a small wood axe, and a sealed tin of F-1 fragmentation grenades to ward off German infantry.

The hull machine gunner served as radio operator in the platoon commander's tank, though by the Model 43 nearly all T-34s had radios. Those early vehicles without radios had extra magazine racks for the DT hull machine gun. The original

71-TK radio was fragile and required an experienced operator. The later 9R set was more robust, but still could be temperamental. The operator was also responsible for the internal communications network in the tank, which consisted of a conventional TPU laryngophone unit. The hull machine gun was in a ball-and-socket mount and had a two-power telescope mounted above it. The gunner placed his shoulder against a telescoping shoulder-stock and poked his eye against a padded sight. Firing accurately on the move was virtually impossible. In the event the vehicle had to be abandoned, it was the gunner's duty to remove the DT from the vehicle and bring along the stowed bipod mount, so that the gun could be fired outside the tank. One of the good things about the DT was that it had small circular drum magazines which were reasonably easy to change while the vehicle was in action. There was a certain amount of 'splash' through the ball mount, and eventually, beginning with the Model 42, a mantlet was fitted over the gun barrel.

A column of T-34 Model 41/42s in the marshalling yards of the Stalingrad Tractor Works are inspected before being sent out to the fighting on the outskirts of the city in the summer of 1942. The lead vehicle has the 60mm cast turret, while behind it are vehicles with the modified 45mm welded turret. (Sovfoto)





The crew of a T-34 Model 42 cook soup near their vehicle: a lull in the battles of summer 1942. (Sovfoto)

The vehicle commander sat immediately behind the driver in the left half of the small turret. The position was very cramped, due to the size of the gun and the safety cage built around the breech. The T-34 did not have a turret basket, and the loader and gunner sat on small square mats suspended from the turret ring, with a strip of padding at their backs. The turret floor was in fact made up of thin pressed steel ammunition containers. To prevent the container lids from being continually banged about, a thick neoprene mat was laid over the floor and could be rolled up to get at the rounds. There were nine ready rounds stowed on the hull walls at about knee height, as well as a number of extra magazines for the co-axial DT turret machine gun.

Until the advent of the T-34/85, the commander was also the gun layer. With his left hand he could operate the turret traverse manually, or he could use electric traverse. With his right hand he

could adjust the TMFD gun telescope or the PT-4-7 roof periscope. Firing was usually by means of a foot pedal, though a lever was provided on the breechblock for emergencies. The turret rear bustle was filled with racks of machine gun magazines, though space was left for access to a rear firing port. The commander was close enough to the driver to be able to tap him on the shoulders with his feet to give him steering instructions. At shoulder height on his left was a small glass-protected view slit, and another pistol port with a tampon that could be removed in order to fire at infantry clambering aboard the tank.

The loader sat on the right side, and had a bit more space than the commander since he had no fire controls. He needed every bit of this space to



Gen. Pavel Rotmistrov, standing outside his tank wearing the traditional general's *papakha* cap, watches the operations of his 5th Guards Tank Army in the winter of 1942/43. His tank is a new, whitewashed T-34 Model 43 with a small square tactical marking in red paint. This unit was involved in the fighting around Kharkov in January and February.

bend over to get ammunition, and loading could involve real acrobatics, especially in a moving vehicle. To complicate the matter, he had to slam the rounds home with his left arm. Until the Model 43, the T-34 had a one-piece turret hatch, since the small roof area would not permit two single hatches large enough for a man to squeeze through. Above the loader was a small circular hatch which he used to unfurl small signal flags or to fire a flare pistol. By the Model 43, communications were by means of radio, so these crude methods were no longer needed.

The T-34 was a cramped and uncomfortable vehicle by today's standards. It required a small, but strong and dexterous crew. The Christie independent suspension gave a roller-coaster ride. The engine was shielded by only a thin bulkhead, which made the vehicle very noisy. Fumes from

the guns were extracted by only a single fan, and these factors could lead to the quick onset of motion and noise exhaustion in combat.

The most serious defect of the T-34 was the two-man turret. It was too small to allow the gun to be served efficiently and quickly; and more importantly, the commander was obliged to concentrate his efforts on laying and firing the main gun instead of directing the actions of his crew. This gave the German tanks with a three-man turret a decided tactical advantage. Vision devices were marginal at best, until the addition of a cupola for the commander on later production Model 43s. (Incidentally, the hoary old tale of German anti-tank teams being able to lodge grenade bundles and mines under the rear turret overhang is false. The authors can confirm the difficulty of sticking even a couple of fingers under the overhang, let alone a mine.)

In spite of these shortcomings, the T-34 had some less obvious virtues. Its diesel fuel was far less explosive than the petrol used in German tank engines, and the T-34 was thus less liable to 'brew up' than German tanks. Its designers were far



A column of T-34 Model 42s of the type produced at Zavod No. 112, and some T-34 Model 43s are handed over to a brigade in May 1943. The vehicles were paid for by subscriptions of Estonian workers in the USSR, and the inscriptions read 'For Soviet Estonia' in Russian with 'Long Live Estonia' in Estonian below. (Sovfoto)

more aware of cold weather requirements than the German engineers, and as a result its lubricants and engine caused far fewer problems in frigid temperatures. The T-34's wide track gave excellent flotation on snow and other poor ground, and gave excellent traction with the special ice cleats bolted on.

The **T-34 Model 1940** was produced with both the 45mm-thick welded turret and the Nisenko-Buslov 52mm cast turret. Its primary characteristic was the short-barrelled Machanov L-11 gun. It was referred to by the Germans as the T-34/76A. The **Model 1941** originally entered service as a platoon commander's vehicle, equipped with the more potent Grabin F-34 gun. It soon became the standard production model, and also appeared with both the welded and cast turret.

The **T-34 Model 42** was a simplified version developed to cut down on production time and save material. Although some early machines used the old 45mm welded turret, most were fitted with an improved cast turret 60mm thick. The characteristic features of the Model 42 are the new

hull front with simplified driver's hatch and hammerhead tow-hooks, and the new rear plate with a circular instead of rectangular transmission access panel. The later production vehicles from Zavod No. 112 Krasnoye Sormovo had box-style fuel containers at the rear, and some final production machines even had the cylindrical fuel cans. Details on these machines varied from factory to factory, and STZ produced a hybrid Model 41/42 which incorporated some but not all of the new modifications. The Germans did not distinguish between the Model 41 and Model 42, but referred to both as the T-34/76B.

In the late summer and early autumn of 1942, the assembly halls began to turn out the first examples of the **T-34 Model 43**. These were the same as the late Model 42s except that they were fitted with a new, larger hexagonal turret. This

turret gave the crew more room to move about and had two roof hatches. In the early spring of 1943, a modernized version was introduced with a cupola for the commander. This was added after troop complaints about the inadequacy of the vision devices on the earlier production models of the Model 43. At the same time, pistol ports were added. The Model 1943 remained in production until the spring of 1945, and was the most widely produced of the 76mm gun versions of the T-34. The early type without commander's cupola is occasionally referred to as Model 42/43, and was called the T-34/76C by the Germans. It first saw action during Operation 'Uran'.

A T-34 Model 43 and Lend-Lease M-3A1 (Diesel) light tank take a breather on Lenin Street in Byelgorod in March 1943, after the hard fighting around Kharkov. These tanks are probably of Rotmistrov's 5th Guards Tank Army. (Sovfoto)

The German Response: 1943

The Germans did not sit idly by and let the T-34 run amok. The PzKpfw III and PzKpfw IV were rearmed and up-armoured to restore the balance, though they remained inferior in mobility to the T-34. 'T-34 panic' had been so great in the winter of 1941 that some German officers had seriously suggested that German industry simply start manufacturing exact copies. National pride dictated against the adoption of a product of 'sub-humans'; and in any event, German industry did not have the technology to produce the aluminium crankcase used in the T-34's V-2 diesel engine. Two new tank designs were initiated to meet the threat of the T-34: the PzKpfw V Panther medium tank, which entered service in the summer of 1943 and the PzKpfw VI Tiger heavy tank, which entered service in the winter of 1942-43.





The 112th Tank Brigade of the 6th Tank Corps is presented with new T-34 Model 43 tanks on 12 January 1943 from donations collected in the Mongolian SSR. The inscriptions on the turret are in red and the bottom line reads 'Revolutionary Mongolia'. (Sovfoto)

The Panther, although called a medium, was nearly twice as heavy as a T-34, and about equal in size and weight to the later Soviet IS-2 heavy tank.

The Tiger mounted the vaunted 88mm gun, and its armour was proof against the T-34's 76mm gun except at close ranges or from the side and rear. It was first committed to action on the Eastern Front in August 1942, when sPzAbt 502 (*schwere Panzer Abteilung* = Heavy Tank Bn.) was sent to the Leningrad area. It saw very little fighting until January 1943, when the Russians launched Operation 'Iskra' (Spark), to link up encircled Leningrad with the Volkhov Front to the east below the shores of Lake Ladoga. Heavy Battalion 502 savaged the Soviet 61st Independent Tank Brigade, which was equipped mostly with T-60 light tanks armed with a largely useless 20mm gun. In a single engagement on 13 January, four Tigers of 1st Company claimed twelve T-34s, though in fact these were T-60s. During the fierce fighting around the key town of Rabochii

Poselek No. 5, a column of two Tigers and one PzKpfw IIIH under Sgt. Johannes Bolter was on patrol when, in the late afternoon, they ran into a scouting party of three T-60s from the 61st Independent Tank Brigade and knocked them out in quick succession. As luck would have it, the burning wrecks illuminated the German tanks and a nearby Russian anti-tank gun slammed two rounds into the engine compartment of Bolter's Tiger. Soviet infantry in the area reported the incident to divisional headquarters, and mentioned that one of the tanks knocked out was much larger than the other and had a very long gun.

At the time, Gen. Georgi Zhukov was visiting the Volkhov Front commander, Gen. Meretskov, as a representative of *Stavka* during the 'Iskra' operation, and he quickly realized the signifi-

cance of the report. Zhukov ordered the vehicle captured at all cost. The assignment was given to eighteen men under Lt. Kosarev of the 86th Independent Tank Regiment. Kosarev's T-34s were fitted with extra tow-cables, and set out on the night of 17 January. The Tiger was in no man's land, and the Germans had the area under observation. As Kosarev's group approached, the area was illuminated with a flare and the tanks were lashed first by machine gun fire, and then by mortars and artillery. Some of the tanks were hit. Kosarev arrived first and quickly jumped out. He had hoped to drive the tank back, but one look at the engine convinced him otherwise. Cables were attached, and the wreck was towed away.

A column of T-34 Model 43s moves to the front in the summer of 1943 at the time of the Kursk battles. The lead tank is commanded by Lt. Dmitri Zernov, and the inscription reads 'From the Trade Union of Co-operative Centres'. (Sovfoto)

Zhukhov immediately ordered it to Moscow for inspection. Besides the Abteilung's elephant insignia, it carried the tactical number '01' and the factory serial 250 003.

The captured Tiger was carefully examined. It did not precipitate an immediate response among Soviet engineers assigned to Morozov's GKB-T-34 design bureau at Nizhni Tagil, since Kotin's GKB-2 bureau at Chelyabinsk was developing the potent new KV-85 to handle the new German heavy tanks. The decision against up-arming the T-34 at this stage was due both to the adequacy of the T-34 in handling the majority of existing German tanks, and the desire of the NKTP industry representatives not to interrupt the steady flow of T-34s from the Urals for the sake of a heavily revised new version. The Red Army was crying out for more T-34s for the forthcoming summer's offensives, and no stumbling blocks





A T-34 Model 43 of the Finnish 1st Armoured Division sits after a parade in Aanislinna in October 1942. The Finnish Army used mainly Russian manufactured tanks which were either captured in combat or purchased from the Germans. (Klaus Niska via Esa Muikku)

were to be put in the way of maximum production.

The central encounter of the summer loomed up in the area around Kursk-Orel. A deep salient jutted out into German lines, and in order to retain strategic initiative in the East Hitler was determined to shatter the Red Army units which held it. Soviet intelligence was aware of these plans in detail, and the Red Army responded by amassing a deeply layered belt of infantry and artillery at the northern and southern bases of the salient to absorb the initial German punch. Once the Germans were worn down, huge reserves of tanks would pour out into a general counter-offensive. The northern half of the salient was controlled by the Central Front while the southern sector was handled by the staff of the Voronezh Front. Inside the salient, and in the reserves to the east of it, were about 5,000 armoured vehicles, which was over half the armoured strength of the Red Army. In the flanking Steppe and Bryansk Fronts there were another 2,500, so that in this central region the Red Army had over 78 per cent of its tanks and self-propelled guns concentrated to confront Operation 'Zitadelle'. The Germans

mustered about 2,700 tanks, which constituted 61 per cent of the Panzerwaffe on the Eastern Front. The Soviets had a very decided quantitative edge over the Germans, though the Germans held a qualitative edge. About a third of the Russian force was made up of the light T-70s and older T-60s, and there were only small numbers of KV-1s. Kursk would be the first major battle in which sizeable numbers of Tigers, Panthers and Ferdinands would be employed.

The experiences of the previous winter around Stalingrad had given the Red Army new confidence in handling large armoured formations. Just before Kursk, the Tank Armies were reformed; and for the battle, five Tank Armies with a strength of fifteen tank and mechanized corps were ready for action. The more mature and professional attitude of the Red Army in 1943 was nicely summed up by Nikita Khrushchev, at the



During the battle of Kursk the Russians dug in a portion of their tank strength, like this STZ T-34 Model 41/42, while others, like the T-34 Model 43 in the background, were used in mobile counter-attacks.

A column of T-34 Model 43s and SU-85s moves through the town of Mogilev on the way to Minsk during Operation 'Bagration'. The motor column consists of Lend-Lease US Dodge $\frac{1}{2}$ -ton trucks. (Sovfoto)



time chief political officer of the Military Council of the Voronezh Front. He lectured the officers:

'You've really got to take care of these young people more efficiently. None of that stupid, stale, vague propaganda . . . Don't waste time making them learn slogans. But make sure that every single one of them knows the vulnerable spots on the new German Tiger tanks, just like we once knew the Lord's Prayer.'

The Germans struck on 5 July 1943 and made rapid but costly inroads on the northern flank of the salient. Rokossovskii's Central Front had the 2nd Tank Army with the 16th Tank Corps around Samodurovka in the centre, the 3rd Tank Corps around Zolomukhina on the right flank and the 19th Tank Corps on its own on the left. The first day's attack penetrated six to eight kilometres, but was met the following morning by a vigorous attack by Gen. Grigoyev's 16th Tank Corps, which regained perhaps a quarter of this ground. A battle developed between about 100 Soviet tanks of the 16th Tank Corps and 107th and 164th Tank



Brigades and 200 German tanks. Col. N. Telyakov's 107th Tank Brigade claimed 30 tanks, four of them Tigers, but their own losses were serious. The counter-attack did not live up to expectations, but seriously diminished the threat in that sector. The tank units withdrew to the second defence line and continued to launch local sallies. On 7 July, the Germans again attacked in force with nearly 300 tanks against the 16th and 19th Tank Corps. The following day, 80 tanks struck Pon'ri and were met by T-34s of the 51st and 103rd Tank Brigades of the 3rd Tank Corps and were thrown back. This attack, which involved the use of the massive Ferdinand self-propelled guns of Heavy Tank Destroyer Bns. 653 and 654, was the high-water mark of the attacks on the northern flank of the Kursk salient. After a week of tough fighting the German units were emaciated, and poorly prepared to handle the flood of armour that would soon cascade out of the Bryansk Front towards Orel in their rear.

Col. Shurenkov's 5th Guards Tank Brigade attacks north-west of Novorossisk in September 1943. The tanks are a T-34 Model 41 on the right and a T-34 Model 43 on the left.

The German assault in the south had better results. The 48th Panzer Korps smashed into the Russian infantry divisions around B'kovki. The little 245th Tank Regiment claimed 42 enemy tanks in the fighting, but was soon overrun itself. Counter-attacks were launched by the 230th Tank Regiment and the 96th Tank Regiment, and the latter claimed seventeen enemy tanks before being pushed aside. The following day, Gen. N. E. Vatutin committed Gen. M. E. Katukov's 1st Tank Army to the fray. Katukov's Army contained the 6th and 31st Tank Corps and the 3rd Mechanized Corps. The fighting was incredibly intense, with as many as 400 tanks milling about and blasting away at each other from very short ranges. Col. Bedemichev's 22nd Tank Brigade of the 31st Tank Corps had its perimeter between



An OT-34 flame-throwing tank on the Ukrainian Front in the late summer of 1943 carries the number D-50 and the slogan 'From the Tartar A.S.S.R. to the Front'. The OT-34 can be distinguished by the stubby flame-thrower mount in front, or in the case of a rear photo like this, from the radio pot on the turret rear. (National Archives)

Tank number 116 'Leningradyets' of the 30th Guards Tank Brigade was one of the first into Krasnoye Selo outside Leningrad in January 1944. This unit was formerly the 61st Tank Brigade, and made the transition from T-60s to T-34 Model 43s in the summer of 1943. See cover illustration.



Zavidovka and Shepelevka assaulted four times on 6 July by forces of up to 70 Tigers and Panthers. Nor was there any respite on 7 July. The 124th Tank Battalion of the 3rd Tank Corps was repeatedly sent on local counter-attacks and claimed 21 enemy tanks including six Tigers; but it was being worn thin, and the men were exhausted. Maj. S. Bobchenko's 2nd Tank Battalion, 1st Guards Tank Brigade at Yakovlev was hit by a wave of 70 enemy tanks. The crews had been told to wait until the Tigers closed to at least 900 metres, at which point they opened fire. The Germans pressed in, but eventually retreated. A T-34 commanded by Lt. V. S. Shalandrov was credited with two Tigers and a PzKpfw IV; he received the GSS.

On 9 July, the threat towards Oboyan seemed serious and Kravchenko's 5th Guards Tank Corps was sent to help the 1st Tank Army. Intense fighting continued, with the 48th Panzer Korps and the 2nd SS Panzer Korps forcing back the Soviet tank brigades and infantry kilometre by bloody kilometre. The Luftwaffe's Hs129 and

Ju87G Stuka tank-busters roamed the area, and caused serious casualties on many occasions. But for every Russian tank lost to the air attacks, the Germans lost tanks to the minefields and to the determined work of Russian anti-tank rifle teams.

The 1st Tank Army brought elements of the 3rd Mechanized Corps and the 31st Tank Corps from the second echelon, which helped stabilize the front against the 48th Panzer Korps. The Russians developed tactics of digging in a proportion of their T-34s to take advantage of defilade fire while parrying the Germans' thrusts with forays by other T-34s from immediately behind the first line of attack. On 10 July, the 'Totenkopf' Division of the 2nd SS Panzer Korps succeeded in forcing a bridgehead over the River Psel. The 48th Panzer Korps seemed to be checked at Novoselovka by the 5th Guards Tank Corps, and the main threat was seen as coming from the three élite divisions of the 2nd SS Panzer Korps. On the right was 'Totenkopf', in the centre was the 'Leibstandarte Adolf Hitler', and to the left was 'Das Reich'. As the route through Oboyan had been denied them, they pressed on towards Prokhorovka. Gen. Pavel Rotmistrov's 5th Guards Tank Army had been brought 360km from the reserves for a major

counter-offensive towards Yakovlev, but the dangerous German drive of 11 July gave the Russians no choice but to commit his tanks towards Prokhorovka to smash the threat.

Rotmistrov's 5th Guards Tank Army consisted of the 18th and 29th Tank Corps and the 5th Guards Mechanized Corps. The army had a strength of a little over 800 tanks. These consisted of 501 brand new T-34 Model 1943s, and 264 light T-70s. The heavy tank regiment attached to the army had only 35 British-supplied Churchill tanks, which the Russian crews viewed very disparagingly due to their slow speed and poor firepower. Each of the corps had a regiment of SU-76 Suka self-propelled guns, but none of the SU-152. On either side of the 5th Guards Tank Army was the 2nd Guards Tank Corps and the 2nd Tank Corps. The 5th Guards Tank Army set off for Prokhorovka in the early morning of 12 July with the 18th Tank Corps on the right flank, the 29th Tank Corps in the centre and the 2nd Guards Tank Corps on the left. 5th Guards Mechanized

continued on page 26

A late production T-34 Model 43, with commander's cupola, belonging to the 109th Tank Brigade of the 16th Tank Corps, knocked out in the fighting of winter 1943-44.



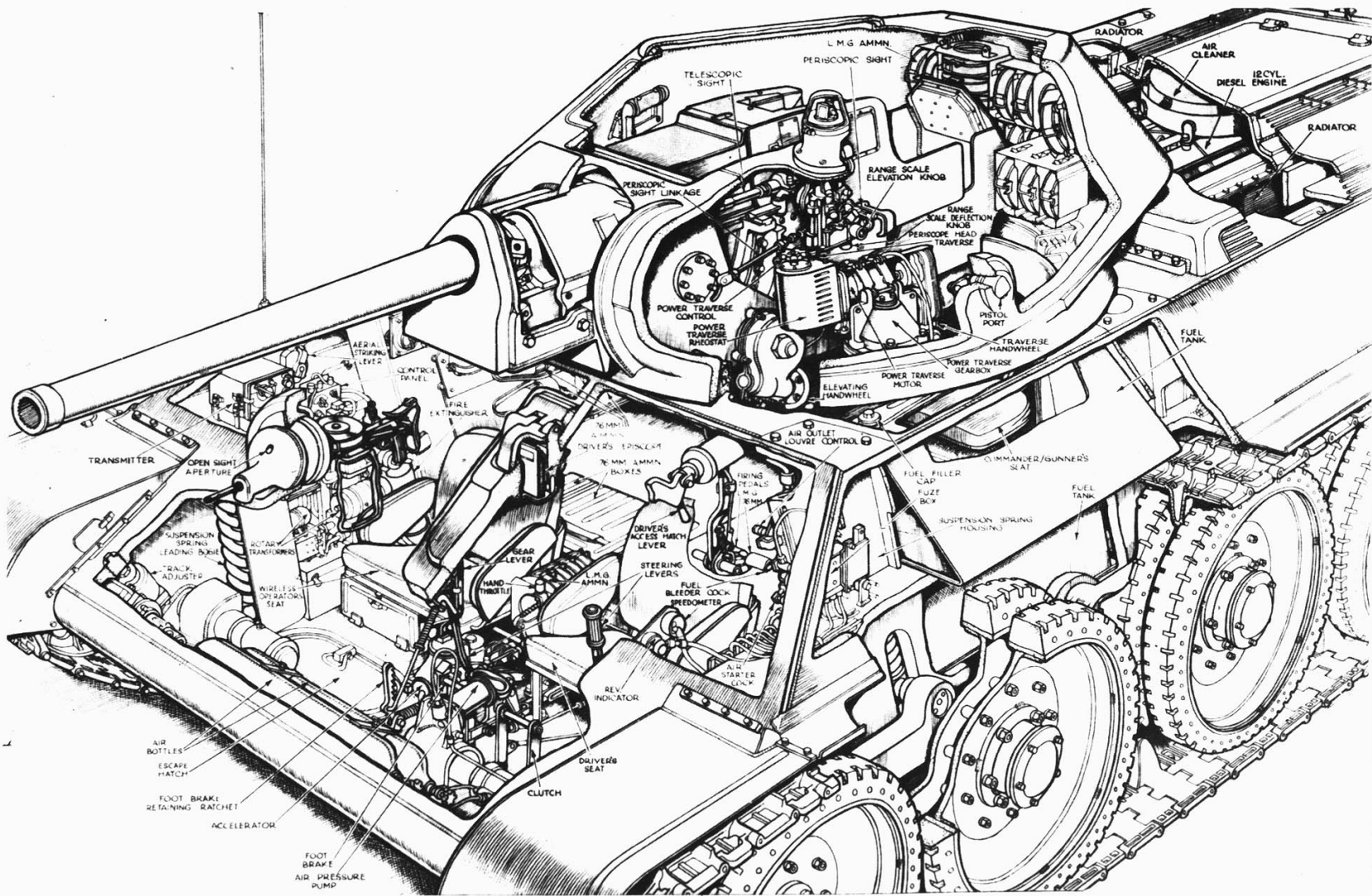

Cutaway of T-34 Model 1942 — cf. Plates F and G. (RAC Tank Museum)

Key, Plate F: T-34 Model 42 hull positions.

See also cutaway on page 24:

- 1 Hull gunner/radio operator's seat
- 2 Belly escape hatch
- 3 Magazine stowage for DT machine gun—single row of four drums
- 4 Gear shift
- 5 Hand throttle
- 6 Foot throttle pedal
- 7 Driver's seat
- 8 Foot brake
- 9 Foot brake locking ratchet
- 10 Compressed air cylinders
- 11 Manual air pump
- 12 Clutch pedal
- 13 Grease gun
- 14 Air distribution control valve
- 15 Electrical distributor panel. Invisible from this angle, but mounted on the side wall just ahead of the top corner of this panel was the starter button.
- 16 Driver's hatch counter-weight assembly
- 17 Tachometer (left) and speedometer (right)
- 18 Instrument panel
- 19 Steering levers
- 20 Intercom
- 21 Ball-mounted DT machine gun with telescoped butt, drum magazine, and empty cartridge bag
- 22 Type 9R radio equipment
- 23 Front suspension housing. The photo from which we take the radio set shows a cut-out in this housing, revealing the spring inside, but this was not normal.

In the **T-34/85** the area between the first and second suspension housings on the right of the hull gunner's position was used for extra ammunition stowage, since the radio equipment had moved to the left wall of the turret. On the deck beneath the ball mounting was a two-row rack for DT ammunition, 2 × 5 drums stowed on edge. A rack holding a single vertical stack of seven drums was

fixed to the right side wall butted against the rear and top of the first suspension housing. Aft of this was upright stowage, in clips, for two rounds of 85mm ammunition.

Key, Plate G: T-34/85 turret:

- 1 85mm gun with deflector shield
- 2 Ventilator
- 3 Main turret light
- 4 Co-axial DT machine gun
- 5 Periscopes
- 6 DT drum stowage
- 7 4 × 85mm rounds
- 8 Turret traverse hand lock
- 9 Loader's seat, slung from gun and turret ring
- 10 Gunner's seat, fixed to gun
- 11 Gun elevating wheel
- 12 Power traverse mechanism
- 13 Commander's tip-up seat, fixed to turret ring
- 14 Shaded light over calculating table on top of traverse mechanism
- 15 Pistol port, tampon in place (note second port opposite, forward of ammunition stowage)
- 16 Radio equipment
- 17 Electrical distributor box
- 18 Telescope sight
- 19 Telescope sight illumination

In the **T-34/76** the rear turret bustle was filled with DT drum racks—see cutaway on page 24. In the **T-34/85** the bustle housed main ammunition stowage; a rack held four layers of four rounds each, heads to right as viewed from inside turret, with a plywood bulkhead coming forward from the rear turret wall to shield the left-hand end of the rack. The heads of the single set of four rounds on the right rear side wall, no. 7 above, fitted into the space between this plywood shield and the turret side wall. Apart from the right side of the hull gunner's position, and small details of the belly hatch clipping, etc., the hull positions of the Model 42 and the T-34/85 were largely identical.



The Wehrmacht used a number of captured T-34s, like this T-34 Model 43 somewhere in Rumania in the summer of 1944. The vehicle is heavily marked and repainted in German three-tone camouflage. The addition of side skirts over the suspension is noteworthy. (National Archives)

Corps and the 2nd Tank Corps remained in the rear. The actual front echelons that would be involved in the fighting amounted to about 500 tanks, of which 200 were T-70s and the remainder T-34s.

As it happened, Hausser's 2nd SS Panzer Korps was intent on launching its final drive on the same morning and in the same area that Rotmistrov's tanks were approaching. Hausser's forces had about 700 tanks in the fore and reserves, of which about 100 were the new heavy types. Hausser had a distinct technical advantage as the battle began, while Rotmistrov had potential quantitative advantage with reserves in the second echelon of attack. Reconnaissance on both sides was poor due to the chaotic situation in the front lines. By 10.00am both sides had madly raced into each other's clutches and a vicious, close-range mêlée was developing.

On realizing that they had met the Germans head-on, the Russian units lost no opportunity to approach as close as possible. In the opening stages of the Kursk battle, Russian tank units had taken stiff losses by allowing the Germans to slug it out at long ranges. By attacking at close range, the Russian crews eliminated the Germans' long range edge; at point-blank range of 500-600 metres, the Tigers and Panthers were vulnerable to the T-34's 76mm gun, especially on the side. By sunset, the fields for miles around glowed with

the smouldering carcasses of hundreds of tanks. The Germans launched a last counter-attack in the early evening with about 200 tanks, but were thrown back. The next morning, the Russians were reinforced and began their counter-attacks.

The 29th Tank Corps had lost 60 per cent of its tanks destroyed or damaged and the 18th Tank Corps lost 30 per cent. During the battle around Prokhorovka both sides suffered losses of about 300 tanks each, though both sides were able to recover and repair a proportion of them. This battle has justly been called the death ride of the Panzerwaffe. It marked the turning point in the Kursk battle, and signalled the final loss of German strategic initiative in the East. The tide of war had inexorably swung in favour of the Red Army. While both sides had suffered appalling losses, these could more readily be absorbed by the Red Army than by the Wehrmacht. The news of the Allied invasion of Sicily provided the Germans with a face-saving excuse to call off the offensive. By 23 July, the Russians had recovered most of the lost territory in the Kursk salient; and after a week-long breather to regroup, they lashed out with a massive counter-offensive which propelled them into Kharkov and Orel.

The victory at Kursk was the turning point of the European War, and much of the credit was owed to the tank crews who blunted Hausser's dangerous advance. While historians have often



Tank infantry armed with PPSH sub-machine guns stand by their T-34/85 Model 43 during presentation ceremonies with Patriarch Sergei of the Russian Orthodox Church in March 1944. These are the early T-34/85s armed with the D-5T gun, as is evident from their heavy mantlets. The turret slogan is 'Dmitri Donskoi'. (Sovfoto)



A T-34/85 of the 2nd Guards Tank Corps enters the Byelorussian capital of Minsk in July 1944. The corps' white arrow insignia is barely evident under the legs of one of the crewmen. (Sovfoto)

belittled the Soviet successes as victories of sheer mass against smaller and more skilled German units, it should not be forgotten that at Prokhorovka Russian numerical superiority was illusory, and in fact this was true in many other key stages of the Kursk battle. It was not until the counter-offensive got into full swing that the massive reserves of armour would be let loose. The success at Kursk rested upon the improved training of the Russian tank crews as compared with the two previous dismal summers, and the more mature handling of the tank brigades by corps and front staffs.

Following the Kursk victory, 180 of the men who made it possible were awarded the Hero of the Soviet Union decoration. The GSS, which had been given out so sparingly in the previous two years of war, was now more lavishly distributed. Many survivors of the horrible summer of 1941, of the battles of Brody-Dubno, of the Berezina River, and of the first and second battles of Kharkov, could think of many a brave tanker whose heroism had gone unrecognized in those years of despair and national agony. The summer of 1943 was one of relief and great joy, and the flow of medals marked it.

Our colour plates reflect these trends. As more medals were given out, more attention was focused on the crewmen. Unit élan led to the more

widespread use of brigade insignia, and markings proliferated. Of the 10,000 GSS decorations issued during the war, 1,140 were won by tankers. Sixteen men won the award twice, among them Gen. A. G. Kravchenko of the 5th Guards Tank Corps, whose command tank during the Kursk battle is shown as Plate B1 in our colour pages. During the war 73 women soldiers won the decoration, one of these a tanker, Sgt. Maria Vasileva Oktyabr'skaya.

During the later years of the war, about a tenth of the Red Army was made up of women. Revolutionary blandishments about equality aside, the real reason for the lifting of this traditional social barrier was the desperate need for manpower. In 1941 alone, the Wehrmacht had captured over three million Russian soldiers, of whom few would survive starvation, disease and extermination in German camps. It was a very brutal conflict, and twelve million Soviet soldiers would die in the four years of war. In the middle of the war there was a Russian saying to the effect that of 100 men to go to the front, four would return alive. At first, women were accepted for the less arduous non-combatant tasks, especially as staff aids, com-



Gen. Heinz Guderian inspects a T-34/85 of the 2nd Guards Tank Corps knocked out in East Prussia in October 1944. The MDSH smoke canisters have fallen off the rear plate and are behind the vehicle.

munication troops and as nurses. As the war dragged on, nurses became front line medics; and others became snipers, mortar crewmen, fighter and bomber pilots and eventually tankers. They began to enter the ranks of tank units in small numbers in 1943, usually as driver/mechanics.

At the time, the pool of mechanically adept young men had been drained. The two previous summers' campaigns had sacrificed many of the soldiers who in peacetime had been tractor and truck drivers. The work crews in the Ural tank factories were 50 per cent women at the time, and there was a trained pool of young girls who had served with mechanic squads, test driving the tanks around the factory tracks or driving them to railway sidings to send them to the front. This was more training than most of the young male driver recruits would ever get before being sent into combat. The women, often only teenagers, were siphoned off in small numbers in 1944 and 1945, and by the time of the Berlin operation some had become tank commanders.

Maria Oktyabr'skaya was born in 1902 in the Crimea to a peasant family, and after completing schooling worked in a canning factory. She married a young officer cadet and became a telephone operator. Her husband was killed in 1941 while serving as a commissar with an artillery unit. She was badly shaken and embittered by his loss. She began to pool her savings to subscribe for the purchase of a tank, which was a popular patriotic gesture at the time. While working in an arma-

ment factory in Siberia, she was accepted into the Army and trained as a tank mechanic. In October 1943 she received the rank of sergeant, and was assigned to the crew of a platoon commander, Lt. Chebotko of a Guards tank brigade. A ceremony was held that month when her crew was presented its new tank, a T-34 Model 43, purchased with contributions from the Sverdlovsk region, and prominently marked with the name '*Boyevaya Podruga*'.*

The crew first saw action at Novoye Selo in the Vitebsk area in November, where Oktyabr'skaya distinguished herself by knocking out an anti-tank gun by running it over. On 17 January 1944, in the area of Krnki Lioznenski, the tank was disabled by a mine and she was severely wounded, dying in March. She was honoured with a posthumous Heroine of the Soviet Union award, and her memory was fostered. Publicity of her exploits led to public contributions for new tanks, including a second T-34 '*Boyevaya Podruga*', which served at Minsk, and an IS-2 which served at Berlin.

The custom of subscribing for weapons began in 1941 as a patriotic gesture, and by the war's end some 5.8 billion roubles had been donated for tanks, providing enough funds for the manufacture of 30,522 armoured vehicles. Generally, the practice was for a collective farm (*Kolkhoz*), school, or factory to pool its savings and 'purchase' an entire battalion or brigade of tanks. In some cases, a formal presentation ceremony was held and the subscribers' names would be painted on the tank turrets. For example, the collective farms of the Tambov region contributed forty thousand roubles towards the manufacture of a brigade of T-34s. These were presented to the 133rd Tank Brigade commanded by Col. N. Bubnov and the turrets had the name '*Tambovski Kolkhoznik*' painted on the sides in red. Not all subscription vehicles had these markings so conspicuously painted, and in most cases they were limited to a small plaque attached inside the tank.

In some cases, regions purchased tanks specifically for local boys. The *syem* (council) of a collective in Voroshilovgrad subscribed to a T-34/85 for Lt. Ivan Kisenko, who had been adopted as a

*This name does not translate easily into English. Podruga is the feminine form of the Russian word for friend, but the English phrase 'Fighting Friend' does not convey the sense of the expression.



The tank of Lt. Aleksander Oskin enters the Polish village of Rebow shortly after Oskin's encounter with the *Königstigers* at Ogledow in August 1944. Oskin is the smiling fellow with his hand on the driver's hatch (Sovfoto)

young child by a local farmer, Yakov Shulgi, and had grown up in the area. On its side was painted 'From father Shulgi to my son Kisenko' along with the rampant bear insignia of the 36th Tank Brigade (see Plate C3). The Russian Orthodox Church sold off many of its precious gold sacramental vessels and paintings to pay for an independent flame-thrower tank brigade serving with the 1st Guards Tank Army. On the turret sides was painted the name of the legendary Russian prince Dmitri Donskoi.



Two of the *Königstigers* knocked out by Oskin blew up, and the third, a PzBefWg command tank, number 502, was sent back to Moscow. Barely legible on the side skirts is a chalked inscription crediting Oskin's unit with the capture.

At several post-operational meetings, tank officers bitterly questioned why a new version with a 'longer arm' was not ready. The winter offensive wrenched much of European Russia out of German hands, but it would not be until early spring 1944 that the designers' response would be forthcoming.

Since summer 1943 Morozov's design teams, in conjunction with engineers at the Krasnoye Sormovo Plant and the artillery bureaux of Grabin and Petrov, had been developing a new version of the *tridsatchetverka* armed with a potent new 85mm gun. Grabin's ZIS S-53 gun was selected, but owing to teething problems in production, the first of the new T-34/85s manufactured in December 1943 were armed with the runner-up, the D-5T gun from the Petrov bureau. The D-5T was the same gun used in the SU-85 and the KV-85. The T-34/85 first saw combat in March and April 1944, and crews were unanimous in their praise of the new vehicle. The T-34/85 marked the culmination of the *tridsatchetverka* family. While it was a bit more sluggish than the T-34 Model 43, it embodied all the mechanical advances of the previous series and housed a far more potent anti-tank weapon. Equally important, the new tank had a three-man turret which was better suited to the more sophisticated tactics and better trained crews of the 1944 period. The commander could now focus on his main rôle of directing the vehicle in combat, and by now all vehicles were radio-equipped.

1944: New Gun, New Victories

While *Stavka* was reasonably happy with the performance of the tank armies at Kursk, in the following offensives it became immediately apparent that they had a lot to learn about strategic advances. The Kursk-Orel battle also strongly impressed on Soviet officers the need to up-arm the T-34 as soon as possible. For nearly two years, the T-34 had reigned supreme; but at its greatest victory, it was shown wanting. The Red Army had a Tiger since January 1943, but a suitable opponent for it was not immediately available.



A T-34 Model 43 of the Polish 2 *pulk czołgow*, 1 *brigada pancerna*, taken at the time of fighting around the Studzianki folwark in August 1944. The driver has a typical Russian tank crewman's padded helmet, while the turret crew is wearing the Polish *rogatywka* field cap.

The T-34/85 did not enter service in time to take part in the great encirclement of the Korsun pocket, though this operation did mark the debut of its new stablemate, the IS-2 heavy tank. The IS-2 was about the same size and weight as the German Panther, and carried a 122mm gun which could disembowel any existing tank. It generally equipped independent tank regiments, while the T-34/85 became the new staple of the tank brigades.

With hardly a breather after their hard-won crossing of the Dniepr and the advances into Byelorussia, *Stavka* planned another major offensive. While confusing the Wehrmacht into ex-

A column of T-34 Model 42 and Model 43s lead by a GAZ-67B jeep are called to a halt during the drive into the Carpathian Mountains in eastern Slovakia in the summer of 1944. (Sovfoto)



pecting another large offensive in the south around the Ukraine, the Baltic and Byelorussian Fronts were secretly built up with much of the new T-34/85 production opposite the so-called 'Byelorussian Balcony'. Between 23 and 28 June, Operation '*Bagrati*on' kicked off on four fronts, and the hopelessly harried Army Group Centre all but disintegrated. The Red Army's advance displayed an elegance and precision of execution that had not previously been seen, and the ensuing advance was matched in speed only by the German advance of 1941.

Among the units taking part in '*Bagrati*on' was the 2nd Guards Tank Corps. It had originally fought at Stalingrad as the 24th Tank Corps, and its success in the vital capture of the Tatzinsk airport earned it the Guards designation. Most of its crews were veterans, but there were newcomers. Lt. Dmitri Frolikov was no greenhorn, but his route into the corps' 4th Guards Tank Brigade was more circuitous than most. Frolikov had enlisted in the Soviet Navy in 1939, saw sea duty in the Russo-Finnish war, and at the war's outbreak in 1941 was in command of a G-5 motor torpedo boat of the Baltic Fleet. Torpedo boat duty was tough and hazardous, and Frolikov was wounded on three occasions, always returning to his boat shortly after. On the fourth such occasion, he was so badly wounded that the doctors declared him unfit for any further military service. Frolikov did not find this premature retirement to his liking, and began visiting a tank training school near the hospital where he was recovering. After making a general nuisance of himself with constant letters to the base officers, the school waived the medical decision and allowed him to study as an officer candidate. In 1944, he was assigned as a tank platoon commander.

On the first day of the offensive, Frolikov's three tanks were sent to try to cut the Minsk-Moscow highway behind the German lines near Orsha. Under the cover of woods, they approached the road and spotted a long German motorized column moving forward towards the main body of the 2nd Guards Tank Corps. At the front of the column were three tanks, and two more followed up at the rear. Frolikov's tank took on the forward elements, while he sent the other two tanks through the woods to wipe out the rearguard.

Frolikov's tank 'Chervonyets' (see Plate C2) raced forward at full speed, drawing inaccurate fire from the leading German tanks. Frolikov halted his tank, and his gun crew quickly knocked out the two leading tanks. Simultaneously the other two T-34s knocked out the last two Panzers, and then ran amok amongst the trucks and half-tracks. On 24 July, Frolikov was once again assigned advance duty; his T-34s were sent to cut a river ford past Orsha where German vehicles were retreating. The fighting at the ford was at close range and was intense. At one point, 'Chervonyets' and a German tank ran into each other. Frolikov and his men destroyed two tanks, two self-propelled guns and several dozen German trucks that had been caught in mid-stream. His skill and determination led Col. O. A. Losik, the brigade commander, to recommend him for the GSS. On 2 July, when the corps reached the suburbs of the Byelorussian capital of Minsk, the corps commander assigned the 4th Guards Tank Brigade the honour of being the first into the city. Losik chose his best crews to fight their way into the city centre, and Frolikov's crew was the first to succeed on 3 July 1944.

The destruction of the German Army Group Centre was an unmitigated disaster for the Wehrmacht, of the same order as the destruction of the Normandy Army at Falaise. The Red Army also advanced simultaneously along the southern front through the Ukraine, and on 22 July 1944 finally reached the outskirts of Lvov. Among the tank units breaking into the suburbs was the 10th Guards Tank Corps of Gen. E. E. Belov. The corps' 63rd Guards Tank Brigade was assigned to break into the centre. Its commander, Col. M. G. Fomichev, handed one of his veteran crews a special assignment. The crew of the tank 'Guardia' was commanded by Lt. A. Dodunov, and its radio operator, A. P. Marchenko, had been a resident of the city before the war. Fomichev gave them a red flag, and told them to plant it on the roof of the *ratush* (city council hall) at the first opportunity. During the subsequent fighting the crew managed to do so, though Marchenko was wounded in the process. Dodunov's crew knocked out five German tanks during the fighting inside Lvov, but 'Guardia' was hit in a duel with a Panther and Dodunov was killed. He was post-



A pair of T-34/85s of the Polish 2 *batalion motocyklowego, 1 korpus pancernego* stop for refuelling during the drive into Czechoslovakia in 1945. The tanks carry the white Polish eagle insignia besides their tactical number markings. The trucks in the foreground are a Lend-Lease Studebaker US6 2½-tonner, and a captured Magirus.



A T-34/85 of the 36th Tank Brigade, 11th Tank Corps, bed-decked with bedsprings, is parked near the Brandenburg Gate following the surrender of Berlin in May 1945. The bed-springs were welded on during the street-fighting to act as improvised Panzerfaust protection.

humously decorated with the GSS.

As the summer offensive petered out in August 1944 on the banks of the River Vistula in Poland, a series of hard-fought tank battles ensued. Several re-equipped Panzer units were thrown into the fray, including some with the latest *Königstiger* heavy tanks. The first combat experience of the *Königstiger* in the East was not to be a pleasant one.

On the evening of 11 August, Jr. Lt. Aleksander Oskin was ordered to report to 53rd Guards Tank Brigade's headquarters. He was briefed and sent out on a scouting patrol to the small village of Ogledow, where the brigade commander, Col. S. Arkhipov, believed his 2nd Battalion to be. Besides his own crew of four men in the T-34/85, Oskin was assigned the same group of tank in-



IS-2s and T-34/85s of the 9th Tank Corps pour over the Spree River bridge into Berlin, May 1945. On the roadside are a number of derelict ISU-152, ZIS-2 anti-tank guns and a pair of T-34/85s of the 95th Tank Brigade. Tank number 183 shows the white turret bands and roof cross adopted in April 1945 to act as air identification for Soviet tanks. (Sovfoto)

fantry which had ridden on his tank through the Byelorussian and Polish campaigns. On approaching the village, it was obvious that the 2nd Battalion was nowhere to be seen, and the far end of the village was swarming with Germans. Before the Germans could open fire Oskin pulled his tank back, moving some way down the road past a deep ravine and into a large field of ripe corn. He radioed his findings back to Brigade, and was told to remain and watch the activities of the Germans. The hull was already awash in standing corn, so Oskin got the idea of covering the rest with corn stalks. The tank infantry clambered off and complied, also building a couple more large heaps of corn so that the ruse would not be too transparent. Before sunset a German tank column had entered the village and shot it up, but advanced no further before encamping for the night.

The unit in the village was sPzAbt 501, the first German tank unit in the East with the Royal Tiger

heavy tank. Early the next morning, a column of *Königstigers* with infantry riding on them rolled out of the village along the road towards Oskin's tank. The Germans showed no sign of noticing the camouflaged T-34/85, and continued on their way. The gun crew in Oskin's tank could not make out if they were Tiger Is or Panthers, but Oskin remembered a report by the brigade's intelligence officer about new German heavy tanks, and so decided to wait until the tanks were very close before firing. Oskin ordered 'Sub-calibre', and the loader, A. Khalyshev, rammed home a BR-365P high-velocity tungsten core AP round into the breech. The Tigers had closed to about 200 metres and were broadside on when Oskin gave the order to fire. The gunner, Merkhaygarov, slammed the firing pedal, and while the round seemed to hit the second vehicle squarely, there was no visible effect. In seconds, another round struck home, also without apparent effect. The third hit the turret side and the vehicle shuddered. Oskin shouted to Khalyshev, 'Sub-calibre—hit the fuel tank.' The fourth round hit the side of the engine area, and smoke quickly enveloped the vehicle. By now the lead *Königstiger* was swinging



its awkward turret, seeking out its tormentor. The T-34/85 pumped three rounds harmlessly off the front armour, but just moments before the German tank was able to take aim, the fourth round penetrated the turret ring, and flames sprouted out. The third tank was blinded by the smoke from the second, and began backing off across the field at top speed. Oskin detonated the MDSH smoke canisters on the rear of the T-34/85 to give himself cover, and set off after the last *Königstiger*. He closed the range somewhat, and knocked out the last tank with a single shot through the thinner rear armour. On returning to the road, he saw that the first *Königstiger* had stopped burning after a very short time, so Oskin ordered the gun crew to hit it with their last round of high-velocity AP. Two of the tanks soon exploded from internal ammunition fires, and their enormous turrets went toppling through the air like carelessly tossed frying pans. A few prisoners were taken, and Oskin set out for brigade headquarters to report his find. He was subsequently decorated with the GSS for his cool-headed performance in this episode. The *Königstiger* apparently had serious mechanical shortcomings at this stage of the war,

as on Gen. Koniev's front alone the Red Army captured more than fifteen more or less intact. Several were sent back to Moscow for study, while the remainder were used during the summer by T-34/85 and IS-2 crews to try out methods to defeat its thick armour. The T-34/85 had problems except on the sides of the hull and rear, while the IS-2 disposed of it more easily.

Besides service with Soviet troops in World War II, the T-34 equipped the armoured formations of allied Polish, Czechoslovak and Yugoslav units. It equipped both the Czechoslovak *1.cs tankova brigada v SSSR* and the Yugoslav *2-a tankovska brigada*. The Poles initially had a single tank regiment, but by the war's end they fielded a tank corps, two independent tank brigades and numerous supporting armoured formations.

The T-34s of the Polish *1 pulk czolgow* (1st Tank Regiment) entered combat at Lenino in the summer of 1943. The regiment was reformed as a brigade in the summer of 1944 with 71 T-34 Model 42s, Model 43s and T-34/85s as well as fourteen light T-70s, and was sent to the Magnuszew-Warka bridgehead south of Warsaw in August 1944. The bridgehead was a narrow



A pair of T-34 Model 43s drive into Leipzig following the German surrender, to take over the city from the US Army. The vehicle in the foreground is in fact a PT-34 equipped with mounting lugs for a mine-roller attachment. (US Army)

corridor on the left bank of the Vistula held by Soviet infantry, and had come under repeated attack by armour of the 19th Panzer Division and the 'Hermann Göring' Panzer Division. The brigade was ferried across the Vistula, and on 10 August began operations with Soviet infantry regiments in the area. The 'Hermann Göring' was the most immediate threat, and had made serious inroads into the bridgehead around the Studzianki folwark (manorial farm). The brigade fought a series of sharp engagements with Panthers and PzKpfw IVs, and eventually succeeded in pushing the Germans out of the folwark. By 16 August the bridgehead had been secured, and further Soviet reinforcements were poured in. The brigade's losses had been heavy, amounting to 26 tanks, of which eleven were damaged and later repaired, and fifteen were burned out and were total losses. The Germans had left behind twenty armoured vehicles (not counting Hanomag SdKfz 251s) which the brigade records claim were two Tigers, twelve 'T-4s' and six 'Ferdinands'. Like the Russians, the Poles called the PzKpfw IV 'T-4', and also had a habit of calling any of the large German self-propelled guns 'Ferdinands'. In fact,

from examining photos of the battlefield, one can identify many of the 'T-4s' as Panthers, and the 'Ferdinands' as Hornisse.

By the time that the January offensive of 1945 was unleashed, most Soviet tank corps had been heavily re-equipped with T-34/85s. Some independent tank brigades still had the older T-34 Model 43. By this point in the war entire German Panzer divisions were smaller in strength than Soviet tank brigades, and German tanks were seldom encountered in very large numbers. Some of the heaviest tank-versus-tank actions occurred around Lake Balaton outside the Hungarian capital of Budapest. The Germans still had a few aces up their sleeves, and the 26th Panzer Division had a number of infra-red-equipped Panthers which gave the Russian mechanized corps in the area a very rough time. In a single engagement around Stuhlweissenburg the Red Army lost over 60 tanks, most of them Shermans, in one night. Some German wonder-weapons did not enter action in time to have any effect. The Russians found one Maus superheavy tank at the proving grounds at Kummerdorf, and another guarding the approaches to OKH staff headquarters at Zossen.

Even after the fall of Berlin, heavy fighting continued in Prague. The first Soviet tank to break

into the centre of the city and link up with Czech insurgents was the T-34/85 of Lt. I. G. Goncharenko of the 63rd Guards Tank Brigade (see Plate D2). He was decorated with the GSS for his rôle in the Prague fighting, but was killed later in the city when his tank was hit by an anti-tank gun.

With the conclusion of the war in Europe the Soviet Union began shifting forces eastwards into Manchuria. Hundreds of T-34/85s, mostly of the 6th Guards Tank Army, were employed in the lightning war against the Kwangtung Army in August 1945. The Japanese had marshalled most of their armour for a counter-stroke, but due to Japan's surrender this did not occur and there were no major tank-versus-tank encounters in this theatre. This was just as well, as the outdated Japanese Type 97s and Type 95s would have been near-useless against the T-34/85. Most of the captured Japanese tanks were turned over to Mao Tse-Tung's guerilla forces.

Post-War Service

The T-34/85 again made headlines in the summer of 1950 when the North Korean 1st Tank Brigade spearheaded the invasion of South Korea. The T-34/85s were a major factor in the early successes of the North Koreans, but once the influx of American Shermans and Pershings began, they were contained. The larger portion of them were destroyed by air strikes, and large-scale tank encounters, like those in the 'Bowling Alley', all ended in one-sided victories for the US Army. Following the brigade's destruction, neither the North Koreans nor Chinese made any major use of armour.

In the post-war years the T-34/85 became a staple export item of the Soviet Union to its allies and satellites. Production started in both Poland and Czechoslovakia, and total output of the T-34 series, not counting its self-propelled gun versions, amounted to about 80,000 vehicles. Russian T-34/85s, T-54s and IS-3s fought against insurgent Hungarian T-34/85s in the bloody Hungarian uprising of 1956. That same year, the Egyptian 4th Armoured Division, newly equipped with

T-34/85s purchased from Czechoslovakia, was roughly handled by the Israeli Army in the Sinai. Some of the survivors fought again in 1967. The Syrian Army had also purchased T-34/85s from Czechoslovakia, but the battles on the Golan Heights in 1967 did not involve the prodigious numbers of tanks engaged in the Sinai that year. A number of T-34/85s were knocked out in the heights south of the town of Banias, and these were probably from the Syrian 44th Armoured Brigade stationed in the area. A number of re-manufactured T-34/85Ms were supplied to North Vietnam during its war with the United States. It did not see as much action in the South as did the T-54, T-59 or PT-76, though apparently it was committed in roughly brigade strength to the fighting in Quang Tri province during the 1972



A T-34/85 of the Yugoslav 2-a tankoska brigada stands idle while its crew takes a break in Vinkovci in the spring of 1945. The red star marking on the turret is in the 'bloated' style typical of Yugoslav insignia of the period. (USAF via Dana Bell)

April offensive. There are few reports of these tanks being encountered by either the US Army or the ARVN, and this brigade may have been the column of 35 tanks wiped out along Highway One north of Dong Ha by a single B-52 strike. T-34/85s crewed by Cuban and Angolan soldiers fought in the Angolan civil war; and a handful of Yugoslav-supplied T-34/85s were used by the Greek militia around Famagusta in Cyprus against the Turkish invasion force during Operation 'Attila' in August 1974. The T-34/85 has not been used as a first line tank in the Soviet Army since the 1950s, but it does linger on in the arsenals of many Third World countries.

In its forty years of combat use, the T-34 has proven itself one of the most effective tanks in history. It set the pace for tank design in World War II, and only the M4 Sherman has rivalled it for length of service life and quantity of production. Like the Sherman, its sensibly austere design made it better suited to mass production than the more finely crafted German tanks; and in the end it swamped the emaciated German Panzer divisions in one of the most rapid advances in military history.

T-34/85

BASIC TECHNICAL DETAILS

Crew: 5
 Weight (metric tons): 32
 Dimensions: length—26ft 7in. (815mm)
 width—9ft 8in (300mm)
 height—8ft 9in. (272mm)
 Armour: 0.8in.—3.5in. (20–90mm)
 Engine: V-2-34 diesel, 500hp at 1,800rpm, 12
 cylinder, 4 stroke
 Maximum Road Speed: 34mph (55km/h)
 Road Range: 223.6 miles (360km)
 Terrain Range: 192.6 miles (310km)
 Main Gun: 85mm ZiS S-53 Model 1944
 (L/54.6)
 Supplementary Armament: Co-axial and hull
 7.62mm DTM machine gun
 Ammunition: 85mm, 60 rounds; 7.62mm,
 1,920 rounds

The Plates

A1: *T-34 Model 1941/42 of Jr. Lt. I. T. Lyubushkin GSS (= Hero of the Soviet Union); 4-ya tankovaya brigada, 1-i batal'on; Mtsensk, October 1941*

Lyubushkin's T-34 was one of the STZ-style tanks with a flat rear turret plate and some new 1942 features such as hammerhead tow shackles. This brigade carried no markings at all; the scheme is whitewash crudely applied over factory dark green, the white seldom extending to the suspension or the rear of the hull.



Tank 1-23 of Lt. I. Goncharenko of the 63rd Guards Tank Brigade enters Prague amid cheering crowds on 9 May 1945. This tank was subsequently knocked out in the street-fighting that followed. (Jiri Hornat)

A2: *T-34 Model 1942 of Jr. Lt. A. F. Nayumov GSS; 133-ya tankovaya brigada; Novaya Nadyezhda, Stalingrad area, January 1943*

Nayumov's tank was of the Krasnoye Sormovo Plant type, characterized by extensive handrails and other small fittings. It is uncommon in having both the early style hull panniers and the later box-type fuel containers at the rear. The finish is whitewash over factory green. The large turret marking is 'Tambovskii Kolkhoznik' and below it is the smaller legend 'Rudovskii Rayon' (Rudov region)—presentation markings from the collective farm which subscribed for the brigade's tanks.

A3: *T-34 Model 1941, Finnish 1. Panssaridivisioonan (3./1|Ps.Pr.); Aanislinna, Finland, October 1942*

Like **A1** above, this is an STZ model. It is finished in the dark greyish green typical of Finnish tanks of the period, and bears the Finnish *hakaristi* emblem in black with white shadowing; this also appeared on the turret rear, and the white tank number was repeated on the hull rear, centrally. The Finns modified this capture with new fenders, new turret periscopes and new headlights, like those of a T-28 medium tank.

B1: *T-34 Model 1943 of Lt. Gen. A. G. Kravchenko GSS; 5-i gvardyeiskii tankov'i korpus; Kursk 1943*
Kravchenko's command tank during the Kursk fighting had a two-tone camouflage of factory green patterned with earth-brown patches, as did most of the tanks of his unit. The boxes on the hull side are cartons of extra 76mm ammunition. This tank has the common, factory-installed mixed wheel arrangement characteristic of intermediate production Model 43s.

B2: *T-34 Model 1943 of Sgt. Maria V. Oktyabr'skaya GSS; presentation parade, Sverdlovsk, October 1943*

This T-34, driven by the only woman tank soldier to win the GSS, is in the large presentation markings seen when the vehicle was handed over to her crew by a delegation from the Ordzhonikidzevski area. The slogan '*Boevaya Podruga*' is repeated twice; the hull marking, and perhaps both markings, were probably removed when the tank entered combat.

B3: *T-34 Model 1943 of Lt. A. N. Dodunov GSS; 10-i gvardyeiskii tankov'i korpus, 63-ya gv. tankovaya brigada; Lvov, 23 July 1944*

Dodunov's tank was the later production style with the commander's cupola. It is in plain dark green, with the red turret slogan '*Guardia*'—Guard. This brigade did not carry a unit insignia at this date.

C1: *T-34 Model 1943 of Lt. Mateusz Lach; Polish 1 brygada pancerna, 2 pulk czolgow, 1 kompania; Studzianki, August 1944*

Lach's tank was a late production Model 1943 with the commander's cupola. The Poles apparently followed a Russian numbering system: -0 indicated the company commander, and -1, -4 and -7 the platoon commanders. The turret numbers '217' thus identify 2nd regiment, 1st company, 3rd platoon leader. They are followed by the Piast-style Polish national insignia, also in white. This tank was in fact more heavily camouflaged with branches than we show here; a large log is strapped to the left of the hull for an unditching beam. Lach's crew were credited with thirteen kills.

C2: *T-34/85 Model 1944 of Lt. D. G. Frolikov GSS; 2-i gvardyeiskii tankov'i korpus, 4-ya gv. tankovaya brigada; Minsk, 3 July 1944*

The standard factory dark green is relieved by the slogan '*Chervonyets*', the vehicle's unit number, and the corps insignia. The emblem of the 2nd Guards Tank Corps was the white arrow, in this case with a Cyrillic 'L' above it, apparently referring to the initial of the brigade commander's name—in the 4th Brigade, Col. Losik.

C3: *T-34/85 Model 1944 of Lt. I. A. Kisenko; 4-i mekhanizirovann'i korpus, 36-ya gv. tankovaya brigada; Belgrade, May 1945*

Kisenko's tank carries the presentation slogan '*Ot otsa Shulgi—sinu Kisenko*', and the rampant white bear insignia of the 36th Guards Tank Brigade. A large armour patch is evident immediately behind the fuel tank.

D1: *T-34/85 Model 1944 of Lt. Sapunkov GSS; 9-i tankovi korpus, 95-ya tankovaya brigada; before Berlin, April 1945*

Sapunkov's tank carried the markings of the 95-ya tankovaya brigada during the battle for the Seelöwe Heights outside Berlin. During the Berlin fighting the brigade carried the white turret bands and white roof cross used for aerial identification.

T-34/85s of the 6th Guards Tank Army pause in the Chinese sunshine following the lightning war against the Japanese Kwangtung Army in August 1945. Besides the two T-34/85s, there is a Dodge ½-ton truck. (Sovfoto)



D2: *T-34/85 Model 1944 of Lt. I. G. Goncharenko GSS; 10-i gvardyiskii tankov'i korpus, 63-ya gv. tankovaya brigada; Prague, May 1945*

The white insignia was adopted by the 63rd Guards Tank Brigade before the Prague operation; it is marked below the vehicle number '1-23'. This tank has a 55-gallon fuel drum lashed over the regular fuel tank, and an extra ammunition case is carried on the fender.

D3: *T-34/85 Model 1953 of the Syrian 44th Armoured Brigade; Ein Fite, Syria, 10 June 1967*

This tank was finished in a very dark green. The turret roof bears the white aerial recognition ring used by Syria in the 1967 War, and on both turret sides are a red triangle and an Arabic inscription. The vehicle has a large, counter-balanced mount for the DShK heavy anti-aircraft machine gun, and four large stowage bins are fastened to the hull sides.

E1: *T-34/85 Model 1953 of the Egyptian 4th Armoured Division; Cairo, June 1967*

While Egyptian T-34s on parade often carried heraldic insignia like this red horseman, these

A couple of infantrymen from the US 5th Marines look over a pair of T-34/85s of the North Korean 1st Tank Brigade knocked out in fighting around the Naktong River in the summer of 1950. (US Marine Corps)

were not often seen in combat, when a plain, unrelieved coat of dull sand colour was normal. When markings were added, the insignia were sometimes repeated on the hull front immediately below the driver's hatch.

E2: *T-34/85M (rebuilt Model 1944) of the North Vietnamese Army; Quang Tri province, South Vietnam, April 1972*

One of the remanufactured Model 1944s of Zavod No. 183 style supplied to North Vietnam with T-55 style wheels and a new engine. The national insignia in red and yellow is painted well forward on the turret, while the numbers '117' are carried aft. Originally North Vietnamese tanks operating in the South did not carry national insignia, to maintain the pretence that North Vietnamese troops were not engaged in South Vietnam; but by 1972 this charade had been dropped.

E3: *T-34/85 Model 1945 of the Greek Cypriot National Guard; Operation 'Attila', Famagusta, Cyprus, August 1974*

Finished in dark green with earth-brown patches, this tank bears a crudely painted representation of the Greek flag on the turret. The Browning .50 cal. machine gun on a high pedestal mount is characteristic of the Greek T-34s on Cyprus.



F: Interior of hull positions, T-34 Model 1942—see key on page 25.

G: Interior of turret front, T-34/85—see key on page 25.

H: Crew clothing, 1941–45:

Red Army tank crews presented a fairly motley appearance during the war years. At the outbreak of hostilities most seem to have worn a dark brown leather version of the well-known padded crew helmet, and a one-piece overall of either black or dark blue. This was worn over the universal khaki service dress of fly-fronted pullover shirt-tunic, flared breeches, and soft leather knee-boots. NCOs and officers often wore their collar patches of rank and branch on the collars of the overall, and/or visible in its open neck on the fall collar of the shirt-tunic—in the case of officers this latter was piped red. **H1** displays this style, with patches of tank black, piped in the gold of an officer, bearing the brass tank branch badge and the single red-on-brass bar of a captain. We take the very light brown revolver holster and crossbelt from a photo. He holds the dismounted DT hull gun, with infantry bipod.

The overalls were normally manufactured in khaki drab during the period 1942–45, but old black ones occasionally appear in photos. The padded helmet went from leather to black canvas, and occasionally it even appeared in a most unappealing shade of blue. The standard overall design was as worn by **H1**, with concealed fastening, and single left breast and right thigh pockets; but given the vast and dispersed procurement of Soviet clothing during the chaotic war years, many minor variations were seen.

The 1943 uniform regulations changed the appearance of the service dress. The sergeant-major in **H2** wears the simple *pilotka* sidecap worn throughout the war, with the remodelled shirt-tunic of 1943; it has a stand collar, and ranking has moved to the traditional shoulder-boards, here in their field service form of stiff khaki cloth piped red and with red ranking and brass branch badge. Breast pockets were supposed to be exclusive to officers, but we take this figure from a photo. He carries an o-365K High Explosive round for the 85mm gun. Soviet ammunition did



A T-34/85 parades in Luanda, Angola, in February 1976 following the Communist victory. (Sovfoto)

not bear the carefully regulated system of head colours and codings used by the Western allies, and was normally painted either grey or olive green with bare metal driving bands and black or white stencilling.

In cold weather the grey cloth and fleece *ushanka* cap was widely seen; **H3** wears one, with an example of the three-quarter-length leather jacket which began to appear in the mid-war years. It became quite common by the end of the war, and was apparently standard issue in the 1950s. Details seem to have varied. The bulky trousers, insulated versions of the service dress breeches, appear in many photos. He carries a round of UBR-365B Armour Piercing ammunition for the 85mm gun.

The helmet appeared in a longer, fleece-lined version for winter use, and this is seen, with regulation tank crew goggles, in **H4**. This crewman also wears khaki drab overalls, and the khaki quilted winter jacket common to all branches of the Soviet army. Captured German clothing and equipment, such as the belt and Walther automatic worn here, was frequently pressed into service—much of it was superior to Soviet equivalents. The shell is another 85mm AP round, UBR-365.

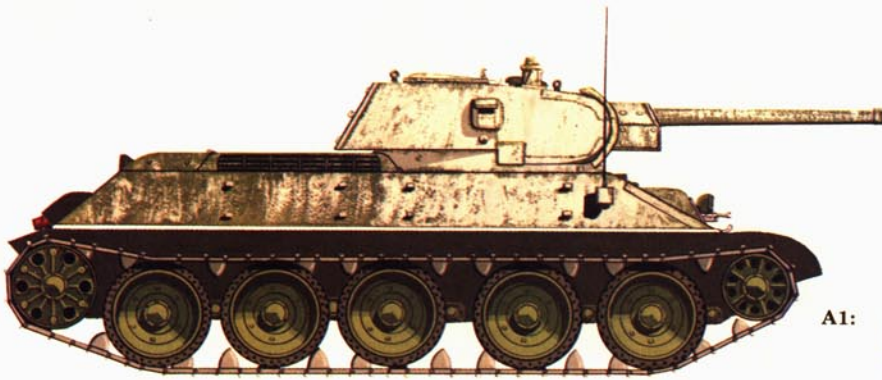

A1: T-34 Model 1941/42 (STZ style)
of Jr. Lt. I. T. Lyubushkin GSS;
4-ya tankovaya brigada, 1 batal'on;
Mtsensk, October 1941

A2: T-34 Model 1942 (Zavod No. 112 style)
of Jr. Lt. A. F. Nayumov GSS;
113-ya tankovaya brigada; Novaya Nadyezhda,
Stalingrad area, January 1943

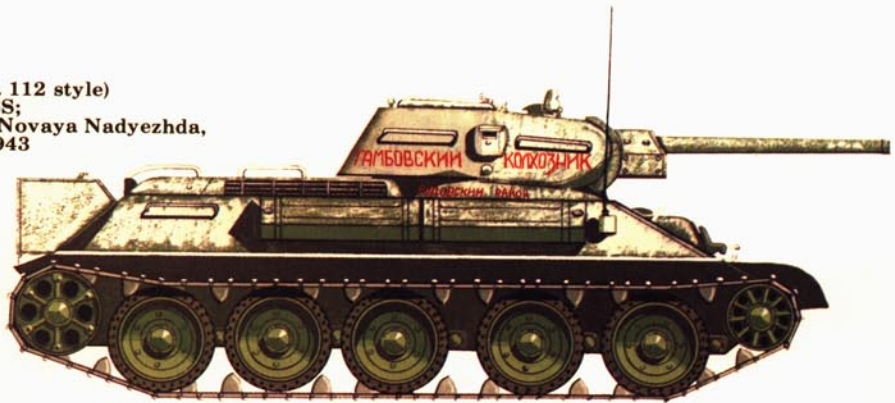

A3: T-34 Model 1941/42 (STZ style)
of Finnish *1 Panssaridivisioonan (3./1/Ps.Pr.)*;
Aanislinna, Finland, October 1942



B1: T-34 Model 1943 (early Zavod No. 183 style)
of Lt.-Gen. A. G. Kravchenko GSS;
5-i gvardyeiskii tankov'i korpus;
Kursk, July 1943

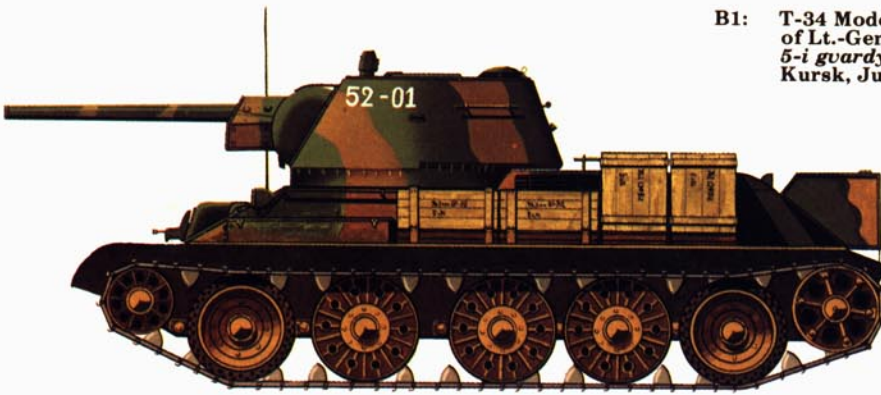

B2: T-34 Model 1943 (early Zavod No. 183 style)
of Sgt. Maria Vasileva Oktyabr'skaya GSS;
presentation parade, Sverdlovsk, October 1943



B3: T-34 Model 1943 (later Zavod No. 183 style)
of Lt. A. N. Dodunov GSS;
10-i gvardyeiskii tankov'i korpus,
63-ya gv. tankovaya brigada;
Lvov, 23 July 1944

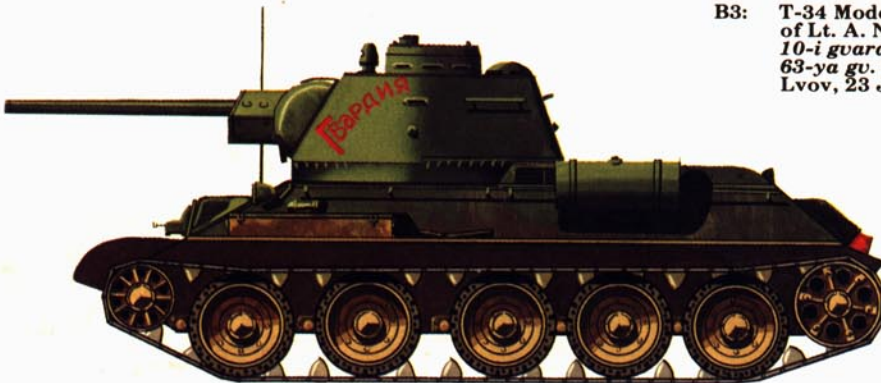



C1: T-34 Model 1943 (later Zavod No. 183 style)
of Lt. Mateusz Lach; Polish
1 brygada pancerna, 2 pułk czotgów, 1 kompania;
Studzianki, August 1944

C2: T-34/85 Model 1944 (Zavod No. 183 style)
of Lt. D. G. Frolikov GSS;
2-i gvardyeiskii tankov'i korpus,
4-ya gv. tankovaya brigada; Minsk, 3 July 1944



C3: T-34/85 Model 1944 (Zavod No. 112 style)
of Lt. I. A. Kisenko;
4-i mekhanizirovann'i korpus,
36-ya gv. tankovaya brigada;
Belgrade, May 1945



D1: T-34/85 Model 1944 (Zavod No. 112 style)
of Lt. B. P. Sapunkov GSS;
9-i tankov'i korpus, 95-ya tankovaya brigada;
before Berlin, April 1945

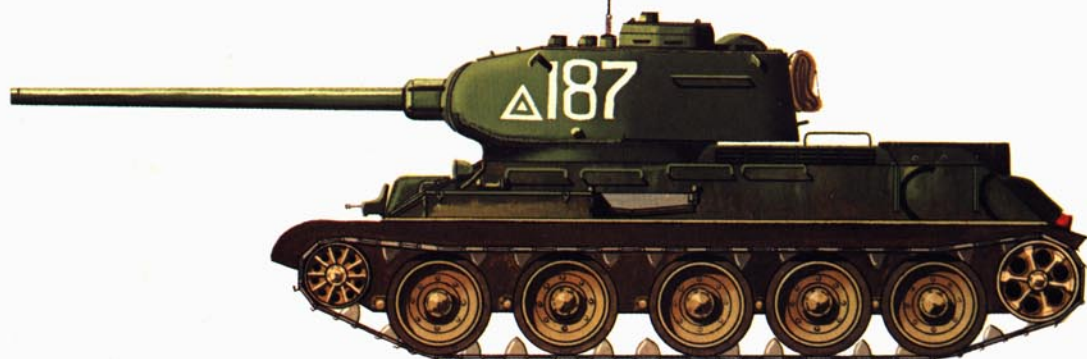

D2: T-34/85 Model 1944 (Zavod No. 174 style)
of Lt. I. G. Goncharenko GSS;
10-i gvardyeiskii tankov'i korpus, 63-ya gv.
tankovaya brigada;
Prague, May 1945



D3: T-34/85 Model 1953 (Czechoslovak production)
of Syrian 44th Armoured Brigade; Ein Fite, Syria, 10 June 1967



E1: T-34/85 Model 1953 (Czechoslovak production)
of Egyptian 4th Armoured Division; Cairo, June 1967

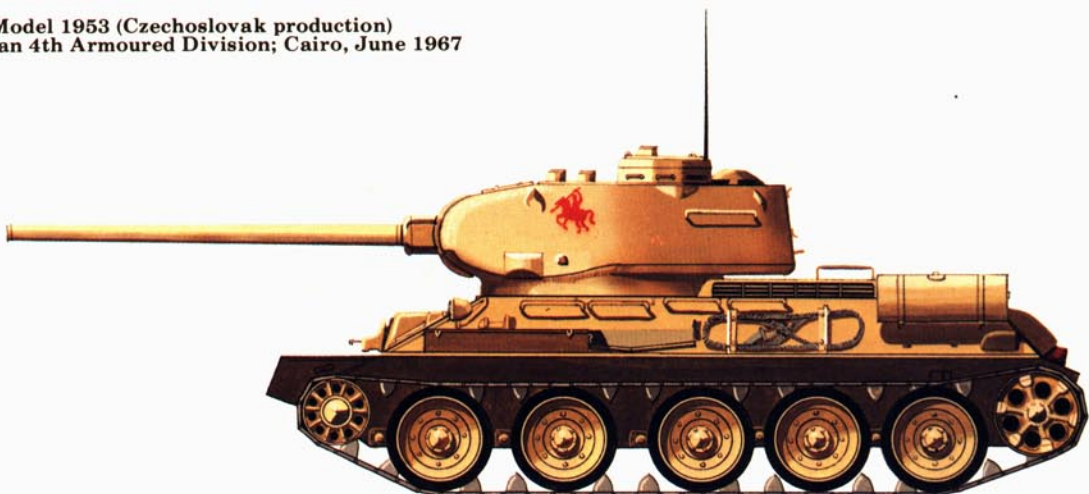

E2: T-34/85M (rebuilt Model 1944, Zavod No. 183)
of North Vietnamese Army;
Quang Tri Province, South Vietnam, April 1972



E3: T-34/85 Model 1945 (Zavod No. 112 style)
of Greek Cypriot National Guard;
Operation 'Attila', Famagusta,
Cyprus, August 1974

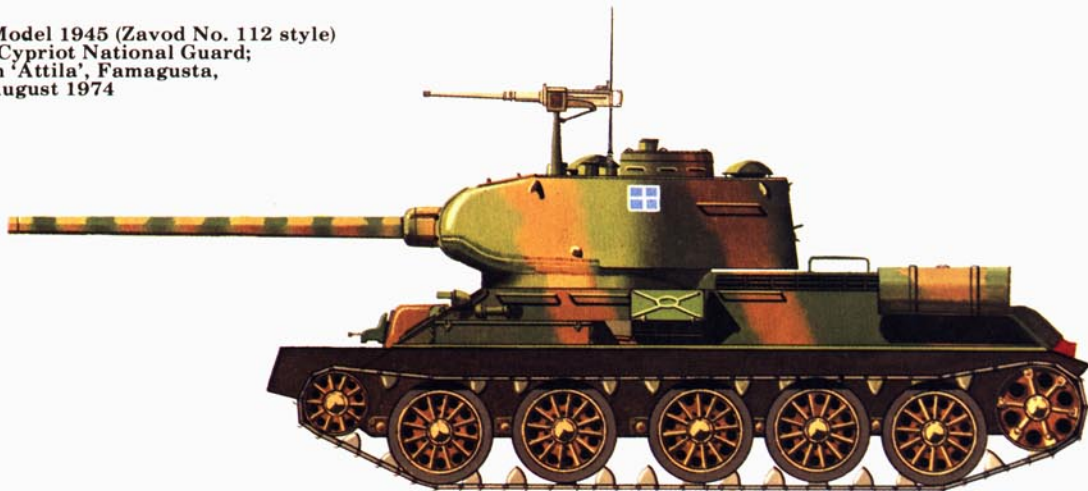

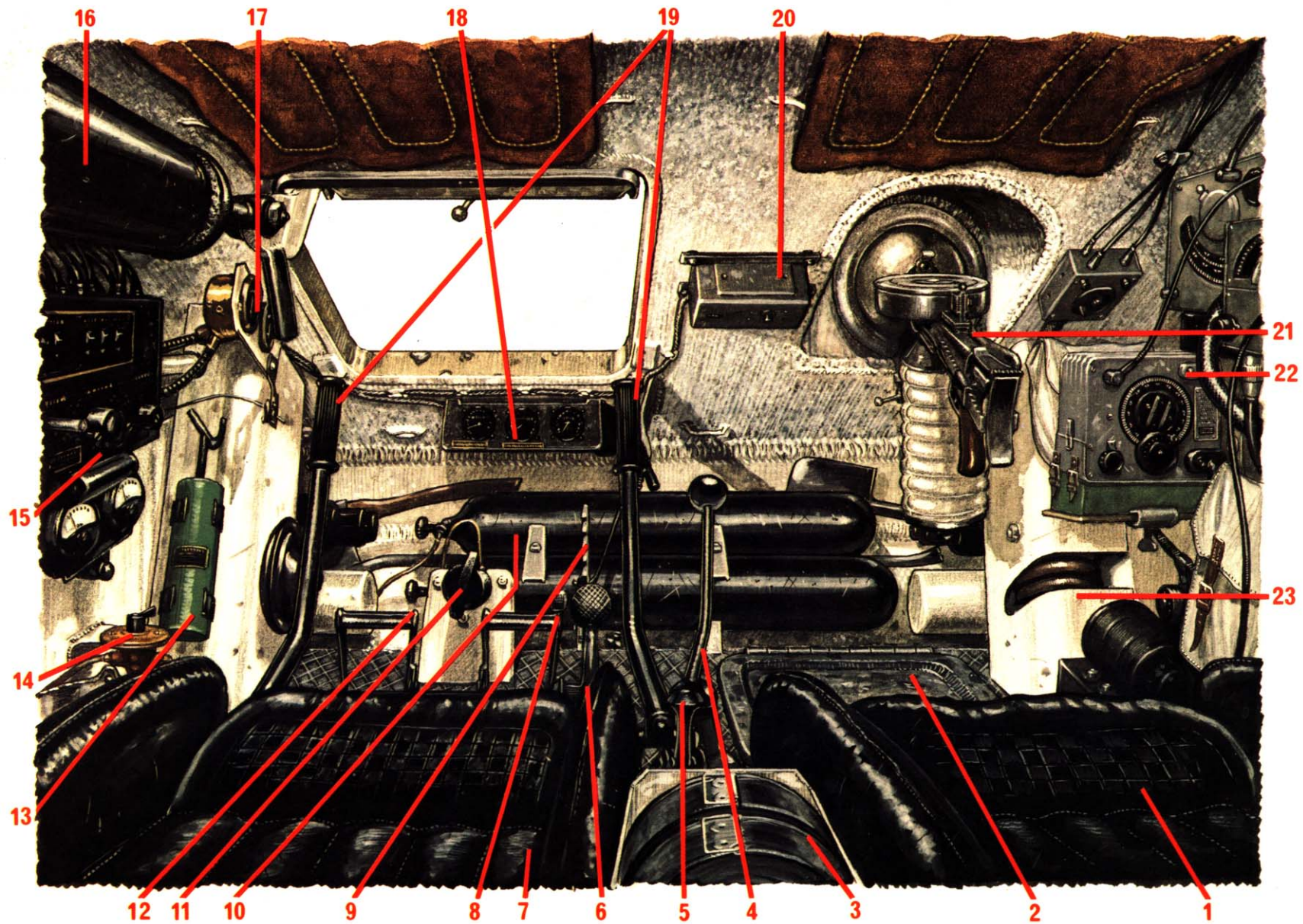

Interior of front hull crew positions, T-34 Model 1942 — see key on page 25

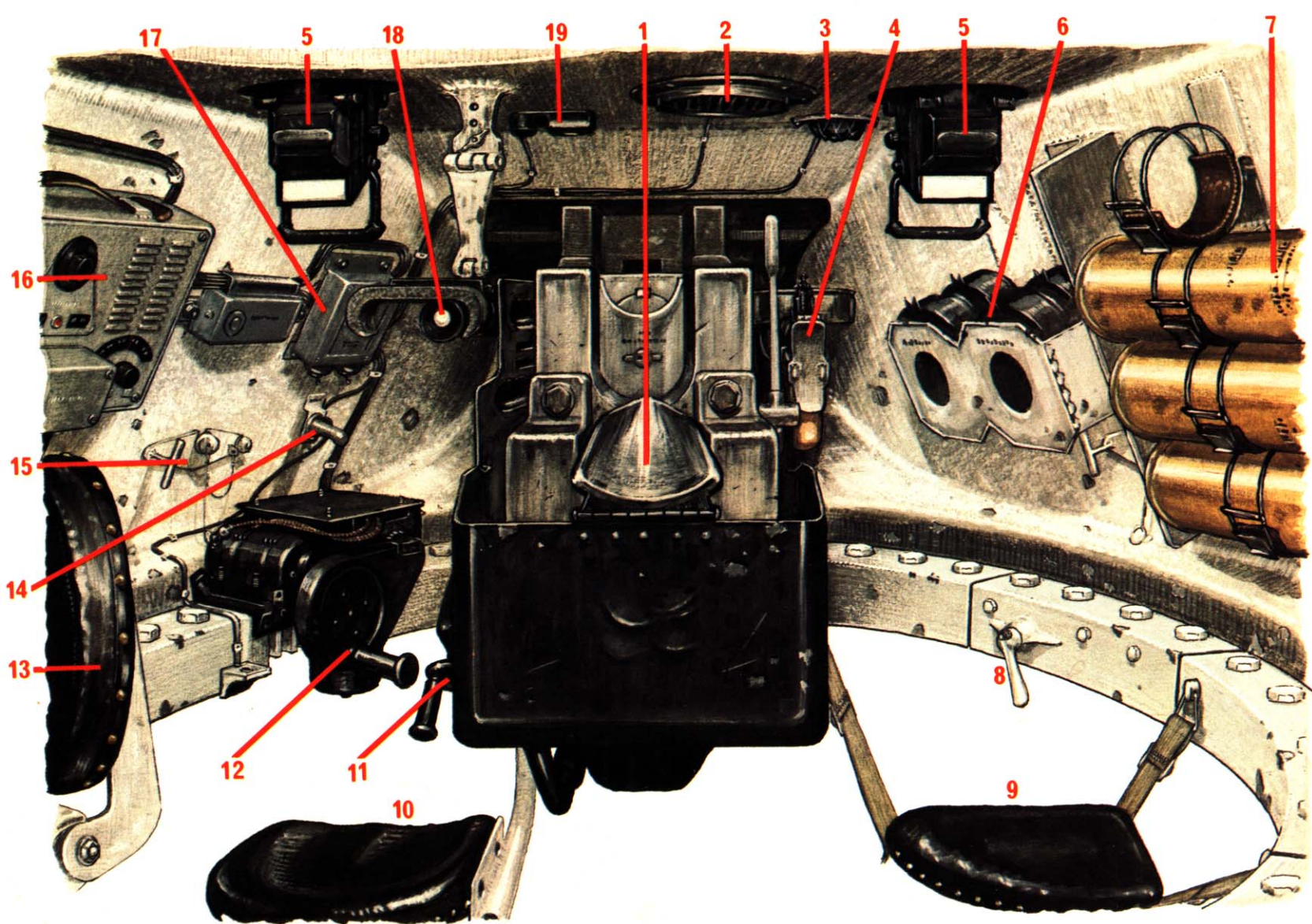

Interior of T-34/85 turret, looking forwards — see key on page 25

Crew clothing, 1942–45:

1. Captain, 1941
2. Sergeant-major, 1943
3. Crewman, 1944–45
4. Crewman, 1944–45

1

2

3

4

